

TCS SERIES ENGINEERING INFORMATION

The TCS-B15B is a low frequency loudspeaker enclosure available in both passive and digitally self-powered formats and designed for use in a wide range of fixed installations.

It consists of a 15" reflex-loaded low frequency driver in an optimally tuned trapezoidal enclosure. The double trapezoidal cabinet is dimensioned to form tight-packed clusters with TCS series 2-way mid/high enclosures equipped with a 15" low frequency driver.

The cabinet is constructed from 15mm (5/8") birch plywood, screwed and glued together for maximum rigidity, with a powder-coated perforated steel mesh grille backed with reticulated foam. Multiple rigging points are provided on the top, bottom, sides and rear of the cabinet to enable it to be suspended in permanent installations using M10 shoulder eyebolts.

A Neutrik® Speakon NL4 speaker connector is located on the rear panel providing input connections, while a 4-way barrier strip provides input and loop-through connections to additional TCS series cabinets.

The TCS-B15B is finished as standard in durable black or white semi-matt textured paint; custom colour options are also available for decor matching. An IP54 weather-resistant version is optionally available (non-powered versions only) with stainless steel grille, weatherproof paint finish and captive cable gland, enabling use outdoors and in humid conditions.

The TCS-B15BDP is a 2 x 800 watt digitally self-powered option featuring a new generation of innovative Class D power amplifier modules, utilising revolutionary 96kHz DSP technology to give operating efficiency in excess of 90%. The fully integrated amplifier and control electronics module incorporates high performance limiters set to optimise the continuous power and excursion thresholds, and is fully networkable to allow remote control and monitoring of critical performance parameters. The switch mode power supply is auto-sensing over a range from 100 volts to 240 volts.



FEATURES

- Compact enclosure**
- Self-powered option**
- Trapezoidal shape**
- Multiple rigging points**
- Custom colour option**
- IP54 weather-resist option**

APPLICATIONS

- Fixed installations**
- Pubs, clubs and bars**
- Music venues**
- Houses of Worship**
- Stadia and arenas**
- Public address**
- Voice alarm**

DIMENSIONS (HxWxD)	838mm x 469mm x 440mm (33" x 18.5" x 17.3")		
NET WEIGHT	TCS-B15B: 37kg (81.4lbs); TCS-B15BDP: 39kg (85.8lbs)		
COMPONENTS	1 x 15" (381mm) LF driver		
FREQUENCY RESPONSE	45Hz - 150Hz \pm 3dB; 30Hz - 200Hz \pm 10dB		
POWER HANDLING	500 watts r.m.s., 1000 watts program		
SENSITIVITY	102dB, 1 watt @ 1 metre (measured in half space)		
MAXIMUM SPL	127dB continuous, 133dB peak		
NOMINAL IMPEDANCE	8 ohms		
CONSTRUCTION	15mm (5/8") birch plywood. Finished in black or optional white semi-matt textured paint.		
GRILLE	Powder-coated perforated steel with foam backing		
CONNECTORS	(1) Neutrik® Speakon NL4MP, wired pin1+: positive, pin 1-: negative, pins 2+ and 2- N/C (1) 4-way barrier strip connector		
AMPLIFIER (TCS-B15BDP)	TYPE:	Class D	
	CONNECTORS:	1 x female XLR (input), 1 x male XLR (link) 2 x RJ45 network, 1 x Powercon mains	
	INDICATORS:	Power (blue), signal (green), limit (red)	
	POWER OUTPUT:	2 x 800 watts continuous @ 8 ohms (1kHz, 0.01% THD)	
	MAX INPUT:	+10dB for rated output	
	BANDWIDTH:	20Hz - 20kHz \pm 0.5dB	
	POWER REQUIREMENTS:	100V to 240V AC @ 50/60Hz, auto switching	
OPTIONS	Optional finishes: white and custom colours. IP54 weather-resistance: stainless steel grille, black or white linex paint finish, captive cable with cable gland (non-powered only)		
FLYING HARDWARE	(8) M10 internal rigging points with internal steel flying strips for M10 eyebolts		
SPARES AND ACCESSORIES	LS1529	LS-1529	15" (381mm) LF loudspeaker
	05B3150	RC-1529	Recone kit
	16F915	TCS-B15XDP AMP	Amplifier module
	07B392	EB-10/18	M10x18mm eyebolt

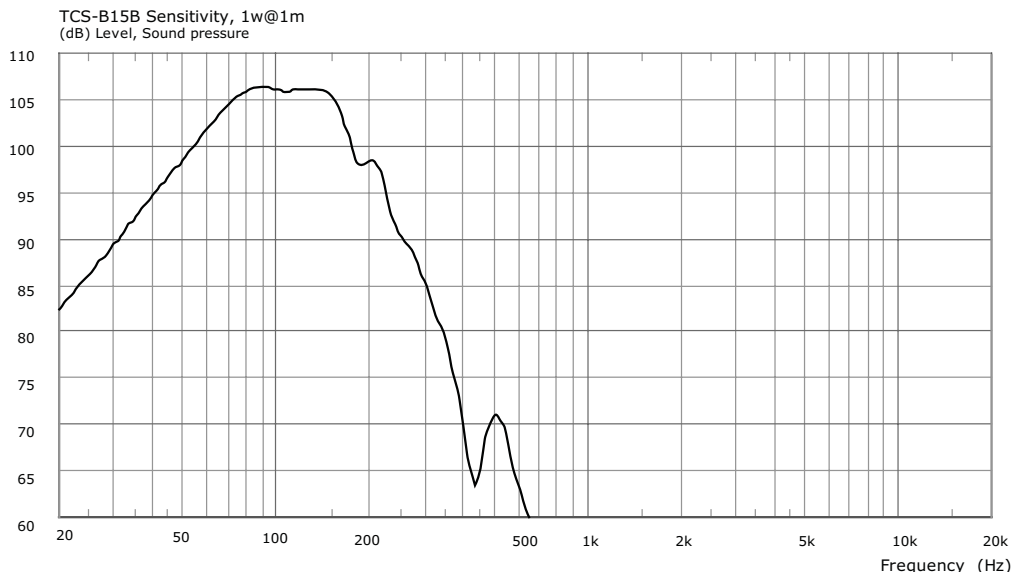

Shown with Turbosound LMS-D2X processor running HPF 24dB BW 20Hz LPF 24dB LR 125Hz. Measured 1w/1m half space 1/3 Octave Smoothed.

**FREQUENCY
RESPONSE**

**NOTES ON
MEASUREMENT
CONDITIONS**

A vertical column of tight-packed bass cabinets together with TCS-152 cabinets can be assembled using ICC-2H, ICC-4H and ICC-5H inter-cabinet couplers, together with FP-1 and FP-2 flyplates.

**INSTALLATION
HARDWARE**

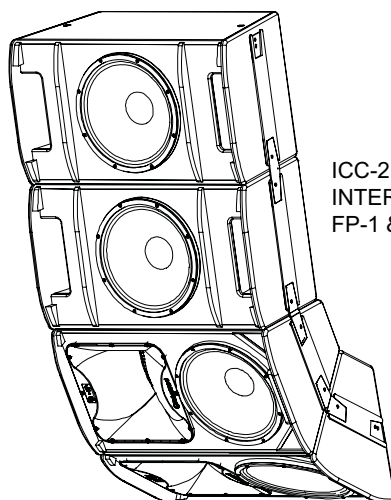

ICC-2H, ICC-4H & ICC-5H
INTER-CABINET COUPLERS
FP-1 & FP-2 FLYPLATES

**ARCHITECTURAL
 & ENGINEER'S
 SPECIFICATIONS**

The loudspeaker shall be of the reflex-loaded low frequency type or optional digitally self-powered type consisting of one 15" (381mm) LF driver. Performance specifications of a typical production unit shall meet or exceed the following: frequency response, measured with swept sine wave input, shall be flat within $\pm 3\text{dB}$ from 45Hz to 150Hz; and within $\pm 10\text{dB}$ from 30Hz to 200Hz. Nominal impedance shall be 8 ohms. Power handling shall be 500 watts r.m.s., 1000 watts program. Sensitivity, measured with 1 watt input at 1 metre distance on axis, mean averaged over stated bandwidth, shall be 102dB. Maximum SPL (peak) measured with music program at stated amplifier input shall be 133dB. Dimensions: 838mm x 469mm x 440mm (33" x 18.5" x 17.3"). Weight: 37kg (81.4lbs) [39kg (85.8lbs) TCS-B15BDP]. The loudspeaker system shall be the Turbosound TCS-B15B [TCS-B15BDP]. No other loudspeaker shall be acceptable unless submitted data from an independent test laboratory verify that the above combined performance / size specifications are equalled or exceeded.

DIMENSIONS

