



RRONYX1640

CASE FOR MACKIE
ONYX I640 MIXER



Rugged Road Ready Features

- * Beefy, Stackable Ball Corners
- * Double Anchor Industrial Rivets
- * Recessed, Industrial Grade Latches
- * Recessed Industrial Grade Handle
- * Industrial Grade Rubber Feet
- * Premium 3/8" Vinyl Laminated Plywood
- * Tongue and Groove Locking Fit
- * Low Profile Base
- * ATA 300 Rating
- * Road Ready Limited Lifetime Warranty

Product Dimensions

Shipping Dimensions (inch): 30.7 x 21 x 11.2

Shipping Weight (lbs): 34.1

Product Dimensions (inch): 30.1 x 20.3 x 10.4

Product Weight (lbs): 31.9

Shipping Dimensions (cm): 78 x 53.5 x 28.5

Shipping Weight (kg): 15.5

Product Dimensions (cm): 76.6 x 51.8 x 26.5

Product Weight (kg): 14.5

Created for the Pro's, the RRONYX1640 is made for the journey and built to hold strong in high stress situations. Designed to fit the Mackie Onyx 1640 mixer in the RRONYX1640 features a heavy-duty removable, latchable cover with our No Pressure Design to protect your mixer controls and our unique low profile base that allows you to access your mixer's rear connection panel without removing the mixer from the case. Tougher than the pavement! That's the idea.

Road Ready Cases

1226 Corral Place * Santa Fe Springs, CA 90670

ph: 562.906.6185 * fax: 562.906.6186

WWW.ROADREADYCASES.COM

RRONYX1640

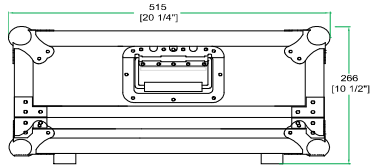

FRONT VIEW

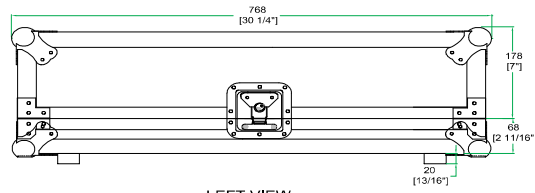

LEFT VIEW

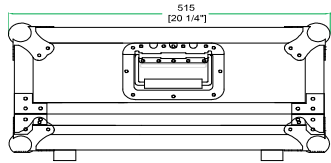

BACK VIEW

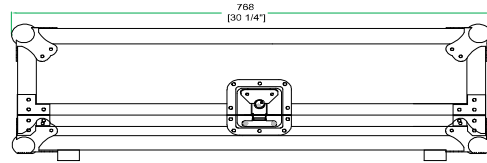

RIGHT VIEW

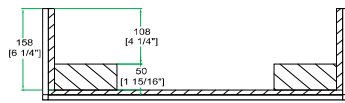

C-C VIEW

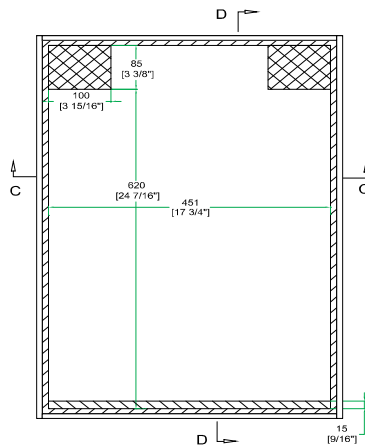

TOP VIEW OF COVER

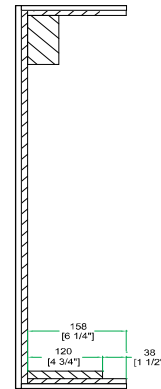

D-D VIEW

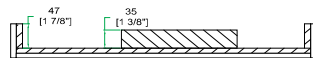

A-A VIEW

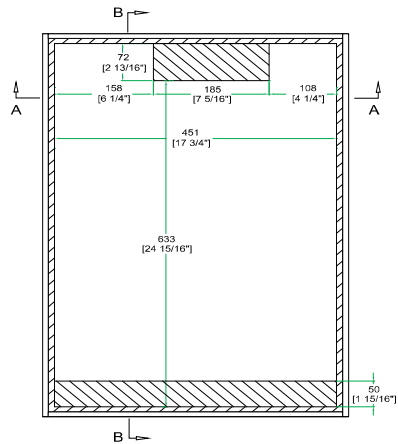

TOP VIEW OF BASE

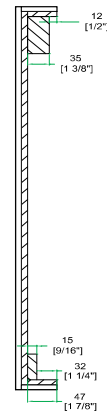

B-B VIEW