



Rugged Road Ready Features

- * Heavy Duty Industrial Grade Ball Corners
- * Double Anchor Industrial Rivets
- * Recessed, Industrial Grade Latches
- * Recessed, Industrial Grade Handles
- * Industrial Grade Rubber Feet
- * Premium 3/8" Vinyl Laminated Plywood
- * Tongue and Groove Locking Fit
- * Low Profile Base
- * Low Profile Wheels
- * ATA 300 Rating
- * Road Ready Limited Lifetime Warranty

Product Dimensions

Shipping Dimensions (inch): 40.5 x 35.2 x 9.8

Shipping Weight (lbs): 65.1

Product Dimensions (inch): 39.8 x 34.5 x 9

Product Weight (lbs): 62.9

Shipping Dimensions (cm): 103 x 89.5 x 25

Shipping Weight (kg): 29.6

Product Dimensions (cm): 101.3 x 87.7 x 23

Product Weight (kg): 28.6

RRM248W

CASE FOR MACKIE SR 24.8
MIXER WITH WHEELS

PICTURE COMING SOON!

Created for the Pro's, the RRM248W mixer case is made for the journey and built to hold strong in high stress situations. Designed to fit the Mackie SR 24.8 mixer, the RRM248W features a heavy-duty, removable, latchable cover for easy access to your gear and our unique low profile base design that allows you to access your mixer's rear connection panel without removing your mixer from the case. And to make transporting your gear even easier we included our low profile wheels for sleek, stealth mobility. Tougher than the pavement! That's the idea.

Road Ready Cases

1226 Corral Place * Santa Fe Springs, CA 90670

ph: 562.906.6185 * fax: 562.906.6186

WWW.ROADREADYCASES.COM

RRM248W

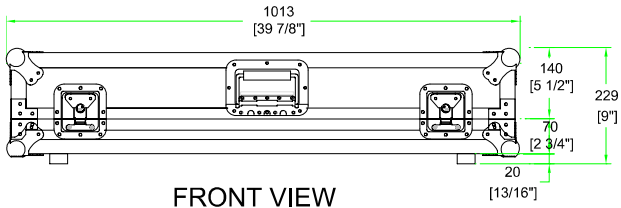

FRONT VIEW

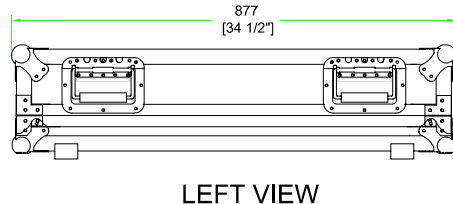

LEFT VIEW

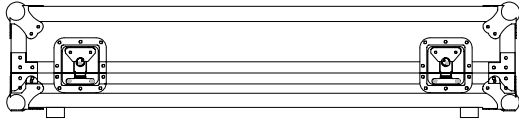

BACK VIEW

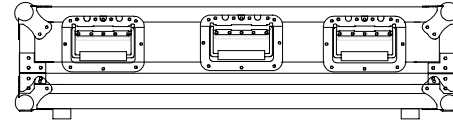

RIGHT VIEW



A-A VIEW

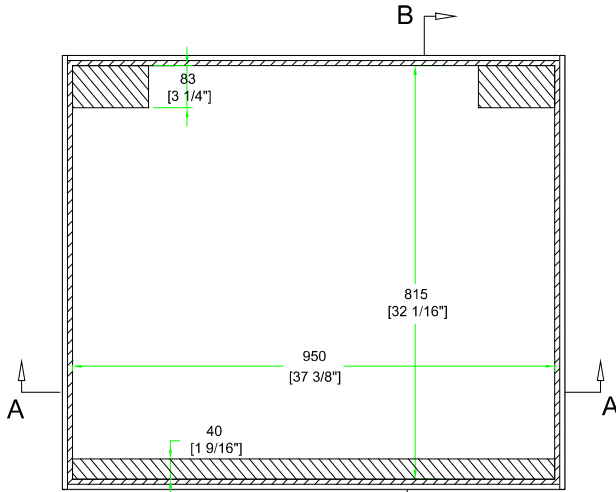

TOP VIEW OF COVER

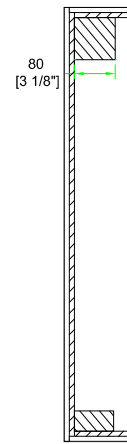

B-B VIEW



C-C VIEW

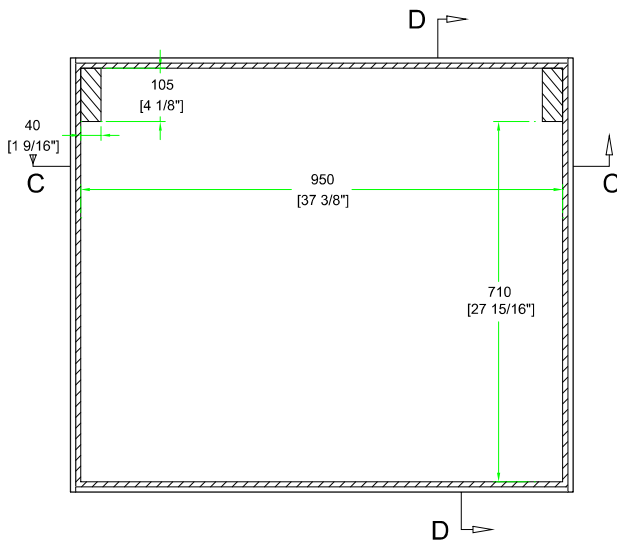

TOP VIEW OF BASE

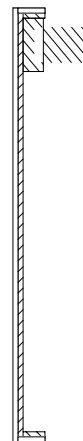

D-D VIEW