



Rugged Road Ready Features

- * Double Anchor Industrial Rivets
- * Recessed, Industrial Grade Latches
- * Industrial Grade Handle
- * Industrial Grade Rubber Feet
- * Premium Vinyl Laminated Plywood
- * Tongue and Groove Locking Fit
- * Low Profile Base Design
- * Road Ready Limited Lifetime Warranty

Product Dimensions

Shipping Dimensions (inch): 17.3 x 19.2 x 6.8

Shipping Weight (lbs): 12.1

Product Dimensions (inch): 16.6 x 18.7 x 6.1

Product Weight (lbs): 11

Shipping Dimensions (cm): 44 x 49 x 17.5

Shipping Weight (kg): 5.5

Product Dimensions (cm): 42.4 x 47.5 x 15.6

Product Weight (kg): 5

RRM14E

MACKIE I202VLZ PRO & I402VLZ
PRO MIXER CASE



More bang for your buck! The RRM14E mixer case is designed to fit the Mackie 1202 and 1402 VLZ Pro mixers. The RRM14E features a heavy-duty removable, latchable cover and adjustable foam lining for the perfect custom fit. We also created the RRM14E with a unique low profile base design that allows you to access the mixer's rear connection panel without removing your mixer from the case. The economical solution!

Road Ready Cases

1226 Corral Place * Santa Fe Springs, CA 90670

ph: 562.906.6185 * fax: 562.906.6186

WWW.ROADREADYCASES.COM

RRM14E

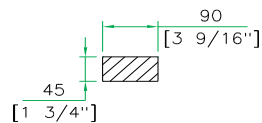
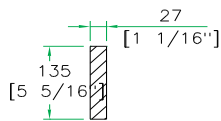
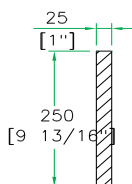
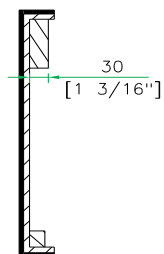
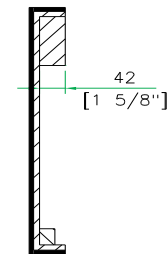
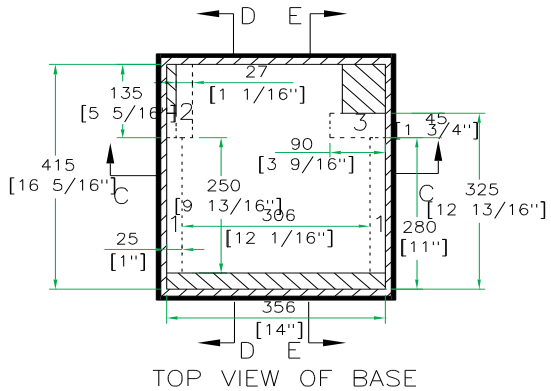
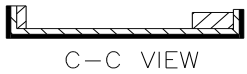
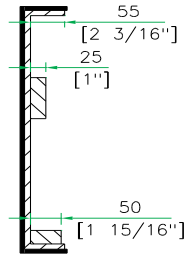
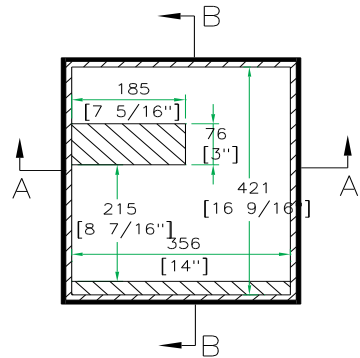
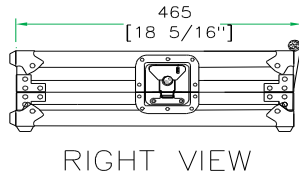
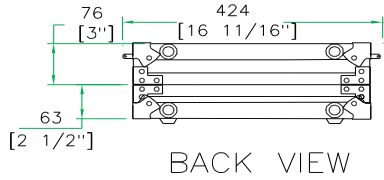
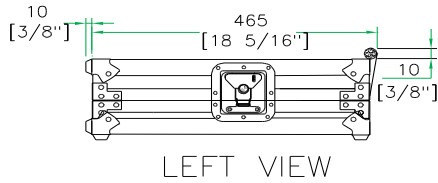
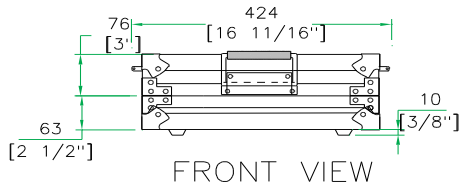

9 13/16"??1"??1 5/8"5/16"??1 1/16"??1 5/8"3/4"??3 9/16"??1 3/16"

FOAM INSERTS FOR MACKIE 1202 VLZPRO MIXER

(PLEASE FOLLOW THE DRAWING TO FIT IN ALL FOAM INSERTS ACCORDING)