



USER MANUAL

MX1800

Electromagnetic and safety compliances

This product complies with the European Electromagnetic Compatibility directives 89/336/EEC & 92/31/EEC and the European Low Voltage Directives 73/23/EEC & 93/68/EEC.

This product is in conformity with the following specifications

NEN-EN 55103-1 Electromagnetic compatibility.
Product family standard for audio, video, audio-visual entertainment lighting control equipment for professional use. Part 1: Emission. (September 1995)

NEN-EN 55103-2 Electromagnetic compatibility.
Product family standard for audio, video, audio-visual entertainment lighting control equipment for professional use. Part 2: Immunity. (September 1995)

following the provisions of Council Directive 89/336/EEC on the approximation of the laws of the Member States relating to electromagnetic compatibility

This product is designed to comply with the following standards:

UL 60950 3rd edition (2000) standard

TUV EN 60950 : 1992+A1+A2+A3+A4+A11 (1997) standard

IMPORTANT SAFETY INSTRUCTIONS

PLEASE READ INSTRUCTIONS BEFORE OPERATING THE EQUIPMENT

- 1) For your own safety, please read the user manual before operating or connecting the unit.
- 2) The user manual must be in possession of the owner of the mixing panel. This manual must be kept on a safe place for future reference.
- 3) The mixing panel must always be connected to a mains power supply net with appropriate grounding. This is necessary for the optimal working of the mixing panel and to assure the safety of the user.
- 4) Always handle the power cord by the plug, do not pull the cord. Do not use broken or damaged power cord or plug. Damaged power cords or plugs can cause fire or create shock hazard.
- 5) Do not open the set; there are no serviceable parts inside. Only qualified service technicians can service inside your set.
- 6) Do not expose to rain or water. Do not spill liquid or insert (metal) objects inside the set. Rain, water or liquid such as cosmetics as well as metal, may cause electric shocks, which can result in fire or shock hazard. If anything gets inside, immediately unplug the power cord.
- 7) If the mixing panel is not used for a longer period (more than one day), please disconnect the power cord from the mains net. Switching off the power switch does not completely turn the mixing panel off.
- 8) **WARNING!** The sound and intensity volume of this product can be very strong and, if not used properly, or if used in too close proximity, can cause temporary or permanent damage to one's hearing, perhaps even deafness. Use with caution and common sense.

INSTALLATION OF THE MIXING PANEL

- 1) The set can be used in every position.
- 2) Do not place the set into direct sunlight, or in a warm moist or dusty place. The operating environment temperature should be between +5°C and +35°C. The relative humidity of the air should be below 85%.
- 3) Always place the unit in a well-ventilated area.
- 4) To avoid disturbances, do not place the set near disturbing equipment, such as transmitters, cell-phones, electro-motors, etc.
- 5) Avoid dust (like ashes from cigarettes) to fall on the mixing panel. Also avoid smoke from (for instance smoke machines or cigarettes) entering the unit. Smoke will accelerate wear on the electronic circuits, potentiometers and faders of the mixing panel.
- 6) Do not place heavy or sharp objects on the mixing panel, these can damage the knobs, switches, LEDs, etc..
- 7) Manipulate the console with care. Avoid abrupt movements of the controls.
- 8) If the mixing panel has to be transported, please use the original packaging or use an appropriately built flight case. Avoid shocks.

CLEANING OF THE MIXING PANEL

- 1) Do not use chemical products or solvents to clean the set. To clean the mixing panel, it is best to use a soft brush or a dry lint-free cloth.
- 2) Do not use contact spray or other products in the faders. The contact spray can damage the faders.

Congratulations with the purchase of a RODEC MX1800 mixing panel!
You are the owner of a top-line mixing panel, capable of outstanding performance in combination with other high-grade systems.

RODEC mixing panels have a well established reputation for high quality, robustly built, good sounding audio equipment. The RODEC mixers are used in the biggest discotheques worldwide, by the most famous DJ's and in the largest rental companies all over the world.

Now, the new top-line series were designed and built with the same precision and devotion as known for years. The well-known analogue sound is kept, completed with some new digitally controlled features and I/O.

The total setup of the mixing panel is described in this user manual, all connectors and controls are explained on the next pages. Also different application setups are quoted here.

Further information about this mixing panel can be found on our website:
<http://www.rodec.com>

For questions, more information or service of your mixing panel, contact the distributor or service center in your country. We possess a widely branched network of distributors and service centers worldwide. The RODEC distributor list can be found on our website <http://www.rodec.com>

Please always mention serial number, date and place of purchase for all matters concerning service.

MODEL MX1800
SERIAL NUMBER (on the back of the set)

Although this manual is compiled with greatest precision, we do not assume responsibility for inaccuracies. Updates or modifications can be applied without prior notice.

Table of contents

	Page:
Electromagnetic and safety compliances	3
Safety instructions	4
Introduction	5
Table of contents	6
Frontpanel with controls	7
Backpanel with connectors	13
Cable configurations	16
Different audio connectors	16
Different audio cables	16
Operating instructions	19
Subsonic filter	23
Application examples	24
Options	29
USB input/output option	29
Alarm / music mute priority in option	29
Digital optical 60mm channel fader	29
Digital optical 45mm crossfader	30
Standard knobs set MX00 series	30
Fader knobs BX/CX/MX MKIII/MX00 series	30
Specifications	31
Explanatory words list	33

Frontpanel with controls

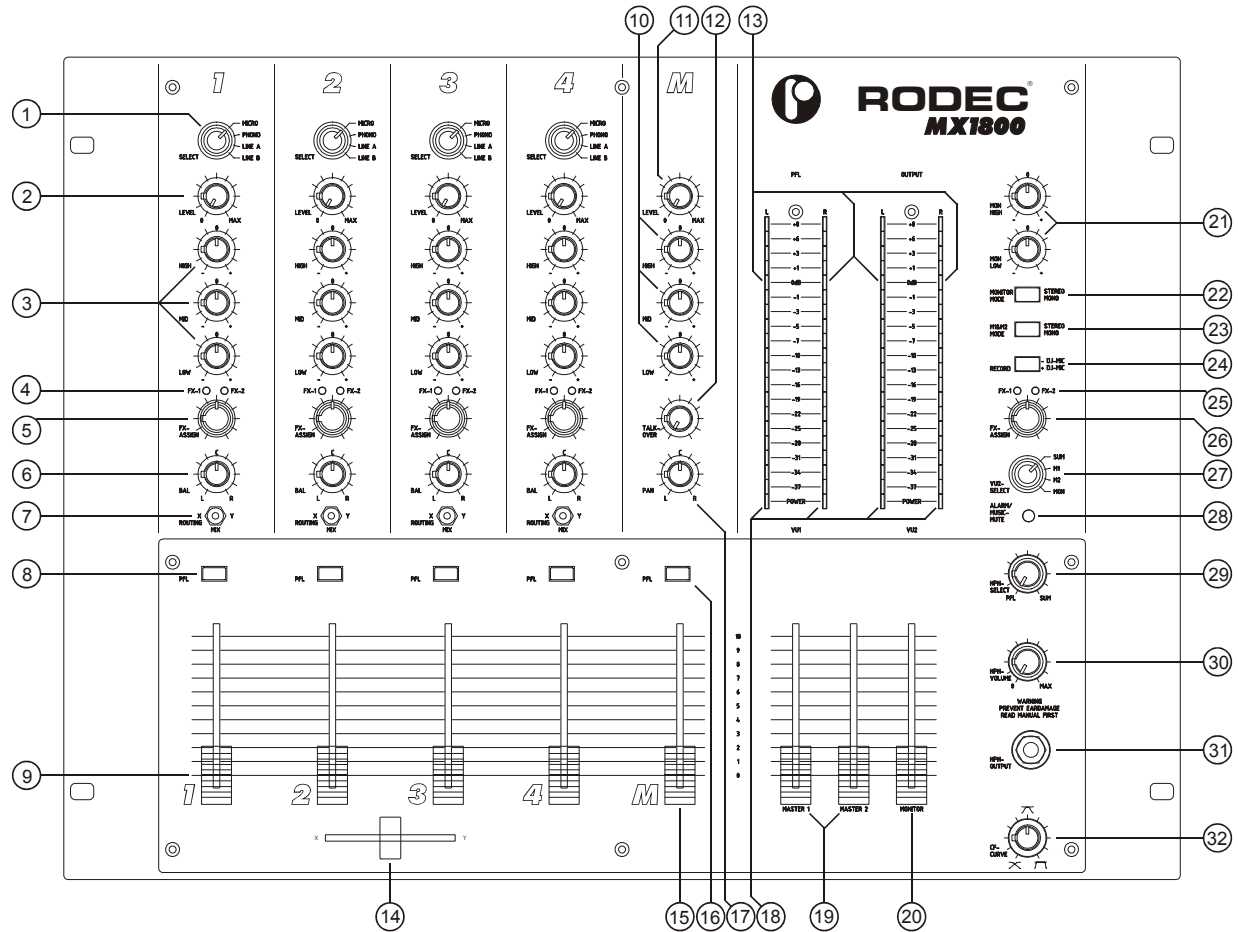

- 1) **Input select switch**
This selector is used to select the input signal: MICRO, PHONO, LINE A or LINE B.
- 2) **Input level potentiometer**
With this control the input level of each input channel can be set.
- 3) **Equalizer controls**
These controls regulate the amount of treble, middle and bass in the sound.

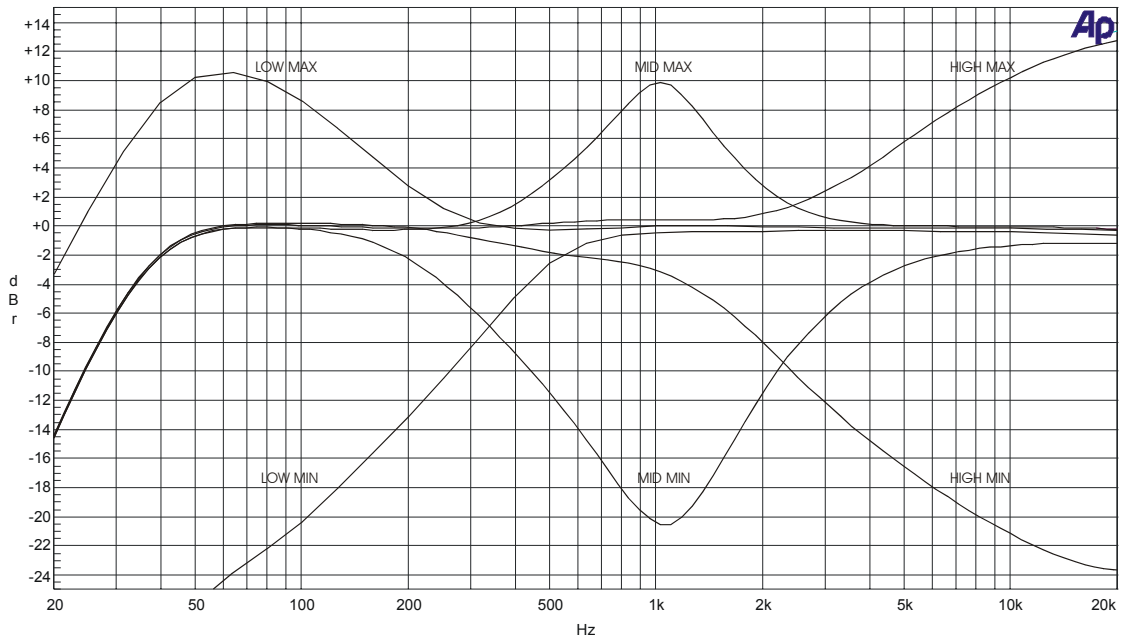

- 4) **Input channel effects assign indication LED's**
 These LED's indicate which channel is routed through one of the effects outputs. If the FX-1 and FX-2 LED's do not light up, no channel is routed via the effects. If the FX-1 LED of a channel lights up green, that channel is routed via effects output 1. If the FX-1 LED of a channel lights up red, one of the other channels is routed via FX-1 and no other channel can be routed via FX-1 at that moment. Same counts for the FX-2 LED that lights up. If the FX-1 LED is blinking red, the input channel effects assign potentiometer (5) must be turned back to its center position because it was initially placed in a fault position.
- 5) **Input channel effects assign potentiometer**
 With this control, the input signal can be routed via effects output 1 or 2. When the knob is placed in the center (12 o'clock) position, the signal goes straight to the main mix without passing via one of the effects-outputs. When the knob is turned to the left, the signal will go via the effects 1 output. When the knob is turned to the right, the signal will go via the effects 2 output. The proportion between the dry (no effect) and wet (100% effect) can be set with the potentiometer.
- 6) **Balance control**
 The balance between the amount of sound on the left and on the right is adjusted by using this knob. When it is set to the center position, the gain is the same for both the left and the right channel. When turned to the left, the right channel will decrease. When turned to the right, the left signal will decrease.
- 7) **Routing selector**
 With this selector the signal can be lead: to the left side of the crossfader (X), directly to the output (MIX) or to the right side of the crossfader (Y).
- 8) **PFL switches**
 With these switches you can select the different input sources that you will listen to with the headphones.

- 9) **Channel faders**
Volume control for every input channel.

- 10) **Equalizer**
Triple tone control for DJ microphone.

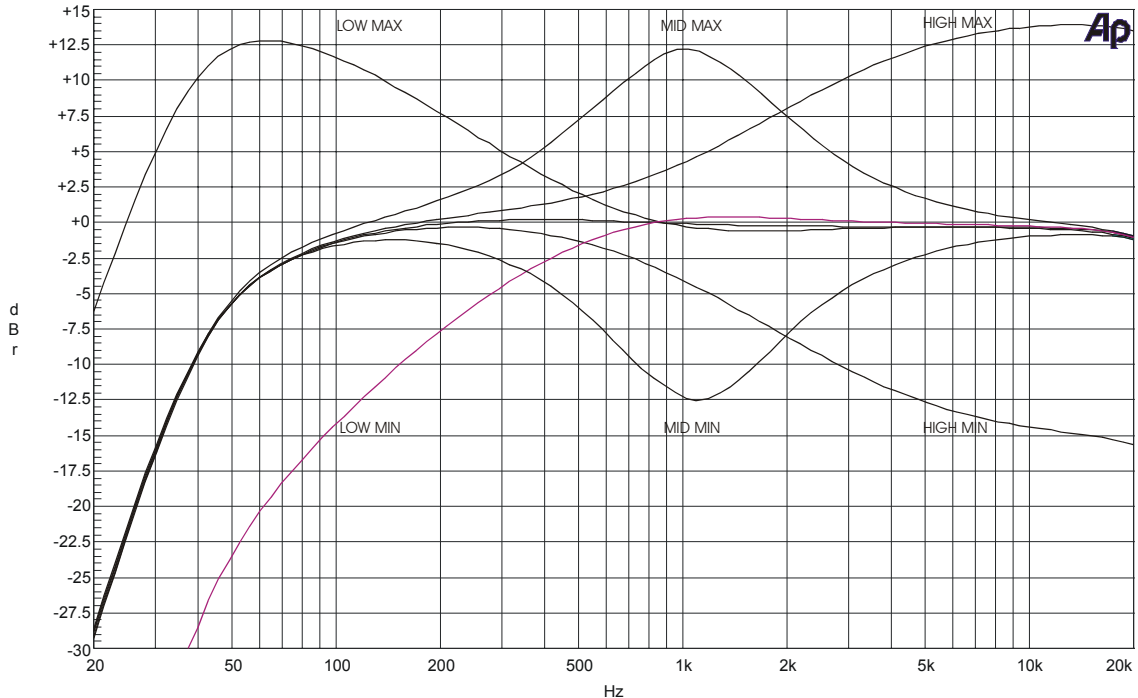

- 11) **DJ microphone input level potentiometer**
Control for accurate level-adjustment of different types of microphones.
- 12) **Talk-over control**
Control for the amount of music suppression controlled by the DJ microphone signal.
- 13) **VU meters**
The two left meters indicate the PFL signal. The right VU-meter displays the output signals, depending on the position of the VU-2 signal select switch (27).
- 14) **Crossfader**
With this fader you can easily fade over between the channels with routing-selector (7) on X-position and the channels with routing-selector (7) on Y-position. When the knob is turned completely to the left, the signal of the channels with routing selector (7) on X will appear on the output. When the knob is turned completely to the right, the signal of the channels with Routing selector (7) on Y will appear on the output. In between there will be a mix of both signals.
- 15) **DJ microphone fader**
Volume control for DJ microphone
- 16) **DJ microphone PFL switch**
With this switch the microphone signal can be made audible in the headphones and made visible on the left VU-meters.

- 17) **Pan Mic**
Panoramic control for DJ microphone input. With this button you can position the microphone signal between the left and right loudspeaker.
- 18) **Power "ON" indicators**
These indicators light up when the power is on.
- 19) **Master 1 and master 2 output fader**
Volume controls final output of mixer towards slave or integrated amplifiers.
- 20) **Monitor output fader**
Volume control for the signal level for the monitor output, this output does not contain the DJ-mic signal to avoid feedback of the microphone-signal via the monitor loudspeakers.
- 21) **Monitor equalizer controls**
Bass and treble adjustment for the monitor output.

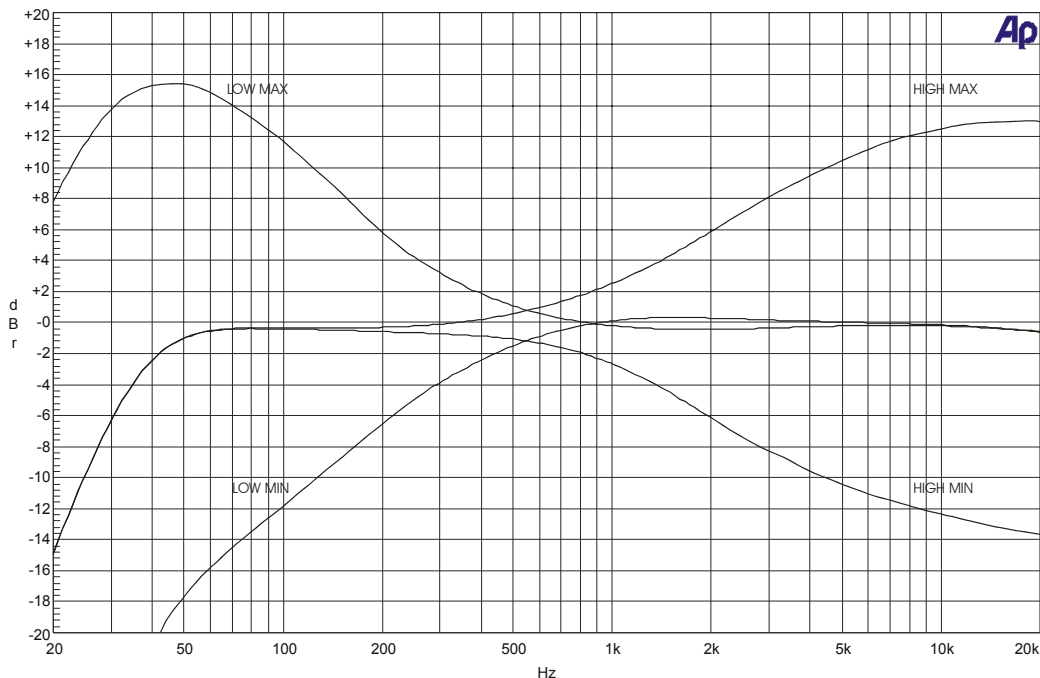

- 22) **Monitor mode Switch**
This switch is used to set the monitor output in mono or stereo mode.
- 23) **Master 1 and master 2 mode Switch**
This switch is used to set the master 1 and 2 outputs in mono or stereo mode.
- 24) **Record Select**
This switch is used to make recordings with or without the DJ microphone.
+ DJ MIC: in this position you add the DJ mic signal to the music.
- DJ MIC: in this position you only record the signal from channel 1 - 4.
This switch has no influence on the master outputs.
- 25) **Main mix effects assign indication LED's**
These LED's indicate if the main mix signal is routed through one of the effects outputs. If the FX-1 and FX-2 LED's do not light up, the main mix signal is not routed via the effects. If the FX-1 LED lights up green, the main mix signal is routed via effects output 1. If the FX-1 LED lights

up red, an input channel's signal is routed via FX-1 output and no other channel can be routed via FX-1 at that moment.

Same counts for the FX-2 LED that lights up. If the FX-1 LED is blinking red, the main mix effects assign potentiometer (26) must be turned back to its center position because it was initially placed in a fault position.

26) **Main mix effects assign potentiometer**

With this control, the main mix signal can be routed through effects output 1 or 2. When the knob is placed in the center (12 o'clock) position, the signal goes straight to the main mix without passing through one of the effects-outputs. When the knob is turned to the left, the signal will go through the effects 1 output. When the knob is turned to the right, the signal will go through the effects 2 output. The proportion between the dry (no effect) and wet (100% effect) can be set with the potentiometer.

27) **VU-2 signal select switch**

With this switch it is possible to select the signal displayed on the two right VU-meters. When the switch is on the SUM position the mix-signal will be displayed. On the positions MASTER 1, MASTER 2 and MONITOR the according output signals will be displayed.

28) **Alarm/music mute indicator LED**

This LED indicates the amount of music suppression due to the control signal on the optional alarm/music mute input. When the LED doesn't light up, the music is not suppressed. When the LED lights up at full power, the music is fully suppressed.

29) **Headphones-select potentiometer**

With this potentiometer, the signal for the headphones output can be selected. When turned completely to the left, the signal selected with the channel PFL-switches (8) appears on the headphones. When turned completely to the right, the mix-signal appears on the headphones. In between it results in a mix of the PFL-signal and the mix-signal.

30) **Headphones volume control**

The volume of the headphones can be adjusted with this knob.

WARNING! The sound and intensity volume of the headphones amplifier can be very strong and, if not used properly, or if used in too close proximity, can cause permanent or temporary damage to one's hearing, perhaps even deafness. Please use with caution and common sense!

31) **Phones output**

Output for high level headphones monitoring. With the PFL switches (8 or 16) and the headphones-select potentiometer (29), the connected audio sources or the main-mix can be made audible without manipulating the output signal (Headphones 32-600Ω).

ATTENTION! Always turn headphones volume to "0" (fully counter clockwise) **BEFORE** putting the headphones on your or somebody else her/his ears! Then slowly raise the volume by turning the volume knob in clockwise direction.

32) **Cross fader curve potentiometer**

This potentiometer is used to set the sharpness of the cross fader. When the potentiometer is turned completely to the left, the cross fader (14) will react as a normal cross fader. The volumes of the channels with routing-selector (7) on Y-position will rise from 0 to maximum when the shaft of the cross fader is moved from the left to the middle. The same counts for the volumes of the channels with routing-selector (7) on X-position, but then from the right side to the middle.

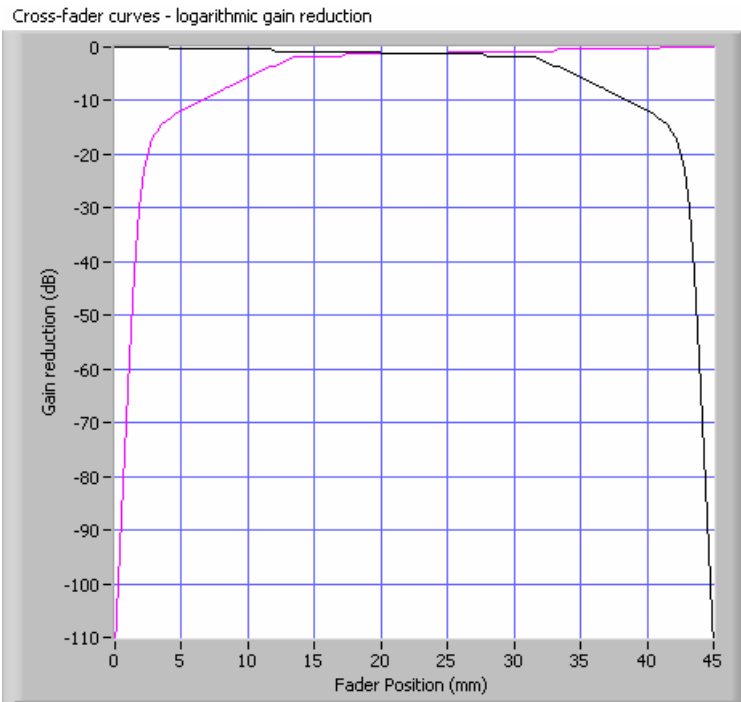

When the curve potentiometer is turned to the right, the cross fader will react very fast, with the volumes of the channels with routing-selector (7) on Y-position rising from 0 to maximum when the shaft of the cross fader is moved from the left to a few fractions from the left. The same counts for the volumes of the channels with routing-selector (7) on X-position, but then from the right side to a few fractions from the right side.

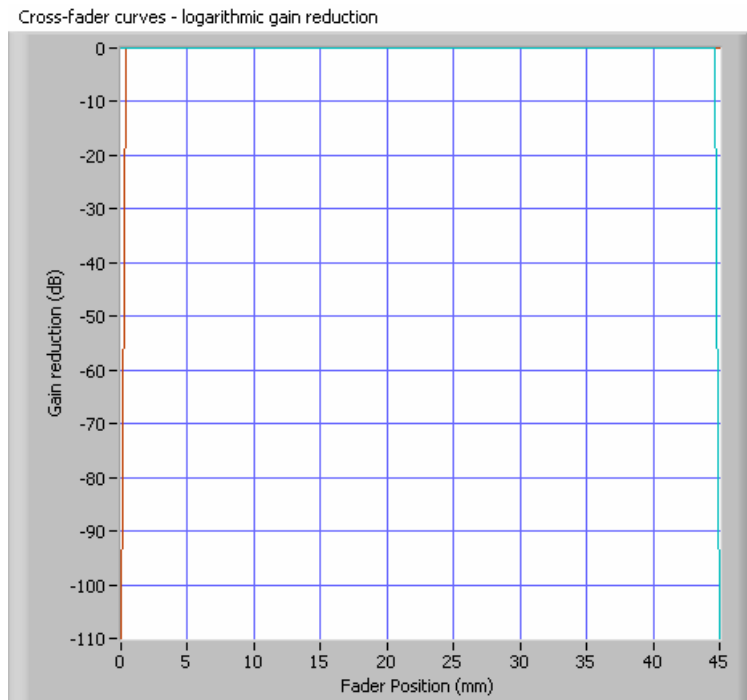

Backpanel with connectors

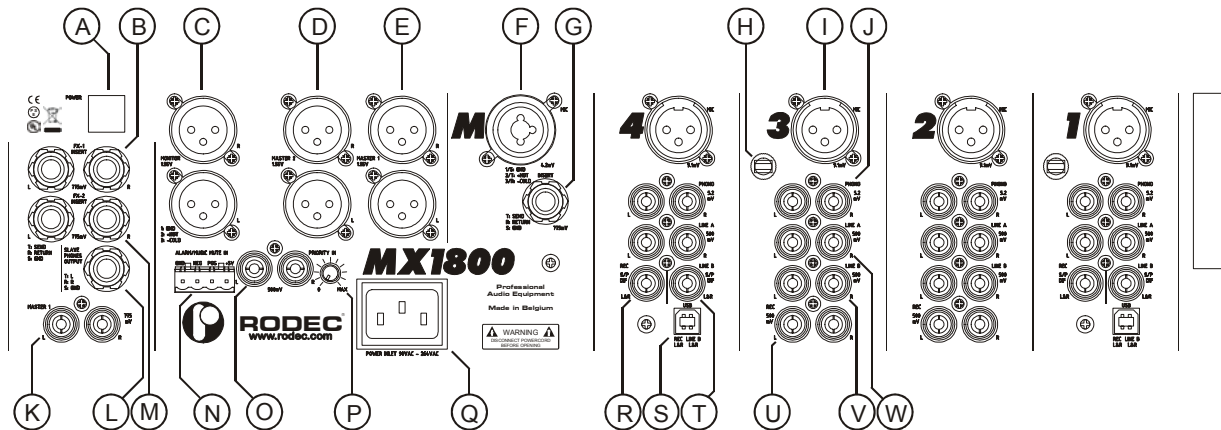

- A) **Power switch**
Controls the supply of AC power to the set. One push turns the mixing panel on, a second push turns it off.
- Attention!** By turning off this switch, the mixing panel is in stand-by mode. At that moment the mixing panel will still consume electricity from the mains net. The power cord has to be unplugged from the power inlet to shut down all power.
- B) **Effects IN/OUT 1**
In- and output to connect effect equipment to the music signal. The signal that runs through this connector is controlled by the input channel effects assign potentiometer (5) or main mix effects assign potentiometer (26). Internally linked when JACK is not inserted. Sensitivity 775mV.
- C) **Symmetrical monitor output**
Additional output up to 1.55V controlled by monitorfader (20). The DJ-microphone signal does not appear on this output.
- D) **Symmetrical master output 2**
Symmetrical output to connect power-amplifier or loudspeaker-processor. The output level can be manipulated with master fader 2 (19) from 0 to maximum (1.55V).
- E) **Symmetrical master output 1**
Symmetrical output to connect a power-amplifier or loudspeaker-processor. The output level can be manipulated with master fader 1 (19) from 0 to maximum (1.55V).
- F) **DJ microphone input**
Balanced microphone input with a sensitivity of 4.2mV, with XLR-JACK combination connector.
- G) **Effects IN/OUT 2**
Input and output to connect effect equipment to the microphone channel. If there is no plug in the JACK connector, the microphone channel works normally, if there is a plug inserted in the JACK, the internal link is interrupted. The sensitivity of this IN/OUT connection is 775mV.
- H) **Ground-terminal**
Terminal to connect the ground wire of the vinyl turntable.

- I) **Micro input**
Balanced microphone input. To obtain good signal quality, you have to use a microphone with balanced output. The use of a microphone without balanced output is also possible.

- J) **PHONO input**
Phono input with a sensitivity of 5.2mV and built in RIAA correction.

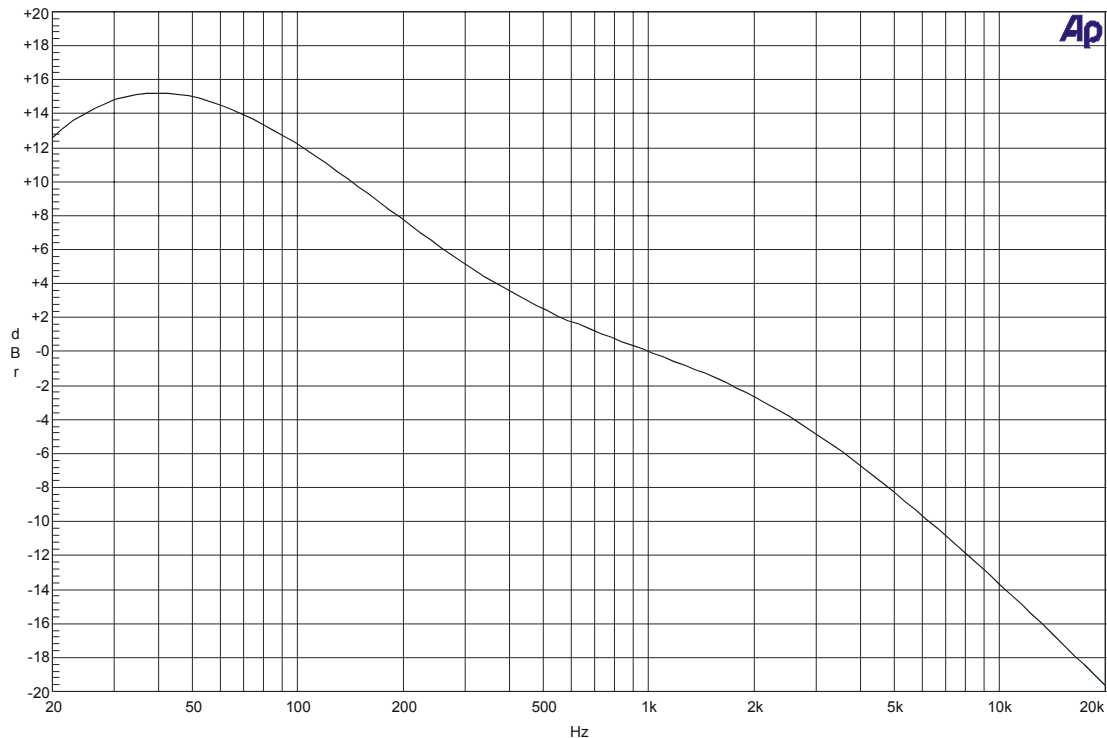

- K) **Asymmetrical master output 1**
Asymmetrical output to connect a power-amplifier. The output level can be manipulated with master fader 1 (19) from 0 to maximum (0.775V).
- L) **Second headphones connector**
Signal identical as headphones-output on the frontpanel (31). The specifications are the same as the headphones output on the frontpanel.
- M) **Effects IN/OUT 2**
In- and output to connect effect equipment to the music signal. The signal that will run through this connector is controlled by the input channel effects assign potentiometer (5) or main mix effects assign potentiometer (26). Internally linked when JACK is not inserted. Sensitivity 775mV.
- N) **Alarm / music mute in connector**
Optional 4-pole connector to mute or turn off the music signal remote controlled. The DJ microphone signal will keep on working normally when the music is muted by the signal on this connector.
- O) **Priority signal input**
Optional input to connect a signal coming from an evacuation-message player, alarm-signal generator, etc. This signal can be played at the moment when the other music signals are muted by the signal on the alarm / music mute connector.

- P) **Priority signal input level potentiometer**
With this control the input level of the priority signal (O) can be set.
- Q) **Power inlet**
Universal mains power inlet.
- R) **Digital recording output**
Output to connect to a S/P DIF input of a MD-recorder, CD-recorder, HD-recorder or DAT-recorder to make recordings. This output can be switched with or without recording the DJ microphone signal (24). Both signals (left and right) go through one connector. (Only provided on channels 1 and 4)
- S) **USB input/output**
Optional USB connector to play music from PC or HD-player and simultaneously record the main mix signal with a PC or HD-recorder. All 4 signals (reproduction left and right and recording left and right) go through one connector. (Only possible on channels 1 and 4)
- T) **Digital line input B**
Digital S/P DIF input, to connect different equipment such as a CD player, MD player, DVD player, MP3-player, HD-player or digital tuner. Both signals (left and right) go through one connector. (Only provided on channels 1 and 4)
- U) **Analogue recording output**
Output to connect analogue recording device or (HIFI) video recorders to make recordings. This output can be switched with or without recording the DJ microphone signal (24). (Only provided on channels 2 and 3)
- V) **Analogue line input B**
Analogue asymmetrical input with a sensitivity of 500mV, to connect different equipment such as a CD player, MD player, DVD player, MP3-player, HD-player, analogue - or digital tuner, cassette player or video player. (Only provided on channels 2 and 3)
- W) **Analogue line input A**
Analogue asymmetrical input with a sensitivity of 500mV, to connect different equipment such as a CD player, MD player, DVD player, MP3-player, HD-player, analogue - or digital tuner, cassette player or video player.

Please use signal cables shorter than 1 meter for the inputs and the outputs.

Cable configurations

a) Different audio connectors

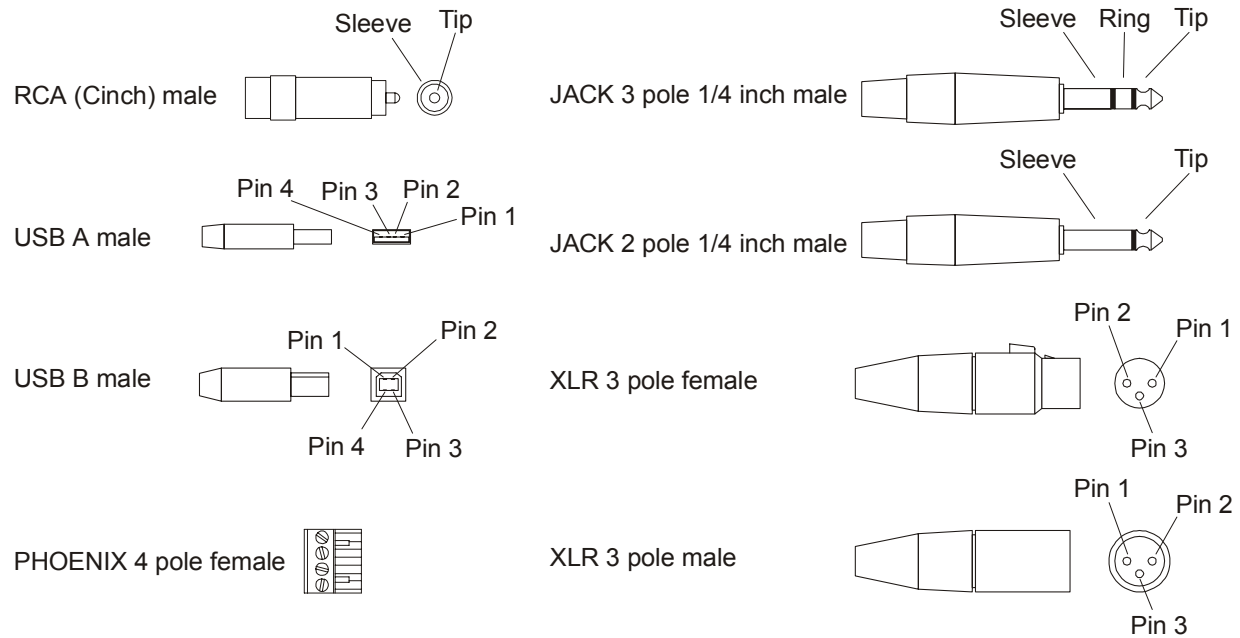

b) Different audio cables

1) Asymmetrical RCA cable:

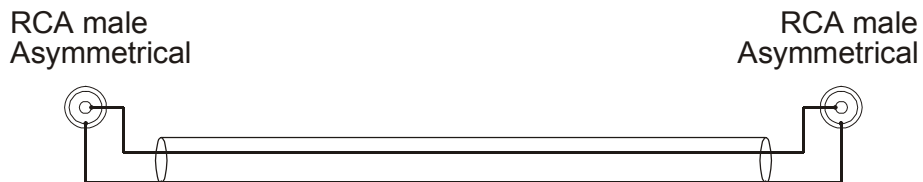

Used for connections between: CD-player, MD-player/recorder, Vinyl turntable, DVD-player/recorder, amplifier, etc. and mixing panel.

For connections of analogue signals, you need 2 of these cables for stereo

For connections of digital S/P DIF, you need only 1 cable for stereo

2) Symmetrical XLR cable:



Used for connections between: microphone, amplifier, equalizer, loudspeaker-processor, limiter, etc. and mixing panel.

For connections of analogue signals, you need 2 of these cables for stereo

3) Symmetrical XLR female to JACK 3pole male cable:

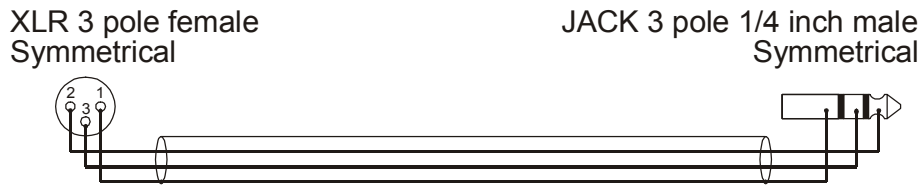

Used for connections between: microphone, amplifier, loudspeaker-processor, etc. and mixing panel.

For stereo connections, you need 2 of these cables

4) Asymmetrical JACK 2 pole male to RCA male cable:

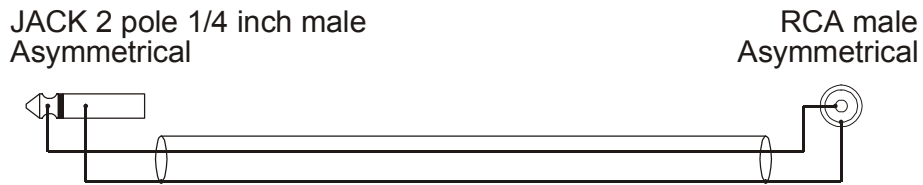

Used for connections between: electronic musical instrument, synthesizer, sampler, effects-machine, amplifier, recorder, etc. and mixing panel.

For stereo connections, you need 2 of these cables

5) Symmetrical XLR female to asymmetrical RCA male cable:



Used for connections between: professional CD-player, professional MD-player, sampler, effects-machine, etc. and mixing panel.

For stereo connections, you need 2 of these cables

6) Asymmetrical RCA male to symmetrical XLR male cable:



Used for connections between: professional recorder, sampler, effects-machine, amplifier, etc. and mixing panel.

For stereo connections, you need 2 of these cables

7) JACK 3 pole 1/4 inch male to 2 times JACK 2 pole 1/4 inch male (Y-split) cable:

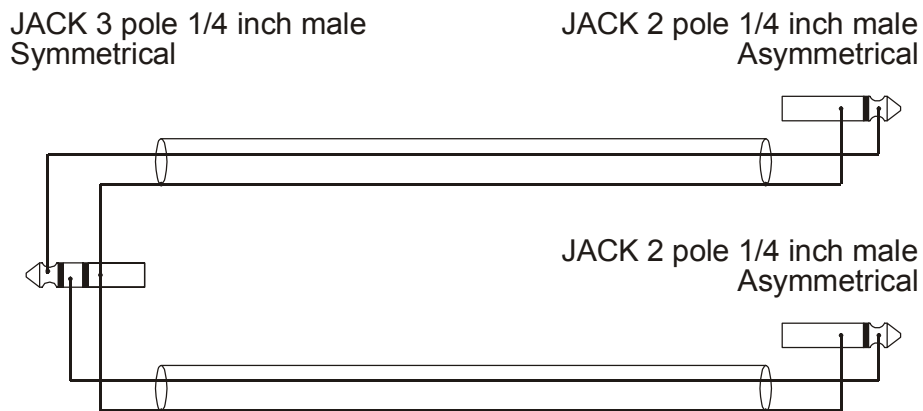

Used for connections between: effects-machine, audio-filter, delay-loop, etc. and mixing panel.
For stereo connections, you need 2 of these cables.
The upper 2 pole JACK is the signal send cable, this has to be connected to the input of the effects-machine.
The lower 2 pole JACK is the signal return cable, this has to be connected to the output of the effects-machine.

8) JACK 3 pole 1/4 inch male to 2 times RCA male (Y-split) cable:

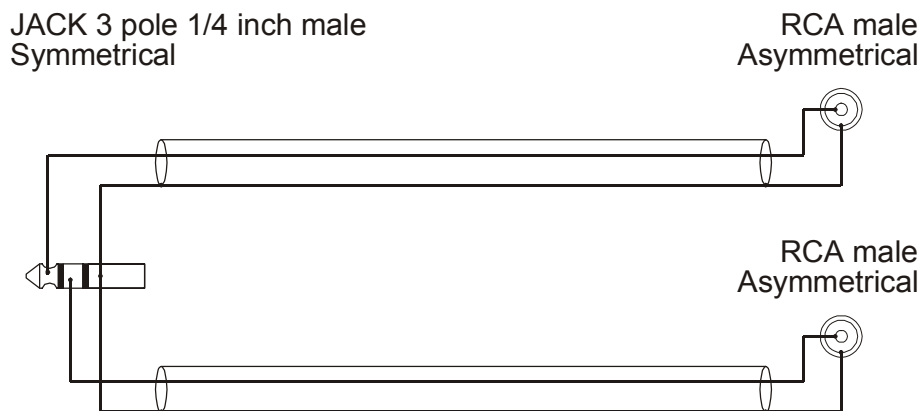

Used for connections between: effects-machine, audio-filter, delay-loop, etc. and mixing panel.
For stereo connections, you need 2 of these cables
The upper RCA is the signal send cable, this has to be connected to the input of the effects-machine.
The lower RCA is the signal return cable, this has to be connected to the output of the effects-machine.

Operating instructions

For correct operation of the mixing panel, please follow the instructions below.

- 1) Before connecting anything to the mixing panel, be sure all equipment is turned off. Then connect the different audio sources, amplifiers, effects-units, headphones, etc.. Next step is to turn on the audio sources and effects-units. When all these units are in ready state, you can switch on the power switch (A) of the mixing panel. The power indicators (18) will light up. After 5 seconds, you can turn on the loudspeaker processors and amplifiers.

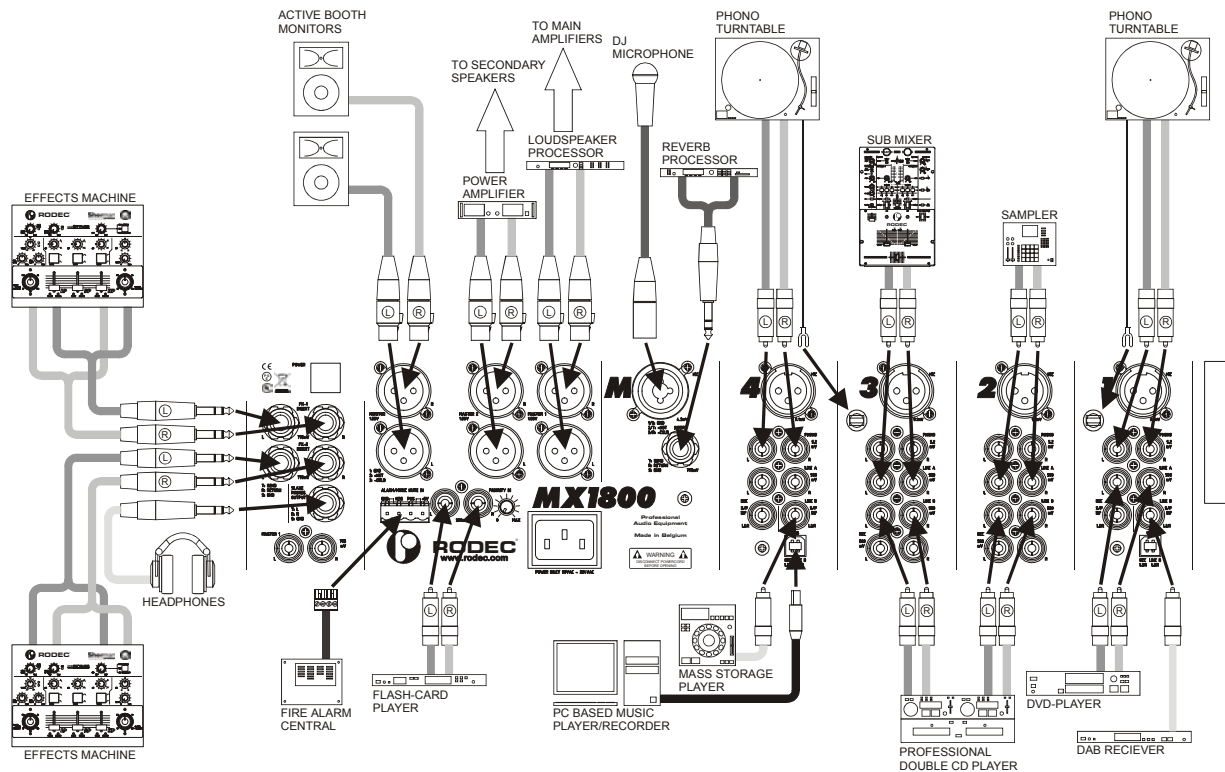

- 2) Connect the headphones to the headphones JACK connector (31) or (L). Use headphones with impedance between 32 and 600Ω.

ATTENTION! Always turn headphones volume to "0" (fully counter clockwise) **BEFORE** putting the headphones on your or somebody else her/his ears! Then slowly raise the volume by turning the volume knob in clockwise direction.

- 3) Choose with the input select switch (1) the right audio-source.
- 4) Switch the PFL button (8) in position ON to listen at the desired source. Turn the phones select button (29) completely to the left and turn the phones volume potentiometer (30) to the desired position to get the stereo signal on the headphones and the two left VU-meters. The PFL circuit works as a sum-system, there is a possibility to listen to more sources at the same time. All these operations have no influence on the output signal! Adjust with the level control (2) the input signal until the red indicators of the level meters (13) will light up occasionally. Adjust if necessary the quality of the sound with the equalizer (3).

LOOK OUT: The equalizer at each input is used to manipulate the sound of each of the input sources. To correct the acoustic of the room it is probably best to use an external equalizer.

- 5) To send the input signal through one of the effects outputs, first check if the desired effects bus is free. This can be done by checking the input channel effects assign indication LED's (4). If the FX-1 LED does not light up, the FX-1 bus is free. If the FX-2 LED does not light up, the FX-2 bus is free. If one of the LED's is blinking red, the input channel effects assign potentiometer (5) is in a wrong position. Then first turn the input channel effects assign potentiometer to its 12 o' clock position, so the LED will stop blinking. To select the FX-1 bus, turn the input channel effects assign potentiometer to the left, first, no effect will be audible, but the influence of the effect will increase when the potentiometer is turned further to the left. When the potentiometer is completely to the left, 100% of the signal will be influenced by the effect. The same procedure can be followed to select FX-2, but then the potentiometer has to be turned to the right. When the FX-1 bus is selected, the according LED will light up green, same for the FX-2 bus. On the other input channels and on the main mix, the according LED will light up red, to indicate the according effects-bus is occupied.

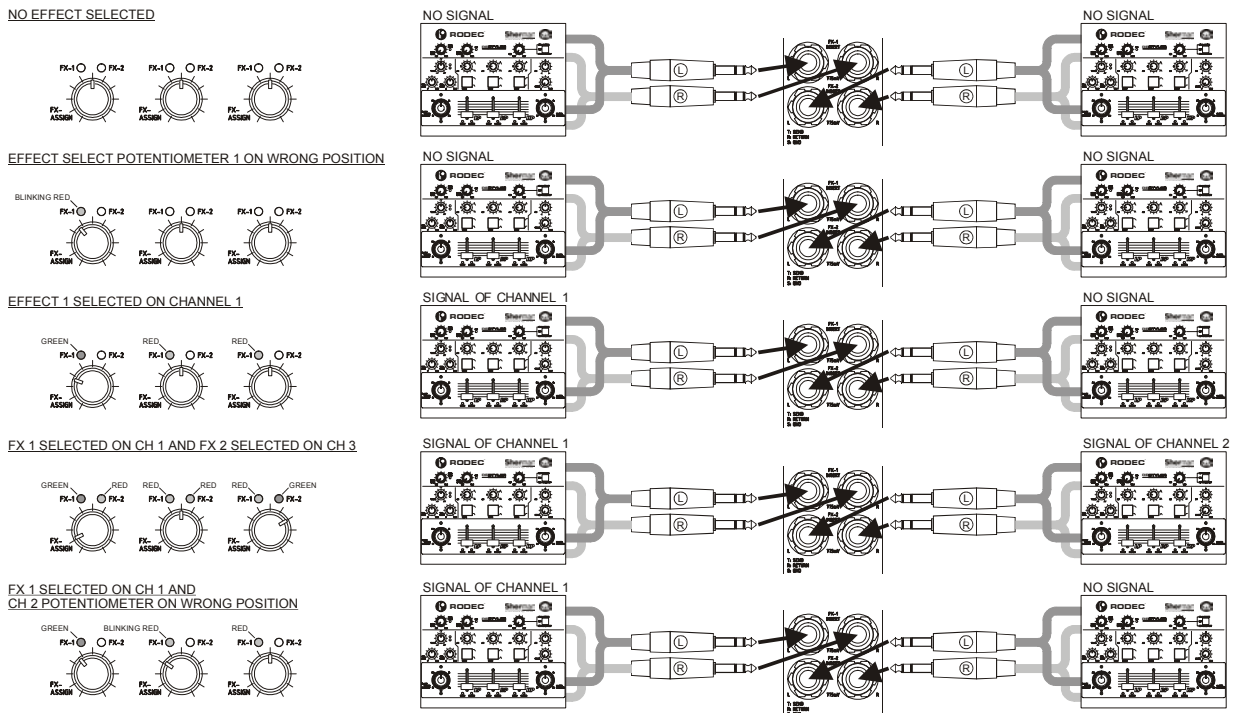

- 6) Open up the fader (9) of the chosen input channel
- 7) Slide up one or both master faders (19) till desired volume is reached. Also open the monitor fader (20), to hear the music at the DJ-booth.
- 8) The music in the DJ-booth can be manipulated with the monitor equalizer (21).
- 9) Correct if necessary the balance with button (6), for monophonic sound on master 1 and 2 set switch (23) in mono position. For monophonic sound on monitor output, set switch (22) in mono position.
- 10) If you like to use the crossfader (14), you can route the channel to the left (X) side of the crossfader by putting the routing switch (7) on CF-X position. Or to the right (Y) side of the

crossfader when you put the routing switch (7) on the CF-Y position. The response curve of the cross fader (14) can be adjusted with the cross fader curve potentiometer (32).

- 11) To change the source, repeat point 3) to 6).
- 12) By turning the headphones select potentiometer (29) more clockwise, you will increase the amount of the main mix signal in the headphones.
- 13) To add a microphone signal, connect the microphone to the MIC input (F). Turn the level control (11) and the talk-over (12) to zero, slide up the MIC fader (15) to maximum and adjust with the level button (11) the volume of the microphone. Adjust with the equalizer (10) the sound of the microphone. To use the talk over, adjust the talk over button (12) (0= no decrease, 10= total decrease). With the pan MIC (17), the DJ microphone signal can be placed somewhere between left and right. Eventually you can connect an external processor (example: compressor or reverb) to the effects insert (G) of the microphone channel.
- 14) The mixed signal can be recorded, simply by connecting a recorder to the analogue (U) or digital (R) record-connectors. Depending on the position of the record-select switch (24) you can decide if the microphone signal is also recorded or not. The mixed signal can also be recorded with a computer through the optional USB connector (S).
- 15) The main mix signal can also be lead to one of the effects insert outputs. This can be done in the same way as leading the signal of an input channel to the effects insert outputs, follow the instructions of point 5). The effects assign indication LED's for the main mix are LED's (25). The effects assignation for the main mix can be done with the main mix effects assign potentiometer (26).
- 16) On the right VU-meters the signal appears selected with the VU2-signal select switch (27). If you like to compare via the headphones and the left VU-meters the pre-fade signal with the output signal, you can do this by putting the rotative switch (27) on the SUM-position. By this the PFL-signal appears on the two left VU-meters and the output-signal on the other two VU-meters.
- 17) If you have an optional Alarm/Music mute priority unit at your disposal, you can mute the music remote controlled. The alarm/music mute connector has 4 connections (GND, NEG, POS, +5V).
The music volume can be controlled following 4 basic principles:

Switch-contact:

Switching of the music remote controlled through a switch-contact in an alarm-central or some other system.

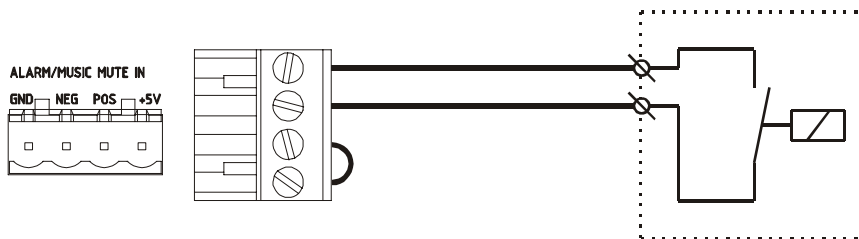

Connect the switching contact between the connection "POS" and "+5V". Place a small wire between the connections "GND" and "NEG". When the switch-contact is open, the music will play normally, when the switch-contact is closed, the music will be muted.

Also the alarm/music mute indicator LED (28) at the frontpanel will light up to indicate the music is muted remote controlled.

Potentiometer:

Controlling the volume remote controlled with a potentiometer.

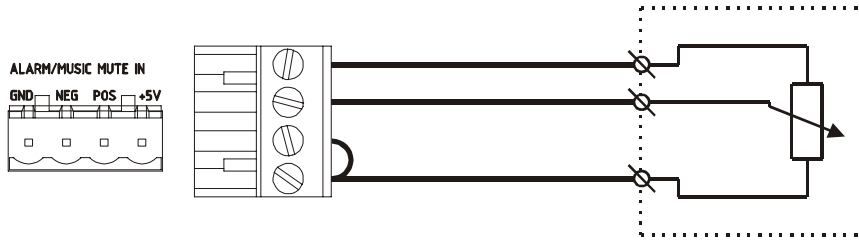

Use a potentiometer with total resistance between 1kilo-ohms and 100kilo-ohms. Connect the potentiometer between connections “GND” and “+5V”, connect the wiper to the connection “POS” (please follow the schematic diagram above). Place also a small wire between the connections “GND” and “NEG”. When the wiper of the potentiometer is turned completely to the “+5V” side (fully counter clockwise), the music will be completely muted, when the wiper is turned to the “GND” side (fully clockwise), the music will play normally. The alarm/music mute indicator LED (28) at the frontpanel will indicate the amount of music-surpression. When the music is totally muted the LED will light up completely. When the music is not muted the LED is turned off.

Variable 5V voltage source:

Controlling the volume with a 0V to 5V voltage source remote controlled.

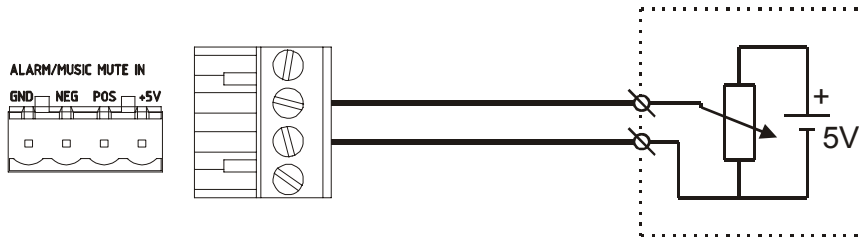

Connect the 0Volts to 5Volts variable voltage source to connections “NEG” and “POS”. Connect the positive wire to the connection “POS” (please follow the schematic diagram above). When the voltage source is 0V, the music will play normally. When the voltage source it’s output voltage rises to 5V, the music will be muted. The alarm/music mute indicator LED (28) at the frontpanel will indicate the amount of music-surpression. When the music is totally muted the LED will light up completely. When the music is not muted the LED is turned off.

0V - 5V output:

Switching on/off the music with a 0Volts or 5Volts switching output.

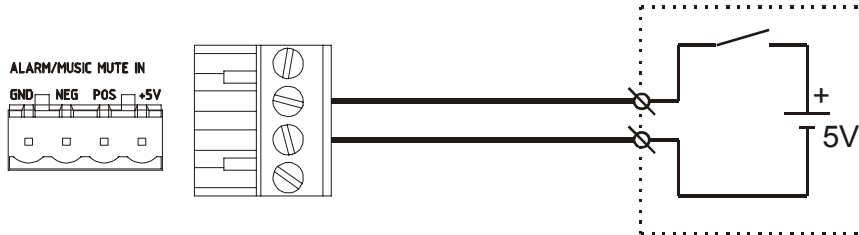

Connect the positive contact of the 0Volts / 5Volts output to the connection "POS" and the other contact to the connection "NEG". When the 0V/5V output sends out 0V, the music will play normally, when there is 5V at this output, the music is muted. The alarm/music mute indicator LED (28) at the frontpanel will light up to indicate the music is muted remote controlled.

- 18) When the music is muted through the alarm/music mute input (N), an alarm message, alarm signal or evacuation message can be played via the priority input (O). Simply connect the alarm message-, alarm signal- or evacuation message player to the priority input RCA connector. For a correct operation, the level must be set in advance. This can be done as follows: turn all other music sources off, put the VU-2 signal select switch (27) on position SUM, start the alarm-message, alarm-signal or evacuation-message, turn up the level with the priority signal input level potentiometer (P) until the green 0dB LED's on the VU-meter (13) lights up sometimes. At that moment the level is set correctly. Later when an alarm has to be given, the alarm system can mute the music through the alarm/music mute input and the message player can be started to play the message.

SUBSONIC FILTER

The two master outputs and the monitor output have a subsonic filter to protect the bass loudspeakers from DC and subsonic signals. This filter cannot be switched off. The filter gives a reduction of 25dB at 10Hz.

Application examples

Large discotheque

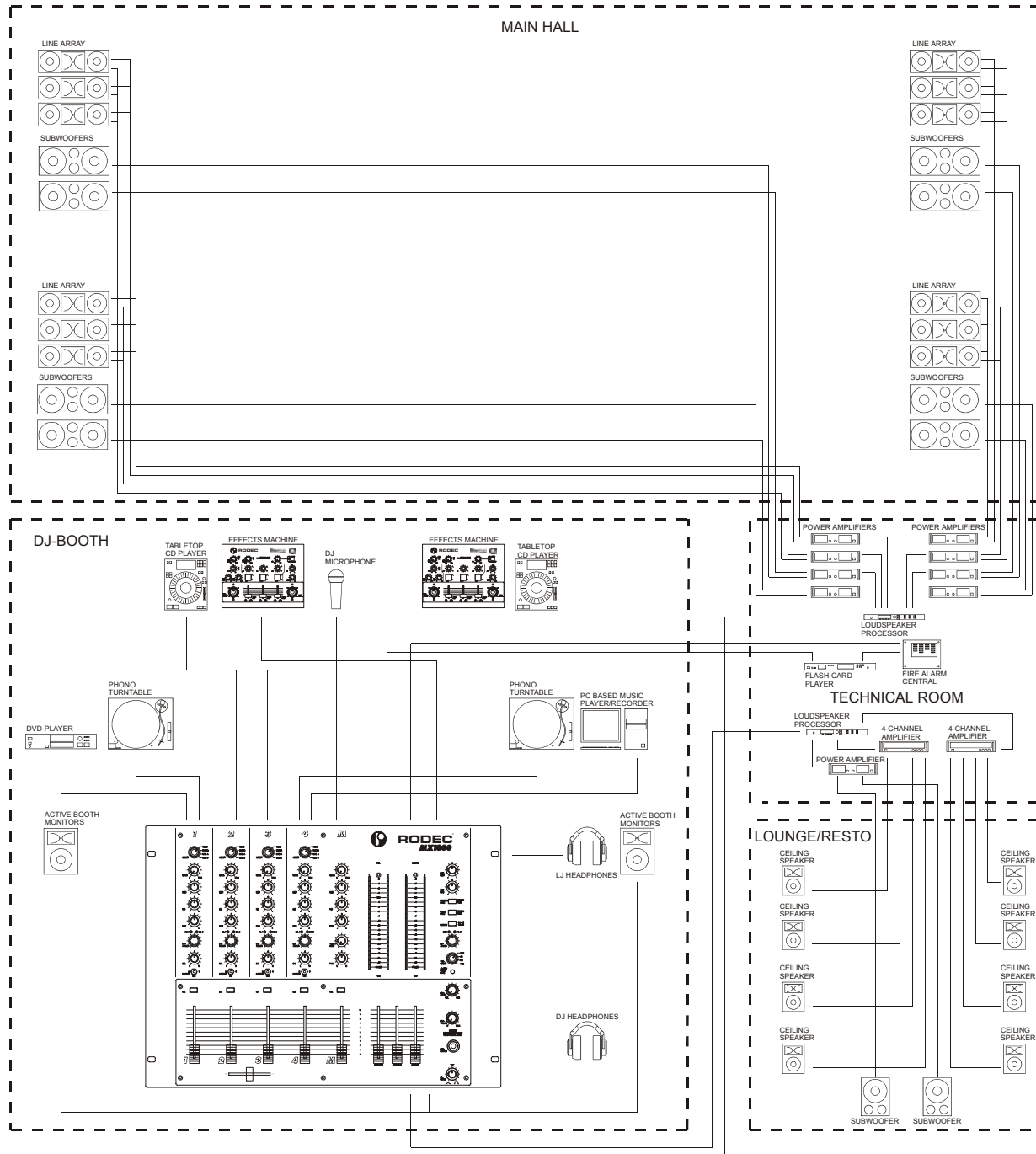

Club

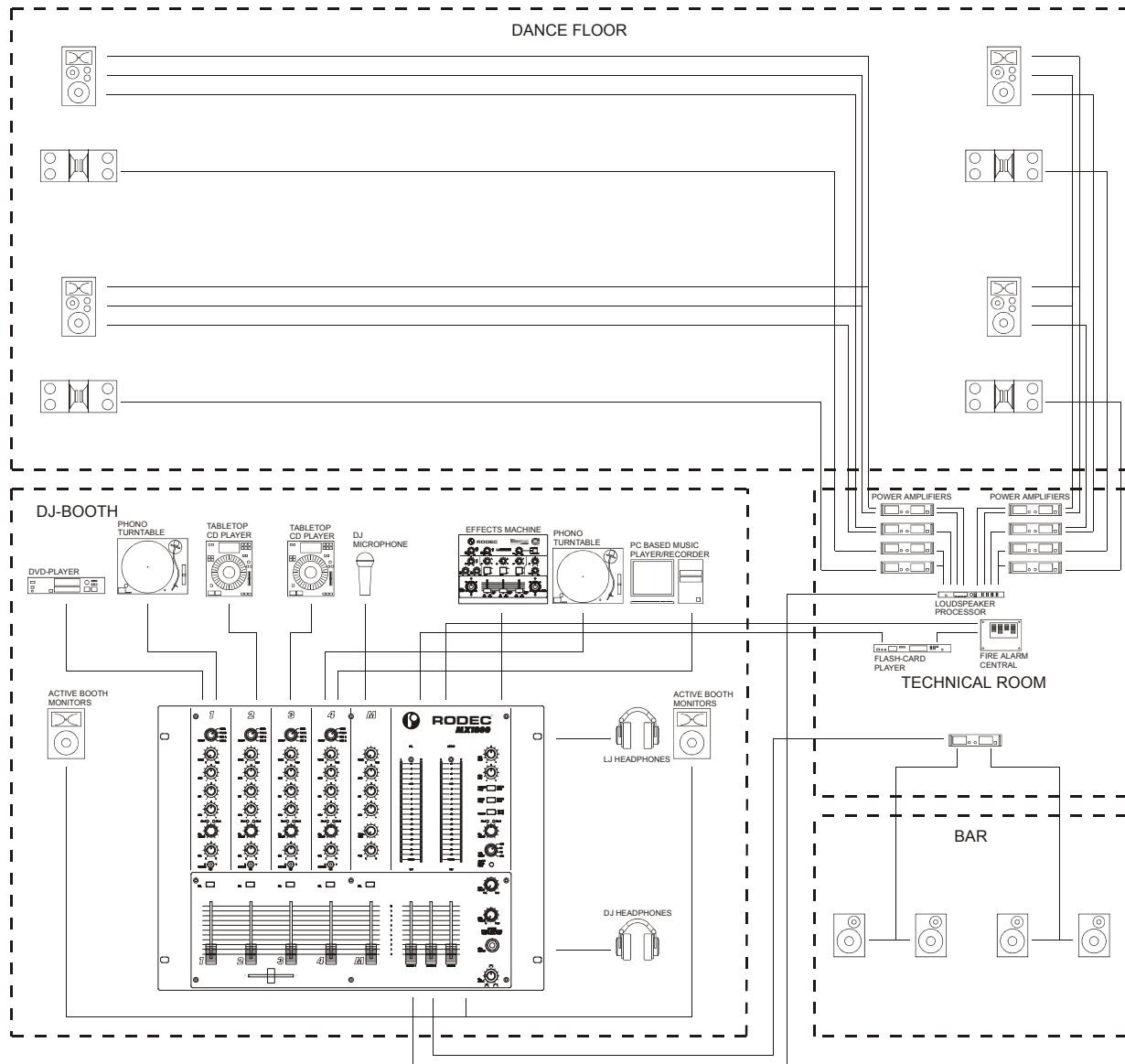

Drive-in

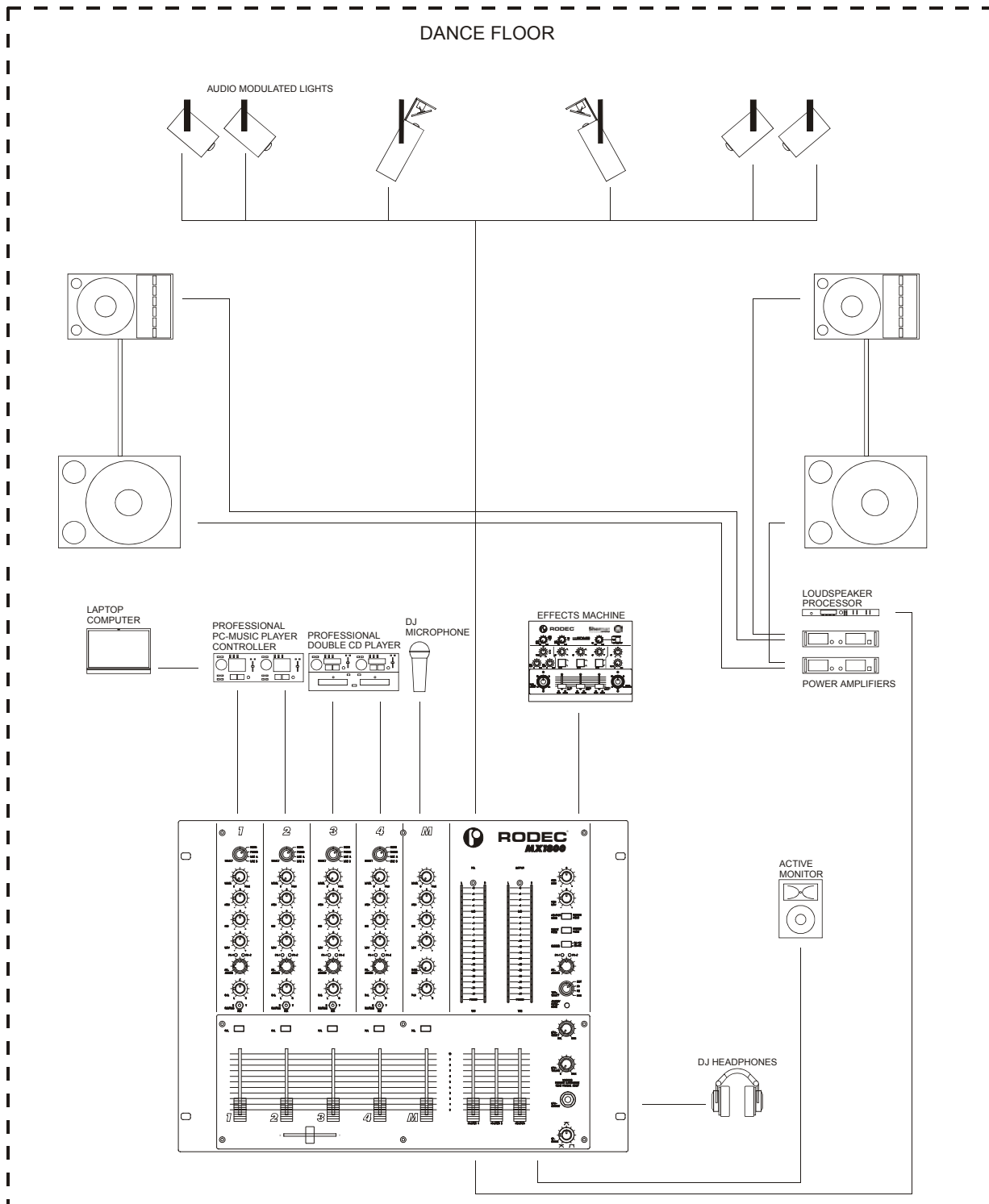

Pub/Resto

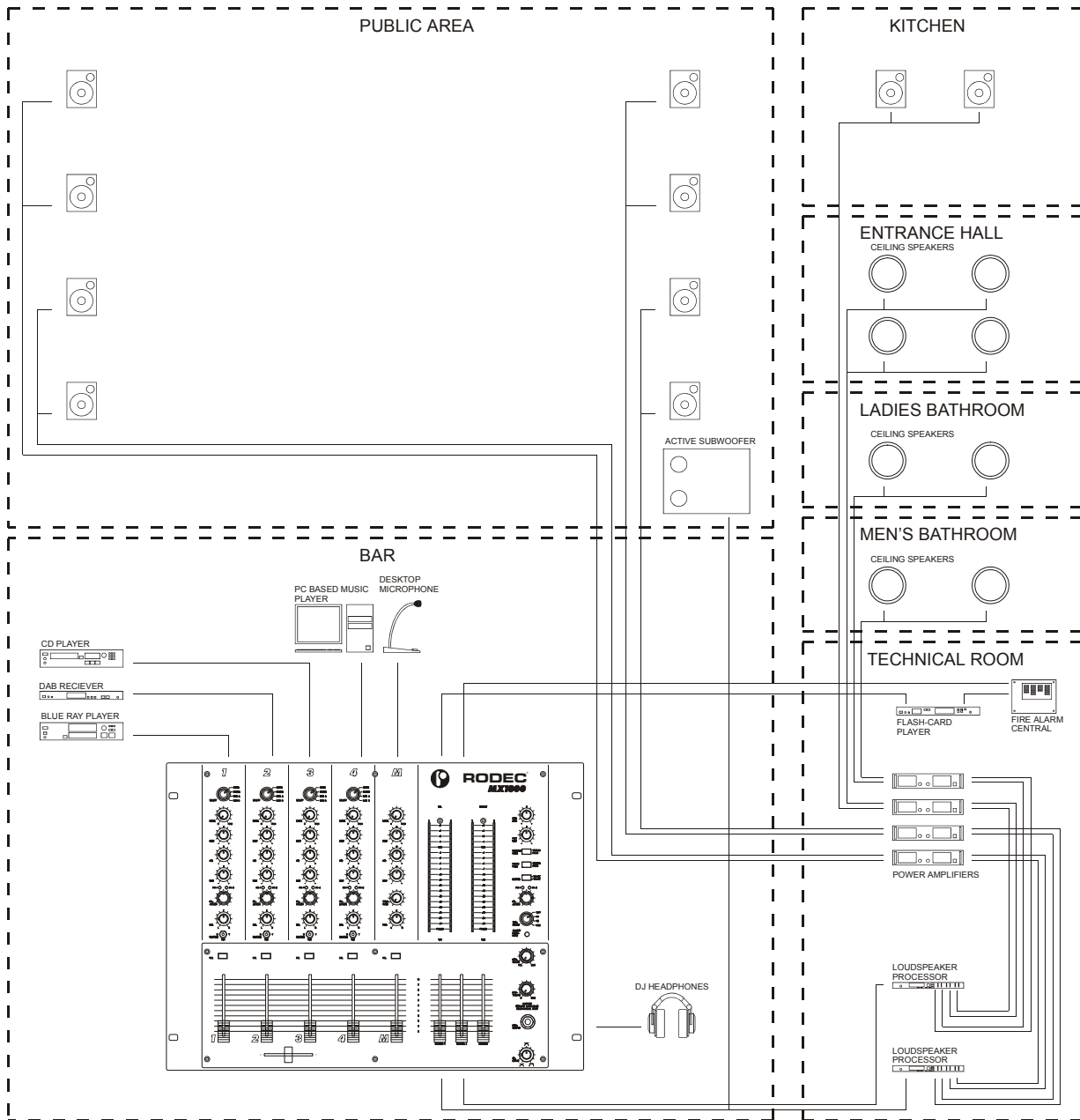

Shop

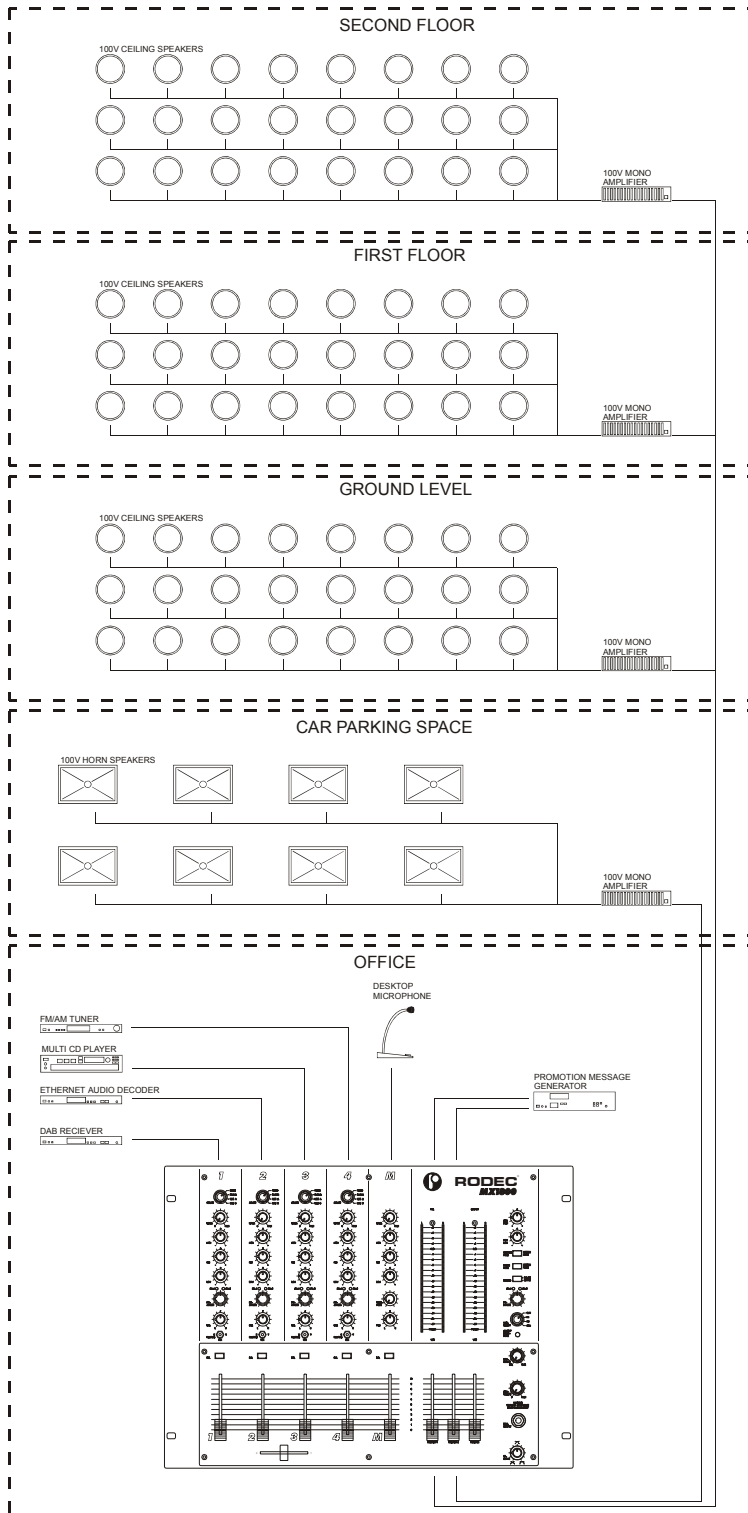

Options

1) **USB I/O set MX00**

Optional input/output kit to connect the mixing panel with a computer. The USB connector contains 1 stereo input signal and 1 stereo record output signal. With this option music can be played from a computer via USB. Simultaneous the mixed music can be recorded via the computer. The option must be built in as follows: First pull off the fader knobs (9, 14, 15, 19 & 20) at the frontpanel. Then unscrew the aluminum fader cover plate (6 screws). Take of this aluminum plate. Then unscrew the bottombox, 3 screws at the frontpanel, one screw at each side and 3 screws at the bottom.

Screw of the hole cover plate (at the backpanel) which covers the desired hole for the USB option set. Place the USB option so that the 6 pole angled connector on the USB PCB fits in the 6 pole angled connector on the input PCB. Screw the screw in the hole in the backpanel to mount the USB option kit. Close the mixing panel again by replacing the bottombox (8 screws), the aluminum fader cover plate (6 screws) and the fader knobs (12 pieces).

Connect the USB I/O set to a computer via a USB-cable. The computer will recognize the USB I/O set. Select the USB I/O set as playback- and recording device in the sound and audio configuration menu of the computer or audio-software.

The USB I/O set MX00 can be ordered at every authorized RODEC-dealer.

Order code: 94 001 0070

2) **Alarm/Music mute/Priority in set MX00**

With this optional set, the music can be muted or decreased in volume remote controlled.

This can be used to connect a fire-alarm system to the mixing panel so that the music mutes automatically when a fire-alarm signal appears. Through the priority input an automatically starting alarm message can be reproduced.

Another application of this set is controlling the output volume of the mixing panel remote controlled. In this way another person than the DJ can decide at every moment how loud the music is played in the venue.

The option must be built in as follows: First pull off the fader knobs (9, 14, 15, 19 & 20) at the frontpanel. Then unscrew the aluminum fader cover plate (6 screws). Take of this aluminum plate. Then unscrew the bottombox, 3 screws at the frontpanel, one screw at each side and 3 screws at the bottom.

Screw of the hole cover plate (at the backpanel), which covers the holes for the Alarm/Music mute/Priority in set. First connect the 6 pole connector of the optional alarm/music mute/priority in set to the 6 pole connector on the output PCB (68 001 0050). Screw the alarm/music mute/priority set to the backpanel with the screw (delivered together with the set). Close the mixing panel again by replacing the bottombox (8 screws), the aluminum fader cover plate (6 screws) and the fader knobs (12 pieces). Now the alarm/music mute/priority in set is ready to use.

The alarm/music mute/priority in set MX00 can be ordered at every authorized RODEC-dealer.

Order code: 94 001 0071

3) **Digital optical input channel fader MX00 set**

Users can upgrade their mixing panel with digital faders on the music input channels. The digital faders replace the standard analogue faders. The option must be built in as follows: First pull off the fader knobs (9, 14, 15, 19 & 20) at the frontpanel. Then unscrew the aluminum fader cover plate (6 screws). Take of this aluminum plate. Unscrew the channel fader, which you like to replace (2 screws). Pull off the 4 pole flat cable at the input PCB. Place the 10 pole flatcable (delivered together with the digital optical input channel fader set) on the 10 pole connector (right below the PFL switch) on the input channel PCB. Connect the other side of the flatcable to the digital optical input channel fader. Screw the fader to the frontpanel (2 screws), attention, the 10 pole connector on the fader PCB must be placed at the side of the crossfader (14). Replace the aluminum fader cover plate and fader knobs. The digital optical input channel fader is ready to use.

The digital optical input channel fader MX00 set can be ordered at every authorized RODEC-dealer.

Order code: 94 001 0072

4) **Digital optical crossfader MX00 set**

The standard analogue crossfader can be upgraded by a digital optical crossfader. The option must be built in as follows: First pull off the fader knobs (9, 14, 15, 19 & 20) at the frontpanel. Then unscrew the aluminum fader cover plate (6 screws). Take of this aluminum plate. Then unscrew the bottombox, 3 screws at the frontpanel, one screw at each side and 3 screws at the bottom. Unscrew the crossfader (2 screws). Pull off the 4 pole flatcable of the crossfader on the output PCB. Place the 10 pole flatcable (delivered together with the digital optical crossfader set on the 10 pole connector on the output PCB. Connect the other side of the flatcable to the digital optical crossfader. Screw the digital optical crossfader to the frontpanel (2 screws), attention, the 10 pole connector on the fader PCB must be placed at the opposite side of the output PCB. Replace the bottombox (8 screws), the aluminum fader cover plate (6 screws) and fader knobs. The digital optical cross fader is ready to use.

The digital optical cross fader MX00 set can be ordered at every authorized RODEC-dealer.

Order code: 94 001 0073

5) **Standard knobs set MX00 series**

The knobs of a MX00 series mixing panel can be ordered in a set. For a MX3000 you need 2 of these sets to replace all the knobs.

The standard knobs set MX00 series can be ordered at every authorized RODEC-dealer.

Order code: 94 001 0074

6) **Fader knobs BX/CX/MX MKIII/MX00 series**

The fader knobs of a MX00 series mixing panel can be ordered in a set. For a MX3000 you need 2 of these sets to replace all the fader knobs.

The fader knobs BX/CX/MX MKIII/MX00 series can be ordered at every authorized RODEC-dealer.

Order code: 94 001 0041

Specifications

0dBm = 0.775V RMS

Nominal analogue input levels:

- Line A asymmetrical (RCA): 500mV / 50k Ω
- Line B asymmetrical (RCA): 500mV / 50k Ω
- Phono asymmetrical (RCA gold plated): 5.2mV / 50k Ω
- Microphone (channel 1 – 4) symmetrical (XLR): 9.1mV / 3.6k Ω
- Microphone symmetrical (XLR or 1/4" TRS JACK): 4.2mV / 1.8k Ω
- Effects return (1/4" TRS JACK): 775mV / 10k Ω
- Priority in (optional) (RCA): 500mV / 1.5k Ω

Nominal analogue output levels:

- Master 1 asymmetrical (RCA): 775mV / 10k Ω
- Master 1 symmetrical (XLR): 1.55V / 600 Ω
- Master 2 symmetrical (XLR): 1.55V / 600 Ω
- Monitor symmetrical (XLR): 1.55V / 600 Ω
- Record asymmetrical (RCA): 500mV / 10k Ω
- Effects send asymmetrical (1/4" TRS JACK): 775mV / 10k Ω
- Headphones (1/4" TRS JACK):
 - 8 Ω : (1kHz – 1%THD) 417mW (1.8V) / 1.1W music power
 - 32 Ω : (1kHz – 1%THD) 1.0W (5.7V) / 1.7W music power
 - 600 Ω : (1kHz – 1%THD) 520mW (17.7V) / 0.6W music power

Digital input:

- Line B (RCA): S/P DIF IEC 958 type II 32kHz – 192kHz
- USB (optional): 32kHz - 48kHz 16bit

Digital output:

- Record (RCA): S/P DIF IEC 958 type II 44.1kHz
- USB (optional): 11.025kHz - 48kHz 16bit

Signal headroom: 20.0dB @ 1kHz / THD < 0.05%

Crosstalk:

- Left to right of an input channel: >60dB @ 1kHz
- Channel to channel: >86dB @ 1kHz

Frequency response: +/- 0.25 dB from 20Hz to 20kHz

Subsonic filter: -25dB at 10Hz

Dynamic range: 103dB

Signal to noise ratio: 90dB

Total harmonic distortion: < 0.006%

Music equalizer: - Low: +10dB / -21dB at 100Hz
 - Mid: +10dB / -21dB at 1kHz
 - High: +10dB / -21dB at 10kHz

Microphone equalizer: - Low: +/- 12dB at 100Hz
 - Mid: +/- 12dB at 1kHz
 - High: +/- 12dB at 10kHz

Monitor output equalizer: - Low: +12dB / -12dB at 100Hz
 - High: +12dB / -12dB at 10kHz

Power supply voltage: 90VAC – 264VAC

Power supply frequency: 47Hz – 63Hz

Power consumption: 42W (On), 69W (Full load), 5W (Stand by)

Operating temperature: 0°C (32°F) – 40°C (104°F)

Operating humidity: 5% - 90% (no condensation)

Mechanical specifications:

Frontpanel dimensions (W x D): 482.0mm (19.0”) x 355.0mm (14.0”) (8HE)

Bottombox dim. (W x D x H): 442.0mm (17.4”) x 343.0mm (13.5”) x 110.0mm (4.3”)

Panel cut out dimensions (W x D): 446.0mm (17.6”) x 347.0mm (13.7”)

Packed box dimensions (W x D x H): 523mm (20.6”) x 414mm (16.3”) x 207mm (8.1”)

Weight: 6.62kg (14.59lbs)

Packed weight: 7.76kg (17.11lbs)

Explanatory words list

Amplitude: The amplitude is the size, the strength of a vibration. This can be a mechanical vibration, for example a snare of a guitar, or the, from that arisen, sound wave or from any other cyclical varying appearance in time. Because any waveform always varies in size, the value of the wave will also vary. The amplitude is the value from zero to the maximum hit out or strength of the wave.

Analogue signal: (synonym: analog signal) An analogue signal is any time continuous signal. The amplitude of the signal varies continuously in function of time. Human-ears can only hear analogue signals (sounds). Digital sounds must always be converted to analogue signals to make them audible.

Asymmetrical (synonym: unbalanced): An unbalanced line is a transmission line, usually coaxial cable, whose conductors have unequal impedances with respect to ground.

Balance: Balance means the amount of signal from each channel reproduced in a stereo audio recording. Typically, a balance control will have 0dB of gain in the center position for both channels, and attenuate one channel as the control is turned, leaving the other channel at 0 dB.

Binary: The binary numeral system, or base-2 number system, is a numeral system that represents numeric values using two symbols, usually 0 and 1.

Bit: A bit is a binary digit, taking a value of either 0 or 1.

CD: Abbreviation for Compact Disc. It is an optical disc used to store digital data, originally developed for storing digital audio. The CD, available on the market since late 1982, remains the standard playback medium for commercial audio recordings to the present day. An audio CD consists of one or more stereo tracks stored using 16-bit PCM coding at a sampling rate of 44.1 kHz. Standard CDs have a diameter of 120 mm and can hold approximately 80 minutes of audio.

Crossfader (synonyms: CF, X-fader or XF): A crossfader essentially functions like two faders connected side-by-side, but in opposite directions. It allows a DJ to fade one source out while fading another source in at the same time with one knob.

DAB: Digital Audio Broadcasting (DAB), is a technology for broadcasting of audio using digital radio transmission.

DAT: Digital Audio Tape is a signal recording and playback medium. The audio data is stored on a magnetic tape. It uses 48, 44.1 or 32 kHz sampling rate and 16 bits quantization.

dB: Abbreviation for decibel (1/10 of a Bel). dB is a logarithmic unit of measurement that expresses the size of a physical quantity relative to a reference level. Its logarithmic nature allows very large or very small ratios to be represented by a convenient number. The decibel is commonly used in acoustics to quantify sound levels relative to some 0dB reference. The reference level is typically set at the threshold of human perception. A reason for using the decibel is that the ear is capable of detecting a very large range of sound pressures.

Digital signal: A digital signal is one that uses discrete values (electrical voltages), rather than a continuous spectrum of values (ie, as in an analogue signal).

DJ: Abbreviation for Disc Jockey. A DJ is a person who plays pre-recorded (not live) music, either or not in front of an audience.

Dry signal: Opposite of "Wet signal". This is the signal as it is, without added deformation, effects, tone-manipulation, etc.

DVD: Also known as "Digital Versatile Disc" and "Digital Video Disc", is a popular optical disc storage media format used for data storage, mainly movies. Most DVDs are of the same dimensions as compact discs, but store more than 6 times the data.

Equalizer: Equalization (or equalisation, EQ) is the process of changing the frequency envelope of a sound. The audio band is subdivided in 2, 3 or more subbands, the volume of each of these bands can be amplified or attenuated with an equalizer.

Fader: Is a linear potentiometer. Faders are mostly used to increase or decrease in the level of an audio signal. By moving the knob, the volume increases or decreases. A fader can be either analogue, a movement of the knob will result in a change of the resistance or digital, the movement of the knob generates a binary code, this code is used to change the volume.

Flash card: A memory card or flash memory card is a solid-state (no moving parts) electronic flash memory data storage device, which can be electrically erased and reprogrammed.

FX: Abbreviation for effects-unit. An effects unit is used to manipulate the sound of music or voice. Some effect units transform the sound completely, others just color the sound picture in a minor way.

Frequency: Frequency is the measurement of the number of occurrences of a repeated event per unit of time. The result is measured in hertz (Hz). A baby can hear tones with frequencies from 20Hz to 20000 Hz (20kHz), but these frequencies become more difficult to hear as people age. When a tone with a frequency of 20Hz is played by a loudspeaker, the loudspeaker will reciprocate 20 times per second.

HD: Abbreviation of hard disc. It is a non-volatile storage device, which stores digitally encoded data on rapidly rotating platters with magnetic surfaces.

Headphones: Are a pair of tiny loudspeakers that are hold close to humans ears. DJ's use types with pads that go around the ears, usually very large and very comfortable.

Hz: Abbreviation of Hertz, named after the German physicist Heinrich Rudolf Hertz. The hertz is the unit of frequency. Its base unit is cycles per second. Each musical note corresponds to a particular frequency which can be measured in hertz.

I/O: Abbreviation for input / output

Insert: An insert is an access point built into the mixing console, allowing the user to add external line level devices into the signal flow.

JACK: It is cylindrical in shape, typically with three contacts (TRS), although sometimes with two (a TS connector) or four (a TRRS connector). TRS stands for Tip, Ring and Sleeve. In audio-systems, it is used to connect headphones, microphones, effects-units, electrical musical instruments, etc.

kHz: Abbreviation of kilo Hertz, is 1000 Hertz (see Hz)

LED: Abbreviation of Light emitting diode. Is an electronic component that emits light when an electrical current flows through it.

Loudspeaker: A loudspeaker, speaker, or speaker system is an electromechanical transducer that converts an electrical signal into sound. The term loudspeaker can refer to individual devices (or drivers), and complete systems consisting of an enclosure incorporating one or more drivers and additional electronics.

Line: Line level is a term used to denote the strength of an audio signal used to transmit analogue sound information between audio components such as CD-players, DVD-players, input signals of audio amplifiers, mixing consoles, etc. Sometimes also called AUX (auxiliary) signals.

MD: Abbreviation of Mini Disc. It is a rewriteable magneto-optical disc-based data storage device for storage of up to 80 minutes of digitalized audio.

Micro: Abbreviation of microphone. (synonym: mike or mic) Is an acoustic to electric transducer that converts sound into an electrical signal.

Mono: Abbreviation of monaural. Typically there is only one microphone, one loudspeaker, or, in the case of headphones or multiple loudspeakers, they are fed from a common signal path, and in the case of multiple microphones, mixed into a single signal path at some stage.

MP3: Abbreviation of MPEG-1 Audio Layer 3. This is an audio encoding format. It uses a lossy compression algorithm that is designed to greatly reduce the amount of data required to represent the audio recording, yet still sound like a faithful reproduction of the original uncompressed audio to most listeners.

Mute: If an audio signal is muted, it is turned off or it's volume is turned to a lower level.

Pan: Abbreviation of panoramic or panning. Panning is the spread of a monaural signal in a stereo or multi-channel sound field. A typical pan control is constant power. At one extreme, the sound appears in only one channel. In the middle, the sound is decreased in that channel by 3 dB, and the other channel is brought up to the same level, so that the overall sound power level is always constant.

PCM: Abbreviation of Pulse Code Modulation is a digital representation of an analogue signal where the magnitude of the signal is sampled regularly at uniform intervals, then quantized to a series of symbols in a digital (usually binary) code.

PFL: Abbreviation of Pre Fader Listening. (synonym: cue) This is a function in an audio mixing panel to allow the user of the mixing panel to listen to the music (mostly via headphones) before the audience hears the music.

Phono: Abbreviation of phonograph. Also called turntable, record player or pick-up. Is a device to play music from vinyl records.

Potentiometer: Is an electrical device, which has a user-adjustable resistance. Usually, this is a three-terminal resistor with a sliding contact in the center (the wiper). By moving the wiper, the resistance changes. These changes are used to to change the characteristics of the audio signal.

Quantized: Quantization is the process of approximating a continuous range of values (or a very large set of possible discrete values) by a relatively small set of discrete symbols or integer values.

RCA (cinch, tulip): Is a type of electrical connector that is commonly used in the audio/video market. The name "RCA" derives from the Radio Corporation of America, which introduced the design by the early 1940s to allow phonograph players to be connected to amplifiers. Now these connectors are used for connections between amplifiers, CD-players, phono-turntables, etc. For analogue audio you need 2 of these connectors for a stereo signal. For digital audio (S/P DIF) only one connector is needed for a stereo signal. The connectors are colour coded: Left or mono -> White, Right -> Red, S/P DIF -> Orange.

Rec (recording): Sound recording is the electrical inscription of sound waves, usually used for the voice or for music. The two main classes of sound recording technology are analogue recording and digital recording.

RIAA: RIAA equalization is a specification for the correct playback of vinyl records, established by the Recording Industry Association of America (RIAA). The purpose of the equalization is to permit greater playback times, improve sound quality, and to limit the physical extremes that would otherwise arise from recording analogue records without such equalization. A record is cut with the low frequencies reduced and the high frequencies boosted, and on playback the opposite occurs. The result is a flat frequency response.

Sample: In music, sampling is the act of taking a portion, or sample, of one sound recording and reusing it as an instrument or element of a new recording. This is typically done with a sampler, which can be a piece of hardware or a computer program.

In signal processing, sampling is the reduction of a continuous signal to a discrete signal. Sampling picks out samples from a continuous signal at a certain frequency. When it is necessary to capture audio covering the entire 20-20kHz range, such as when recording music, audio waveforms are typically sampled at 44.1 kHz (CD) or 48 kHz (professional audio).

Sound: Sound can be perceived by the sense of hearing. By sound, we commonly mean the vibrations that travel through air and are audible to people. Humans and many animals use their ears to hear sound, but loud sounds and low-frequency sounds can be perceived as vibrations by other parts of the body via the sense of touch. Sound propagates as waves of alternating pressure, causing local regions of compression and rarefaction.

S/P DIF: Abbreviation for Sony / Philips digital interconnect format. It specifies a protocol for carrying digital audio signals between devices.

Stereo: Stereophonic sound is the reproduction of sound, using two independent audio channels. Stereophonic sound attempts to create an illusion of location for various instruments within the original recording.

Subsonic signal: This is an audio signal with frequency below 20Hz. This signal is not audible, it only creates air movement that can be felt.

SUM signal: This signal is the proportional summation (mix) of all input signals. Also called main mix signal.

Symmetrical (synonym: balanced): A balanced line or balanced signal pair is a transmission line consisting of two conductors of the same type, and equal impedance to ground and other circuits. Balanced lines are operated with differential signals, one of which is the inverse of the other. Balanced lines reduce the amount of noise per distance, allowing a longer cable run to be practical. This is because electromagnetic interference will affect both signals the same way. Similarities between the two signals are automatically removed at the end of the transmission path when one signal is subtracted from the other.

Talk-over (synonym: voice-over, ducker): It is an effect where the level of one signal is reduced by the presence of another signal, through the use of side chain compression. A typical application is to automatically lower the level of the musical background when a talk-over starts, and to automatically bring the level up again when the talk-over stops.

THD: Abbreviation of Total Harmonic Distortion. When a signal passes through a non-linear device, additional content is added at the harmonics of the original frequencies. THD is a measurement of the extent of that distortion.

USB: Abbreviation for Universal Serial Bus. It is a serial bus standard to transport data between (mostly computer related) devices.

Volume: The amount of audio level. If the volume increases, the audio level will increase, which results in a louder sound.

VU: Abbreviation of volume units. A VU meter is often included in audio equipment to display a signal level. It is intentionally a "slow" measurement, averaging out peaks and troughs of short duration to reflect the perceived loudness of the material.

Wave: A wave is a mode of energy transfer from one place to another, often with little or no permanent displacement of the particles of the medium. Mechanical waves require a medium to transverse the distance, electromagnetic waves can travel through a vacuum.

Wet signal: Opposite of "Dry signal". This is the signal inclusive added deformation, effects, tone-manipulation, etc.

XLR: This is a connector invented by Cannon. Originally the "Cannon X" series, subsequent versions added a Latch ("Cannon XL") and then a Rubber compound surrounding the contacts, which led to the abbreviation XLR. The most common is the 3-pin XLR3, used almost universally as a symmetrical audio connector for high quality microphones and connections between equipment.

Manufactured by:

Transtel – Sabima NV
Duboisstraat 50
B-2060 Antwerp
Belgium

Tel: 00 32 (0)3 237 36 07
Fax: 00 32 (0)3 216 97 62
e-mail: info@rodec.com
URL: <http://www.rodec.com>