

# ColorWash 700E AT

## Source

- Lamp: Compact high-pressure metal halide lamp
- Base: PGJX50
- Approved model: Philips MSR Gold 700™ FastFit
- Control: Automatic and remote on/off
- Ballast: Electronic

## Optical System

- Dichroic glass reflector for maximising the light efficiency
- Front Fresne lens of diameter of 200 mm
- Beam angle: 6° - 45°

## Electrical Specification

- Power supply: Electronic auto-ranging
- Input voltage range: 100-240 V AC, 50/60Hz
- Power consumption: 890 VA

## Mechanical Specification

- Height: 597 mm (23.5") - head in horizontal position
- Width: 514 mm (20.2")
- Depth: 499 mm (19.7")
- Weight: 30.4 kg (67 lbs)
- Fixation option: Pan/Tilt-lock mechanism

## Thermal

- Maximum ambient temperature (Ta): 40°C (104°F)
- Maximum surface temperature: 120°C (248°F)

## Control and Programming

- Setting & Addressing: ROBE Navigation System (RNS)
- Protocol: USITT DMX-512, support RDM
- Control channels: 18, 20, 21, 22, 23 or 24
- 6 DMX protocol modes
- 3-editable programs, each up to 99 steps
- Stand-alone operation
- Display: Blue/white LCD graphic
- Pan/Tilt resolution: 16-bit
- Movement control: Tracking and vector
- Colour wheel positioning: 8- or 16-bit
- Beam shaper: 8- or 16-bit
- Zoom: 8- or 16-bit
- Dimmer: 8- or 16-bit
- Ethernet port: Art-Net protocol, ready for ACN
- Data in/out: Locking 3-pin & 5-pin XLR
- Built-in analyser for easy fault finding

## Electromechanical Effects

- Cyan: 0 - 100%
- Magenta: 0 - 100%
- Yellow: 0 - 100%
- CTO: 0 - 100%
- Colour wheel: 7 replaceable "SLOT&LOCK" dichronics filters + open
- Beam shaper: Indexable, continuous rotation in both directions at different speed
- Dimmer/Shutter: Full range dimming and variable strobe effect, electronic strobbing "ZAP"
- Motorized zoom
- Pan: 530°
- Tilt: 280°

## Rigging

- Mounting points: 4 pairs of ¼-turn locks
- 2x Omega bracket with ¼-turn quick locks
- Safety chain/rope attachment point

## Optional Accessories

- Module of front wide-angle lens D200



# ColorWash 700E AT



# ROBE

w w w . r o b e . c z

HQ & Factory: ROBE Lighting s.r.o. ■ Házovice 2090 ■ 756 61 Rožnov p. Radhoštěm ■ Czech Republic ■ Tel.: +420-571-751 500 ■ Fax: +420-571-626 337 ■ E-mail: robe@robe.cz

UK: ROBE UK Ltd. ■ Northampton, UK ■ Tel.: 01604 741000 ■ E-mail: info@robeuk.com ■ America: ROBE Lighting Inc. ■ Florida, FL, USA ■ Tel.: (954) 615-9100 ■ E-mail: info@robelighting.com

South-East Asia: ROBE S.E.A. ■ Singapore ■ Tel.: +65-8118 6665 ■ E-mail: info@robe-sea.com

September © 2007 Robe Lighting s.r.o. All specifications subject to change without notice.

# ROBE



# ColorWash 700E AT

**ROBE**



Brand New Concert 07 - UK



Sundial Theatre - UK



Glastonbury Festival 07 - UK

The ColorWash 700E AT is the first Wash fixture using the MSR GOLD 700 FastFit lamp in the Robe range.

This powerful moving head offers a full CMY+ CTO colour mixing system, a colour wheel with 7 replaceable "SLOT&LOCK" dichroic filters, a rotating beam shaper and a linear zoom range of 6° - 45°.

The ColorWash 700E AT is an ideal tool for large theatres, live and television shows, and for all types of installations from multi-purpose venues to large clubs.

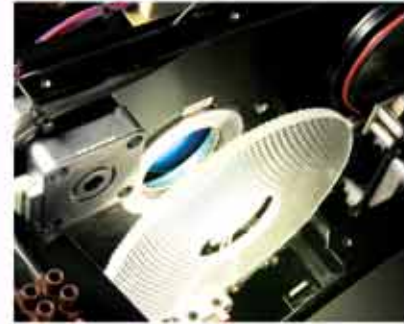
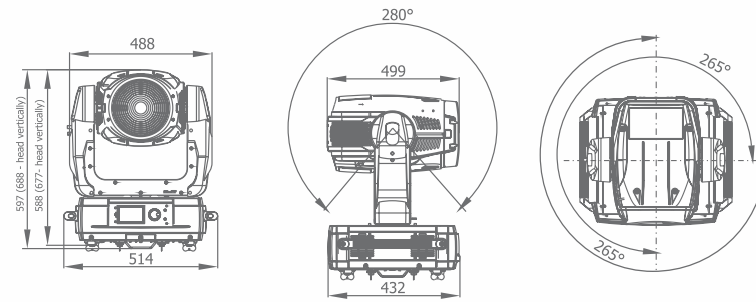

## Photometric Diagrams

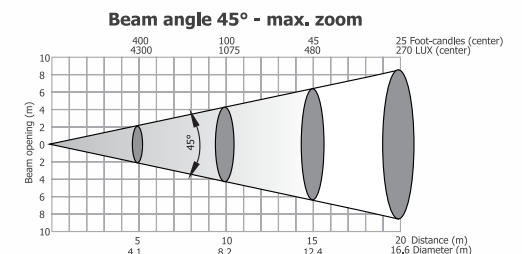
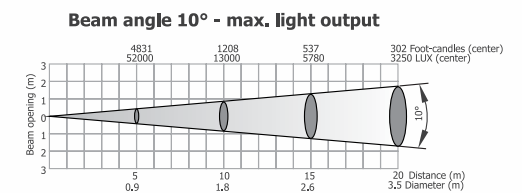
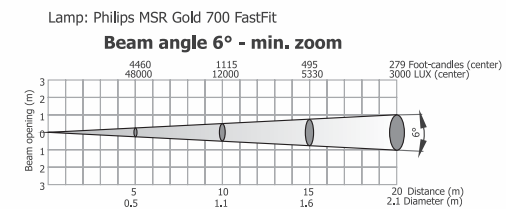

Product information