

# Hookup Diagrams

## Stereo

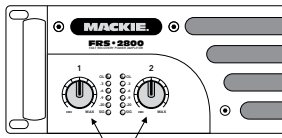

In STEREO mode, both gain controls are used to achieve a nice balance

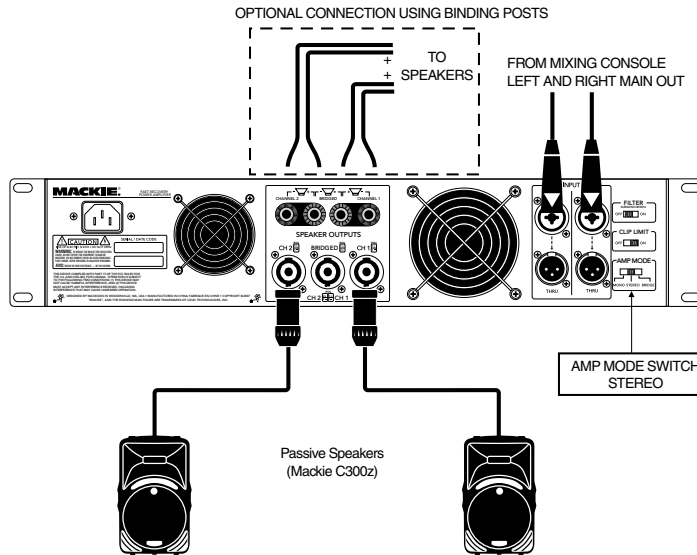

## Dual mono

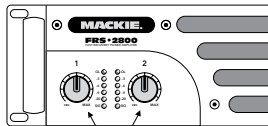

In MONO mode, both gain controls are used to achieve a nice balance

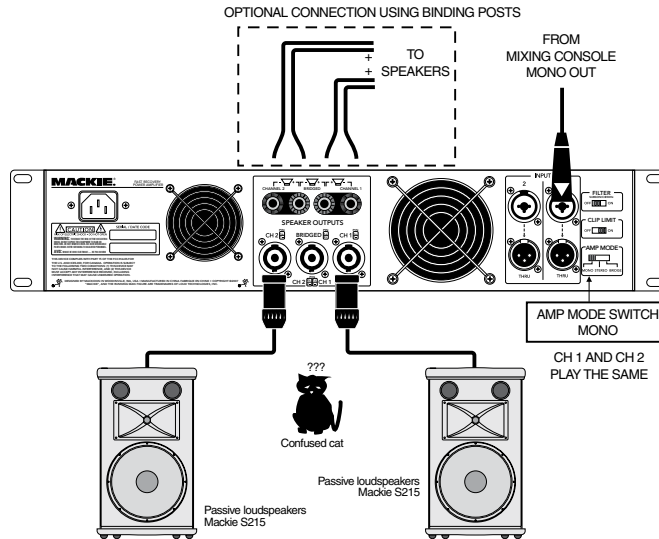

## Bridged mono

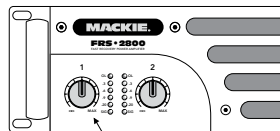

In BRIDGED mode, only use this gain control

If you have two amplifiers, each could power a single speaker in bridged mono, to make a very powerful stereo system. Use a stereo feed from your mixing console, the left goes to one amp, and the right goes to the other.

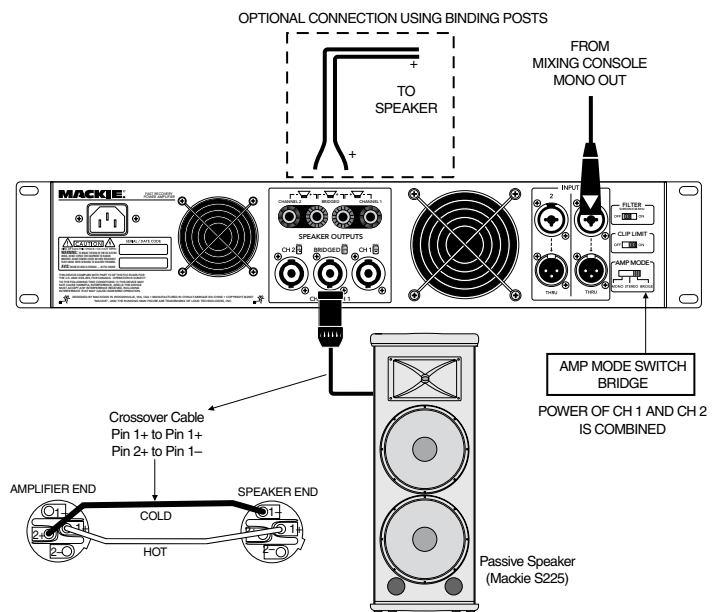

## STEREO, DUAL MONO, AND BRIDGED MONO

## Daisy-chaining two stereo amplifiers

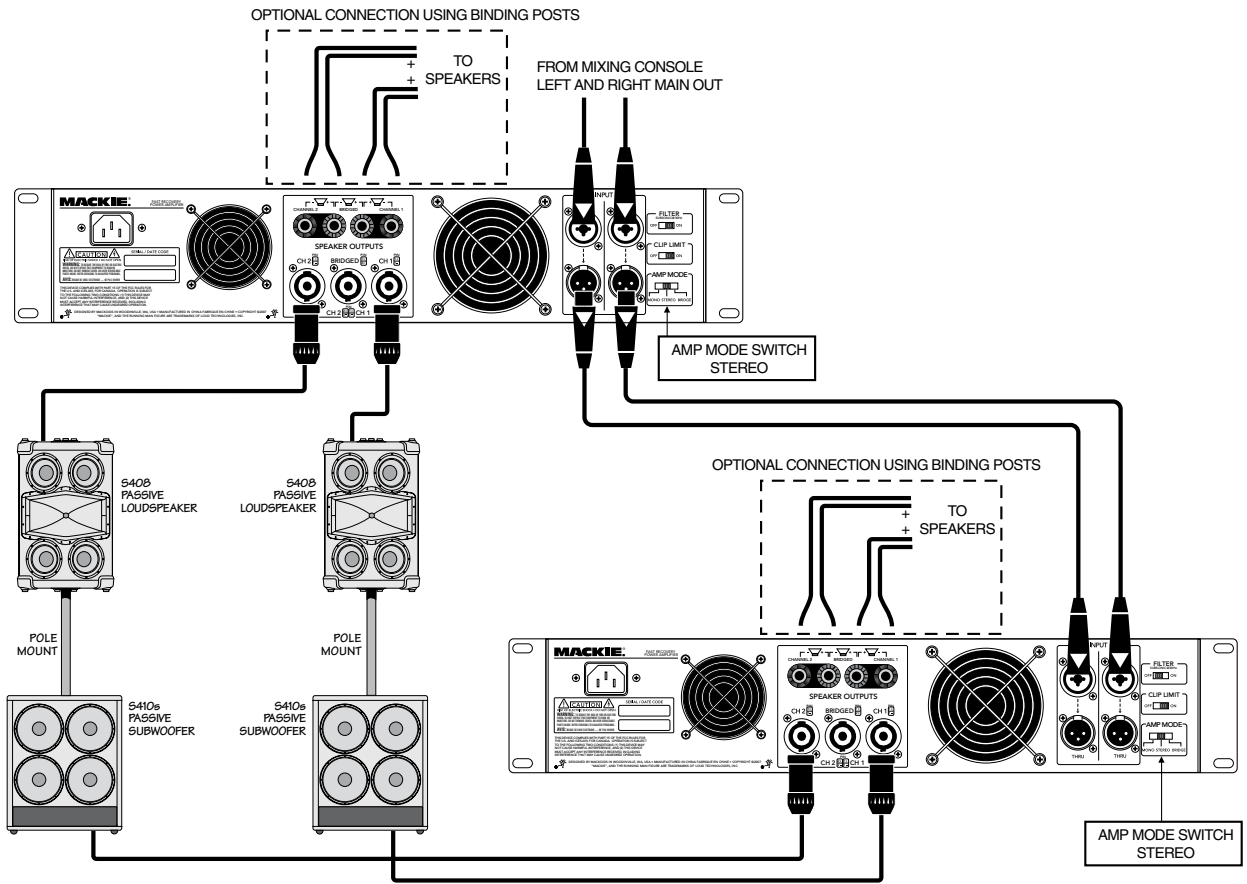

## Running stereo speakers with minimum length of speaker cable runs

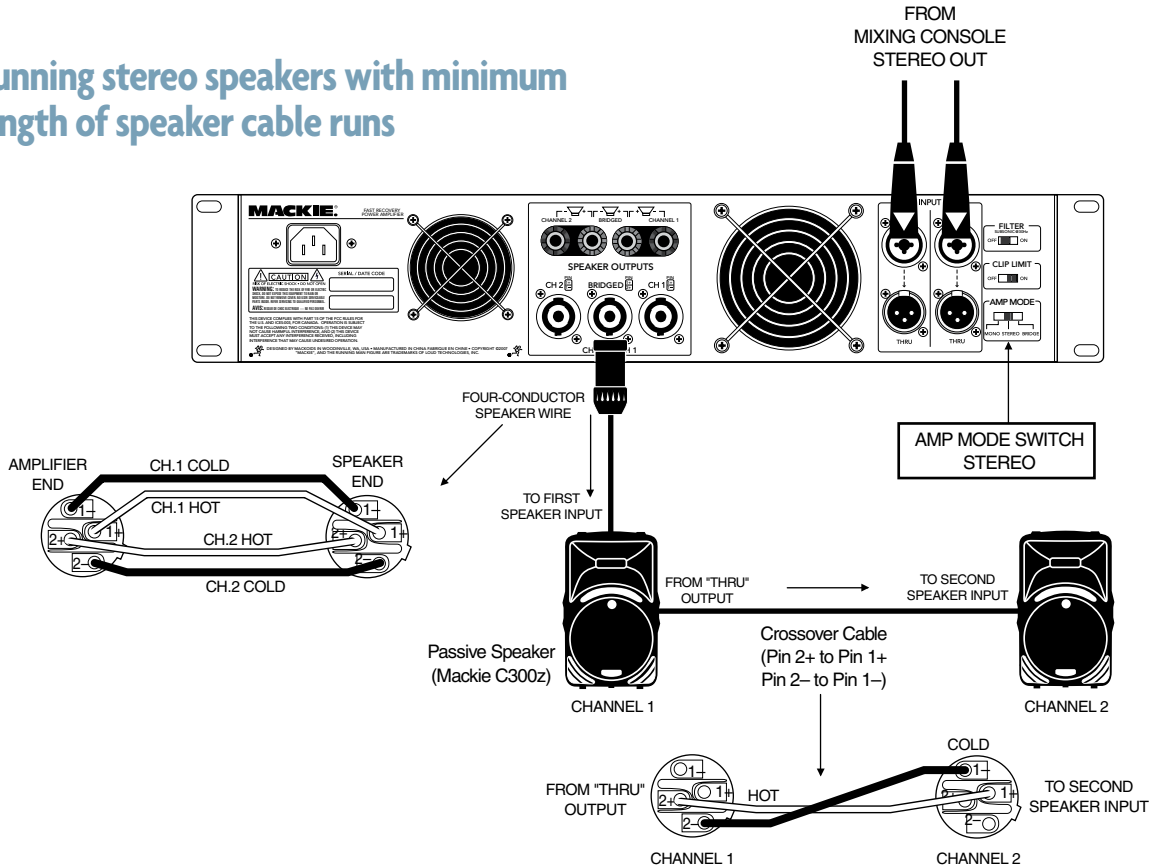

### DAISY CHAINING AND A SPECIAL CASE