

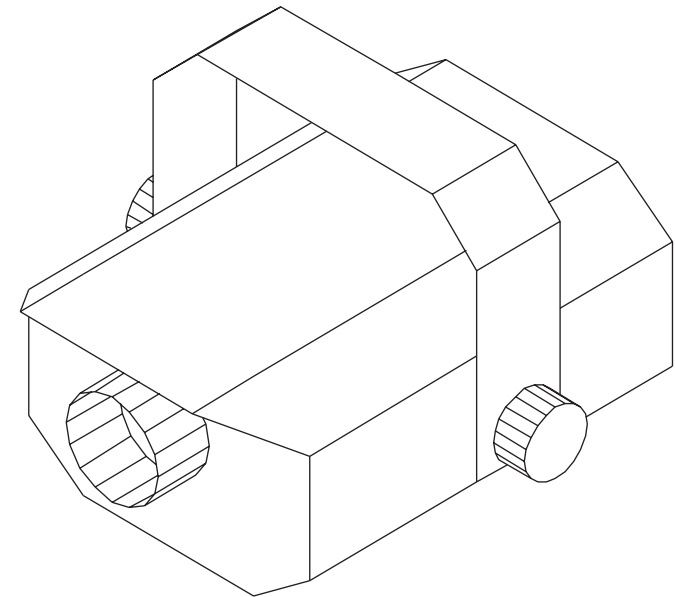

Manufactured By  
Martin Manufacturing (UK) Plc.  
Belvoir Way  
Fairfield Ind. Est.  
Louth  
Lincolnshire, LN11 0LQ  
UK  
Tel: +44(0)1507 604399  
Fax: +44(0)1507 601956  
[www.Jemsmoke.com](http://www.Jemsmoke.com)  
Email: [Jem@Martin.dk](mailto:Jem@Martin.dk)



**USER GUIDE AND INSTALLATION  
INSTRUCTIONS  
VERSION 1.5**



# ***Club Smoke System***

Fluids Suitable for this system:



**NOTE!** The JEM warranty will be void if any fluid other than JEM approved fluid is used. If other fluids are used there could be serious damage to the machine and the fluid may not have been tested for use in public areas.

**CONNECTIONS**

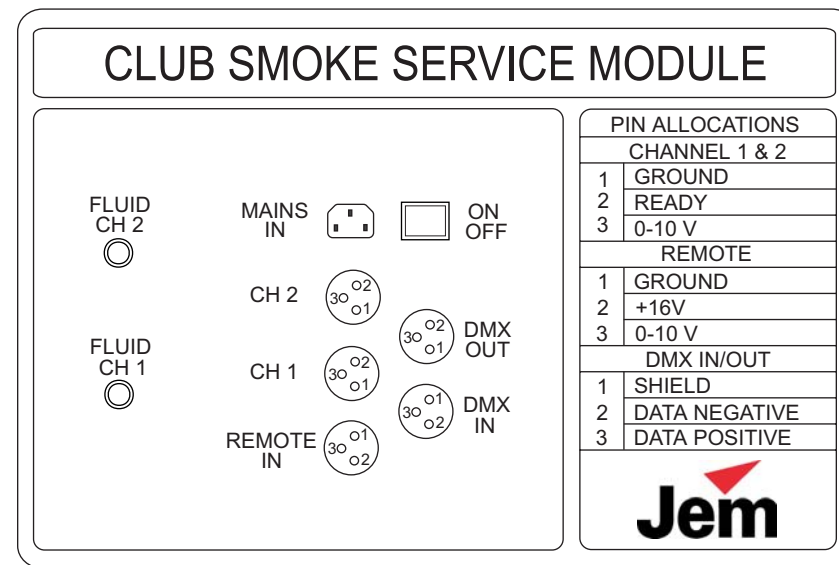
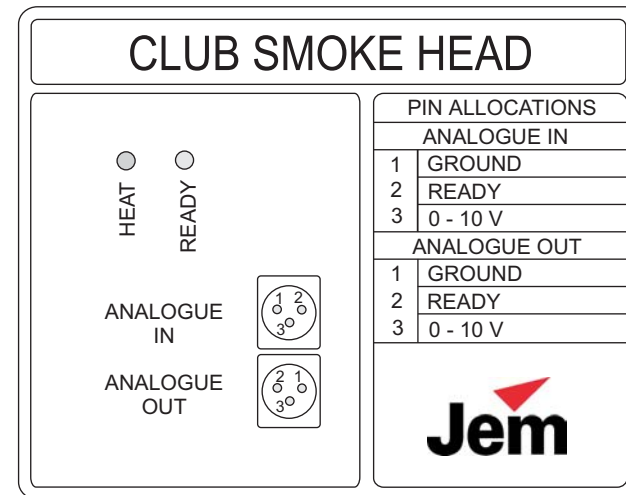

**SPECIFICATION**

HEAD

- 1KW heater
- Copper vaporizing coil
- High pressure fluid delivery
- Electronic Temperature control using thermocouple
- Analogue remote control system
- Solenoid operated flow control valve
- Adjustable mounting bracket
- Maximum distance to service module 50 m
- Maximum height above service module 10m

SERVICE MODULE

- Oscillating piston high pressure fluid pumps
- Low fluid detection by electronic sensor
- DMX512 decoder:
  - Required Channels = 1
  - Output is proportional for all levels above 10%
  - Channels supported = 1 to 512
  - Valid start codes = 0 (dimmer data only)
  - Full framing error detection implemented
- Analogue control via standard JEM Multifunction Controller.

REMOTE CONTROL

- 16v power supply from service module
- Standard 0 - 10V output signal
- Output level control from 0 to 100%
- Power On LED
- Timer cycle LED
- Timer range:

Delay time	2sec - 18 sec (x1)	16 sec - 2 min24sec(x8)
------------	--------------------	-------------------------

Run time	2sec - 18 sec (x1)	16 sec - 2 min24sec(x8)
----------	--------------------	-------------------------

**USER GUIDE CONTENTS**

- Introduction
- Features
- Safety Guidelines
- System Components
- Remote Control Operation
- DMX Operation
- System Expansion Options
- Fault Finding

**INSTALLATION INSTRUCTIONS CONTENTS**

- System Layout Guidelines
- Head Installation
- Service Module Installation
- DMX Settings
- Commissioning The System
- Maintenance
- System Expansion
- Specifications

© Martin Manufacturing (UK) PLC. 2000  
 Martin Manufacturing reserves the right to alter the specification of this product without prior notice.  
 No part of this publication shall be copied without permission from Martin Manufacturing (UK)

## INTRODUCTION

The CLUB SMOKE is a system designed for fixed installations and overcomes the problems associated with installing traditional 'Fog' machines.

Separating the fluid from the vapourising unit allows the Head to be installed in any location without the need to have access for fluid refills. The fluid is contained in the wall mountable service module which can be located away from the heads where access is easy.

The fluid level is monitored electronically and a fluid out indicator is visible at the front of the service module. This prevents damage to the pumps occurring due to lack of fluid.

The service module also contains the DMX decoder, allowing the address setting to be changed without needing access to the heads.

Installation is simple and requires no special tools, since the fluid connections are made using 'push-in' fittings and flexible nylon piping. Once installed, the system can be operated from the remote control or a standard DMX 512 compliant lighting console.

## FEATURES

Standard system includes two Heads	10L fluid container
Wall mountable Service Module	Continuous operation from up to 4 Heads
Remote control included	Electronic fluid level sensing and shutdown
0 - 10 V analogue control is possible	System expansion to 4 Heads
DMX decoder as standard	Operation can be linked with JEM AF1 fan unit
10m fluid lines and control cables	Fluid connections using 'Push-In' fittings
Service module can be located up to 50m from Heads	

## SYSTEM EXPANSION

The standard system can be expanded to operate 4 heads and the JEM AF-1 fan unit.

The additional heads are standard units and require only two additional parts to allow them to be integrated into the standard two head system. The maximum separation between two heads connected in this way is 10m. The control cable is extended using a standard XLR3 cable into the analogue out of the existing head, and the fluid line is fitted with a 'T' adaptor to provide fluid to the new head.

The AF-1 fan can be connected to the control cable by using the analogue out of the last head to connect to the analogue in of the AF-1 fan.

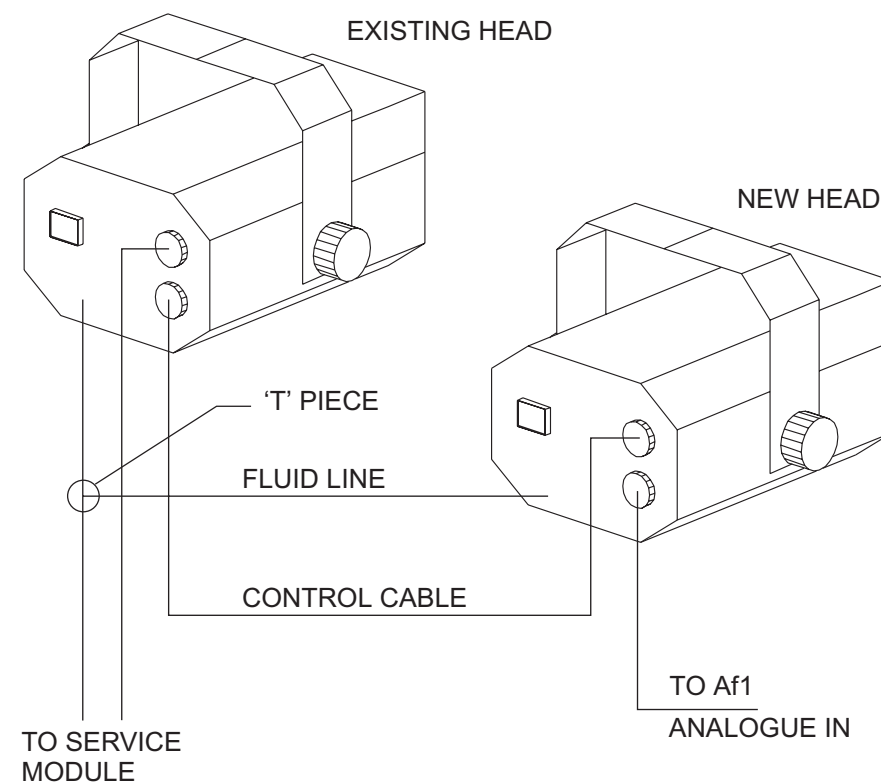

## MAINTENANCE

The system is designed for a long service life, and no regular maintenance procedures are required.

However, the following general points should be attended to.

- Clean off any fluid spilt in the service module using a damp cloth.
- Check the fluid system for damage to the nylon pipes and ensure that the pipes are all pushed fully home into the connectors.
- Only use JEM fluid in the system for best results.
- Keep the ventilation slots of the heads free of dust.

## SAFETY GUIDELINES

Always use a JEM approved fluid, other fluids could be dangerous and could cause damage to the machine.

Check the voltage is correct for use with the machine, the voltage setting is printed on the serial label.

Always read the user guide before operating the machine, smoke machines need to be operated carefully to avoid risk.

Do not remove the cover or attempt to repair a faulty machine, an authorized JEM dealer should be contacted in the event of a faulty machine.

Always use smoke machines in well ventilated areas, over use could affect sufferers of asthma or other chest conditions.

Do not use the machine if there is a faulty mains lead or plug this could be dangerous.

Do not spill fluid over the machine, if fluid is spilt clean with a damp cloth and contact an approved JEM dealer for advice.

Never touch the nozzle at the front of the machine; the nozzle can stay hot for up to 10 hours

### Mains Lead Wiring Instructions

Brown = Live  
Blue = Neutral  
Green / Yellow = Earth

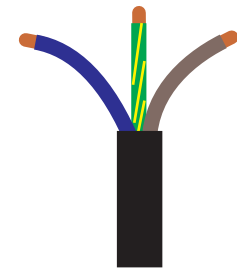

Note! This Appliance must be earthed

**SYSTEM COMPONENTS**

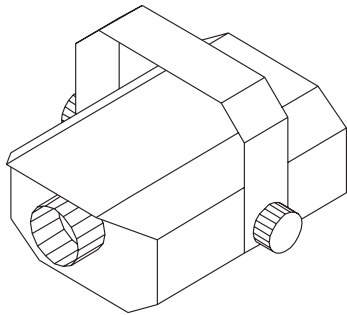

**HEAD 1**

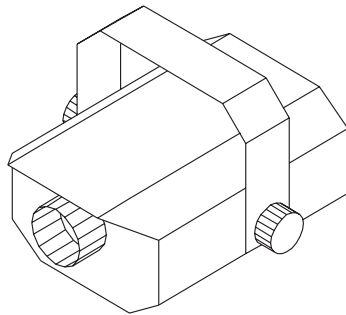

**HEAD 2**

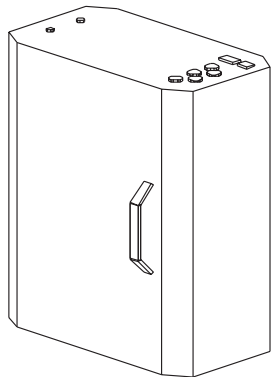

**SERVICE MODULE**

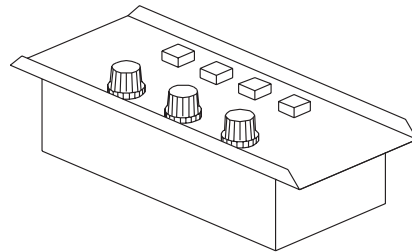

**REMOTE CONTROL**

**COMMISSIONING THE SYSTEM**

This section assumes that the remote control has been fitted to the system.

Power up all parts of the system, and fit a 10 liter bottle of JEM fluid to the service module. Ensure that the fluid pipes are below the fluid level and wait for the low fluid LED on the front of the service module to go out. (no longer than 1 minute).

On the remote control, set the 'STAND-BY' button to ON. This will switch on the heaters in the heads, which will generally require 15 minutes to reach operating temperature. The LEDs on the rear panels of the heads show the status of the heating cycle. When the green LED is on, the head is ready to make smoke.

If the remote is not fitted, the heaters in the heads must be switched on by setting a valid DMX address on the unit and transmitting DMX data with a value of < 10%.

When the heads are at operating temperature, the system can be primed with fluid.

Set the OUTPUT control to maximum, and hold down the FOG button. The pumps will prime, and then the fluid will go to the heads. Check for leaks at this stage in the installation.

When the fluid reaches the heads, smoke will be produced. The heads can now be adjusted to give the required coverage.

### DMX SETTINGS

To operate the system on DMX, simply connect the DMX data cable into the DMX IN connector and either continue the link using the DMX OUT connector, or fit a terminating plug.

The DMX address setting is made using the DIP switch mounted inside the fluid compartment of the service module.

The DIP switches use the standard binary weighting system.

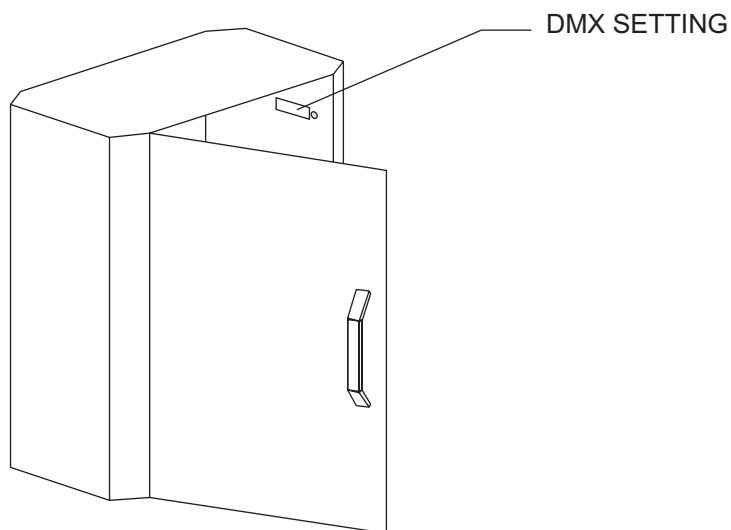
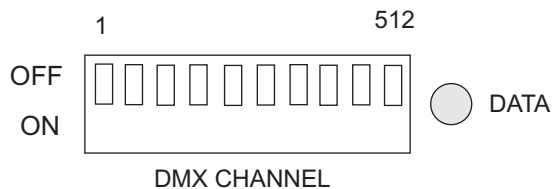

### REMOTE CONTROL OPERATION

The remote control allows the user to control the following parameters:

- Fog output level
- Automatic operation using the timer functions
- Switching the heaters in the Heads to standby (no power used)

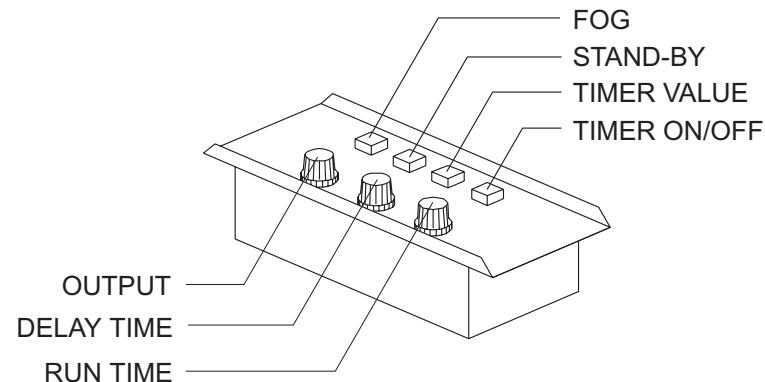

**FOG BUTTON:** Fires the heads when they are up to temperature.

**STAND-BY BUTTON:** Turns the Head heaters ON and OFF.

**TIMER VALUE BUTTON:** Multiplies the operate and delay times by a factor of 8 when selected.

**TIMER ENGAGE:** Engages the timer to fire the Heads according to the present settings.

**OUTPUT CONTROL:** Sets the output level of the Heads.

**DELAY TIME CONTROL:** Controls the OFF time when the timer is running.

**RUN TIME CONTROL:** Controls the ON time when the timer is running.

**POWER LED:** This LED will be lit when the machine is switched on.

**CYCLE LED:** This LED will be lit when the timer is engaged and the Heads are operating.

## DMX OPERATION

The system may be operated using the industry standard DMX 512 digital control protocol. This allows the control of the fog system to be easily integrated with the lighting system in most installations.

DMX may be used without disconnecting the remote control, although the timer should be switched off to prevent the remote from overriding the DMX level setting.

The system implements true proportional control of the fog output rather than the simple switching functions found on other equipment. See the system specifications for the DMX protocol, and the installation instructions for the DMX channel settings.

The heaters in the Heads will switch on when the DMX receiver detects valid data on the link; a channel other than 0 must be set on the address DIP switches.

To switch off the heaters, simply switch off the DMX transmitter.

When operating from a traditional desk with faders, a 10% dead-band is implemented at the low end of the output range. Within this range, the output from the heads is zero.

The system uses a 'pump ramping' technique to allow continuous operation. This means that transmitting DMX 100% will cause the machine to run at full output until the temperature falls and the output is automatically reduced. The output will remain at this level until the DMX signal is reduced, or the fluid is exhausted. There is no possibility of damage, since the electronic fluid level sensor will shut the system down.

## SERVICE MODULE INSTALLATION

The service module is wall mountable via the mounting bracket provided, although the unit can equally be used floor standing.

To fix the unit to the wall, remove the bracket from the unit and fix to the wall using 2 x M6 Rawl bolts (or equivalent). Remember to allow enough clearance above the unit for the cable connections.

If you want to be able to remove the side panels for service purposes, allow 15cm clear space to either side.

Once the bracket is fitted securely to the wall, the unit can be hooked on and the retaining bolts (2 x M6) fitted.

The functions of the service module connectors are shown on the top panel, and also in the specifications at the end of this guide.

Connect the control cables to the two heads into the female XLR3 connectors marked Ch1 and Ch2.

The remote control (if required) is connected into the male socket marked REMOTE. The fluid lines are connected to the two 'push-in' connectors marked Ch1 and Ch2.

DMX connections are made via the two XLR3 connectors marked DMX IN and DMX OUT.

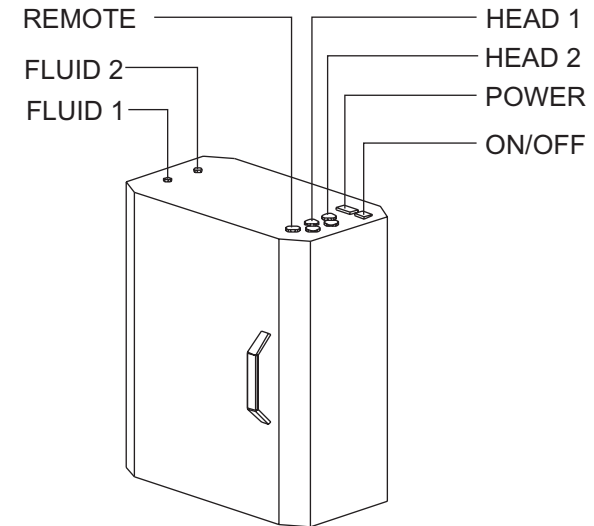



## HEAD INSTALLATION

Once the ideal location for the head has been determined, the unit can be fixed into position and connected to the service module.

The rear panel of the head has two XLR3 connectors and one IEC connector. The pin functions are shown on the rear panel and in the specifications in this guide.

Using the cables supplied with the system, connect the mains power into the IEC connector and the control cable into the XLR3 male connector. The fluid line must be cut to a clean end, and then pushed home into the 'push-in' fitting on the back panel.

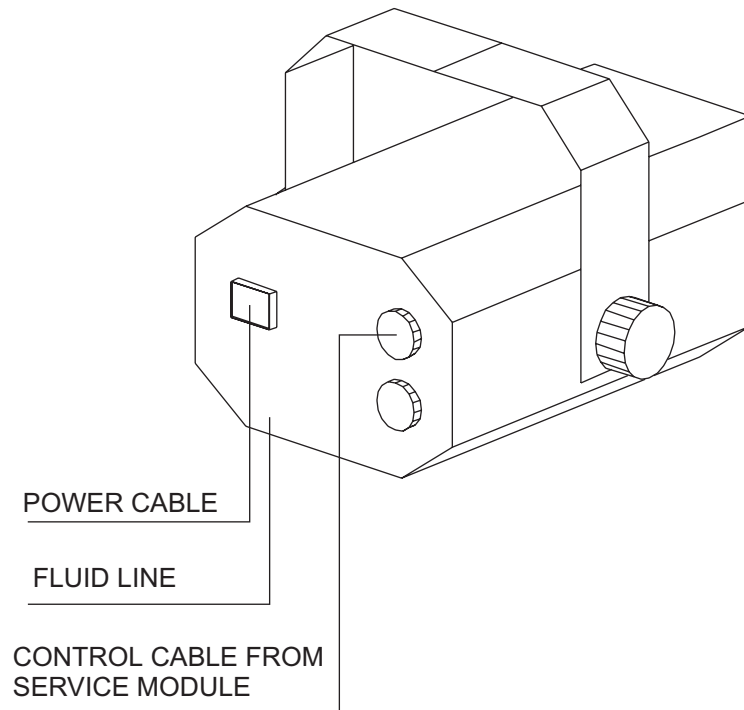

## SYSTEM EXPANSION OPTIONS

Although the standard system is supplied with two Heads, it is possible to expand this to 4 Heads in total.

Adding the extra heads is simple and requires no alterations to the rest of the system.

It is also possible to link the JEM AF1 fan unit to the system using the analogue link input on the fan. This allows the fan to be 'fired' with the Heads to give wide smoke dispersion.

The installation instructions show how to add additional components to the system.

**FAULT FINDING**

This fault finding guide assumes that the system has already been successfully installed and operational. If you have problems at the installation stage, consult your local JEM agent for advice

SYMPTOM	CAUSE	CURE
No fog output when using the remote control to fire the heads	Heads are not ready	Allow time to reheat
	Fluid is below min level	Add fluid
	Standby button is OFF	Set standby to ON
No fog output when using DMX to fire the heads	Incorrect DMX address	Check settings
	Heads are not ready	Allow time with DMX on
	No DMX termination	Fit 120 ohm resistor
Fluid out LED is lit on the service module	Fluid level is below min	Add more fluid
One or both heads is not ready after 15 minutes heating time	Faulty control cable	Check cable
	Blown fuse in head	Return to dealer to repair fault
Fog disperses too quickly	Wrong grade of fluid used for the application	Choose a longer lasting fluid (see front cover)

**SYSTEM LAYOUT GUIDELINES**

Before beginning the installation, turn to page 4 of the user guide to see the components that make up the complete system. This is the standard system, expansions will be dealt with later in the guide.

For detailed instructions on installing each part of the system, refer to the sections covering each module.

Start the installation by making a sketch of the site in order that cable and fluid line runs can be optimized. Remember that you must allow for the height of the heads as well as the distance across the floor space.

The maximum distances and heights can be found in the system specification at the end of this guide.

When locating the heads, take account of any movement that may occur when parts of the lighting rig move. This will require a loop of free cable and pipe to be added into the installation. Avoid this type of installation if possible.

Avoid locating the heads over public areas

Allow for maintenance access to all parts of the system to make fault finding and system expansion easier.

Attempt to evaluate the way the effect will disperse in the venue before permanently fixing the heads into position.

Route the fluid lines from the service module to the heads using smooth bends to reduce the possibility of the pipe collapsing when forced into a tight bend.