

User's Manual

PROFESSIONAL MP3 DJ SYSTEM

RC V3
RCP-100I
RCP-200I-A
RCP-200I-B
BPM Studio 4 Pro





Content

Introduction	1	1.01. About this manual	8
		1.02. System requirements	8
		1.03. Package contents	9
The installation of software and of remote control units	2	2.01. Software installation	9
		2.02. Connection of remote control units	12
		2.03. Hardware reset	12
		2.04. The First Program Start	13
		2.05. Defining Remote Control Unit Parameters	13
		2.06. Defining Driver and Audio Parameters	14
Description of the program	3	3.01. The Program Window of BPM Studio	16
		3.02. Player	17
		3.02.1. Basic Functions	17
		3.02.2. Working with DirectCue keys	18
		3.02.3. Pitch and Master Tempo	18
		3.02.4. Fine Adjustment of Sliders	19
		3.02.5. Realtime BPM Counter	19
		3.02.6. The Player Window	20
		3.03. Playlist	21
		3.03.1. Basic Functions	21
		3.03.2. Waitlist, Single List Mode	22
		3.03.3. Adjustable Column Width and Content	23
		3.04. Preview Player	14
		3.05. File- and Playlist archive	22
		3.05.1. File Archive	24
		3.05.2. Playlist Archive	26
		3.05.3. Playlist History Function	26
		3.05.4. Adjustable Column Width and Content	27
		3.05.5. Sorting Order	27
		3.06. Loop Sampler	28
		3.06.1. Using the Loop Sampler	28
		3.06.2. The Loop Sampler display	29
		3.07. Sample Player	29
		3.07.1. Editing Samples, and Assigning to keys	30



Content

Description of the program	3	3.08. Sample Editor	31
		3.08.1. Sample Block functions	31
		3.08.2. Sample Channel functions	31
		3.09. Cross Fader	33
		3.10. BPM Counter	34
		3.10.1. Monitor Player of BPM Counter	34
		3.10.2. BPM determining in manual mode	35
		3.10.3. BPM determining in automatic mode	35
		3.11. File Editor	36
		3.11.1. Loading and displaying a title	36
		3.11.2. Adjusting display range	36
		3.11.3. Marking ranges, and exporting into files	37
		3.11.4. Adjusting volume and pitch	37
		3.11.5. The Toolbar	37
		3.11.6. Functions of different markers	37
		3.11.7. Working with Cue Points	38
		3.12. File Info Box	39
		3.13. Mixer	40
		3.13.1. Audio channels	40
		3.13.2. The Equalizer	41
		3.13.3. Loading and storing equalizer settings	41
		3.13.4. Recoder	42
		3.13.5. Compressor/Limiter (AGC)	43
		3.14. MP3 Stream Modul	46
		3.15. CD-Player / CD Writer	48
		3.15.1. CD-Reader	48
		3.15.2. Encoding Audio-CDs	48
		3.15.3. CDDb-Query	49
		3.15.4. Copying Audio CDs (Ripping)	49
		3.15.5. "CD at once" Mode of the CD Player	50
		3.15.6. Encoder	50
		3.15.7. CD-Writer	51
		3.15.8. Creating Audio-CDs	52
		3.15.9. Creating Daten-CDs	53
		3.15.10. System test in test mode	54
		3.15.11. Deleting CD-RW's	54



Content

Description of the program	3		
		3.16. BPM Print Designer	55
		3.16.1. Starting BPM Print Designer	55
		3.16.2. Export list window	56
		3.16.3. Print preview window	58
		3.17. BPM Studio Server Components	60
		3.18. BPM Studio File Formats	61
		3.19. Program Options	62
		3.19.1. Presets	62
		3.19.2. Options	63
		3.19.3. Audio I/O	65
		3.19.4. Storing	67
		3.19.5. CDDA-Copy	68
		3.19.6. CD-Writer	70
		3.19.7. Remote Control	73
		3.19.8. User Administration	75
		3.19.9. Server components	76
		3.20. Additional Functions	77
		3.20.1. Normalize Function	77
		3.20.2. Suchen Dialog	77
		3.20.3. Monitor Functions	77
		3.20.4. The BPM Database	78
		3.20.5. The PreAmp Function (Limiter)	78
		3.20.6. The Backup- and Update Functions	78
		3.20.7. Interface for Visualisation Plugins	78
		3.21. User Administration	79
		3.21.1. In General	79
		3.21.2. User specific settings	79
		3.21.3. Example Configurations	81
		3.22. Network Functions	82
		3.22.1. Addressing MP3 files	82
		3.22.2. Network File Archives	83
		3.22.3. Example Configuration	85



Content

First Steps with BPM Studio Software	4	4.01. Where can I get MP3 files?	86
		4.02. How can I play MP3 files?	86
		4.03. Beat-Matching with BPM Studio	87
		4.04. How do I work with Playlists?	89
		4.04.1. Adding titles to a Playlist	89
		4.04.2. Modifying the title order	89
		4.04.3. Storing a Playlist	90
		4.04.4. Loading a Playlist from hard drive	90
		4.04.5. Drag&Drop functionality of Playlists	90
		4.04.6. Adding a Playlist to the Archive	90
		4.04.7. Loading a Playlist from the Archive into a player	91
		4.04.8. Merging a Playlist to an already loaded list ..	91
		4.04.9. Adding title sequences of a Playlist to an already loaded list	91
		4.04.10. Screening titles	91
4.05. Creating Fades between titles	92		
4.06. How can I change title information?	94		
4.07. Ripping and Archiving of Audio-CDs	95		
4.08. How do I use the Sampler most efficient?	98		
4.08.1. Single Play	98		
4.08.2. Scratch Mode	99		
4.08.3. Configuring the Sample Player	99		
ALCATech RC Units:			
Remote Control RC V3	5	5.01. RC V3 view	100
		5.02. RC V3 description	101
		5.03. RC V3 and fader start	104
Remote Control RCP-1001	6	6.01. RCP-1001 view	106
		6.02. RCP-1001 description	107
		6.03. RCP-1001 and fader start	112
Remote Control RCP-2001 A+B8	7	7.01. RCP-2001-A front view	113
		7.02. RCP-2001-B front view	114
		7.03. RCP-2001 reverse view	114



Content

Professional work with the Remote Control RCP-2001	8	7.04.	RCP-2001 description	115
		7.05.	RCP-2001 and fader start	122
		8.01. Working with Loop Player	124	
		8.01.1. Recording and reproduction of the loop	124	
		8.01.2. Recording using AutoLoop function	125	
		8.01.3. Loop storing	126	
		8.01.4. Loop storing by a DirectCue key	126	
		8.01.5. Loop storing by a Sample Player key	126	
		8.01.6. Deleting of the Loop Player	126	
		8.01.7. Editing a Loop	127	
		8.01.8. Beat-Stepping	127	
		8.02. Working with DirectCue buttons	130	
		8.02.1. Define a standard Cue-Point	130	
		8.02.2. Editing of a Cue-Point	130	
	8.02.3. Beat-Stepping	131		
	8.02.4. Storing of a Cue-Point by a DirectCue key ...	131		
	8.02.5. Setting DirectCue Points on-the-fly	132		
	8.02.6. Editing of DirectCue Points	132		
	8.02.7. Deleting of DirectCue Points	132		
	8.02.8. Deleting of all DirectCue Points and the Loop Player	132		
	8.03. Beat-Stepping	133		
Appendix	9	9.01.	Keyboard use	134
		9.02.	Tips and instructions	136
		9.03.	Support, Kontakt	137
		9.04.	Glossary	138



Congratulations to your purchase of BPM Studio!

With BPM Studio software and control units from ALCATech, you have exceptional systems for audio editing and administration at your disposition. With your purchase, you have chosen to follow a completely new way in multimedia applications. BPM studio is a next generation audio-player, providing all new ways of playing, editing, and archiving audio files. These systems have been developed explicitly for dance clubs and DJs, although, due to their wide spectrum of features, they are utilized in many other areas as well. Currently BPM Studio is the only software on the market, capable of playing and archiving different audio file formats to the extend it does. An unparalleled feature is the opportunity to conveniently control the system with 19" rack mount control units. An experienced Team of DJs has tested this software in professional use, while still in it's development phase. It is subject to frequent quality control, and improvement. A modern design, ergonomic user interface, and the remote control units allow for save handling even under most difficult circumstances. You will be surprised about the many new opportunities BPM Studio will offer you, regardless if you are an entry-level user or a professional. To ensure that you will be able to take advantage of the programs extensive features, and work effectively with it, it is highly recommended that you thoroughly study this manual. BPM Studio is available as professional level MP-3 DJ software, supporting remote control operation by one or more 19" controllers. Different controllers are available, distinguishing themselves by different numbers of available features, and price. You can determine the version you have purchased, by checking the sticker on your box. Also available in this product family is BPM Studio Gastro, (a six fold MP-3 player, capable of serving audio output to six independent areas of a building) and a personal edition. More information about this product is available on our web page, or at your nearest retail store.

1.01. About this Manual

The BPM Studio Manual provides detailed information about operating soft- and hardware. It is intended to help you with your initial phase of working with this system, and to provide answers to frequently asked questions. It is recommended to install the software before studying this manual. To do so, follow the instructions in the following chapter. Also, this chapter covers system requirements, and delivered supply. This manual requires you to be familiar with your operating systems major functions and conventions, as well as knowing how to use your mouse. **Bold and underlined terms** are covered more extensively at another part of the manual. This part of the manual covers functions of different control units. Please be aware that not all functions are available at all control units.

1.02. System Requirement

To use BPM Studio you need the following

- IBM compatible Pentium® PC at least III-700
- 128 MB RAM (better are 512 MB)
- 20 MB available hard drive space for program files
- SVGA graphics adapter with a minimum resolution of 1024x768
- 16 Bit sound card (better a professional multichannel sound card)
- 40x CD-ROM Drive
- Windows® 98, Windows® ME, Windows® 2000 or Windows® XP
- Parallel port LPT1 or USB Port for dongle
- Serial port COM 1 or 2
(if an ALCATech RC unit is used)



1.03. Supply

Please make sure that following parts are present:

1. BPM Studio Pro CD
2. Dongle (Hardware Copy Protection for printer port LPT1 (or USB Port, optionally))
3. Manual
4. Registering post card
5. RC unit with, depending on box sticker, with
 - Power supply unit
 - serial cable

2.1. Software Installation

This program needs to be installed to your hard drive from your CD. It can not be executed directly from CD. Whenever working with BPM Studio, the supplied dongle needs to be installed to your computers printer port LPT1 (or USB Port)



If you are installing an upgrade to version 4, you must install into the original directory, if you want to further use the file archive and user administration settings. Please refer to paragraph 10 of this chapter.

1.) Plug the supplied dongle into the printer port LPT1 (or USB Port) of your PC. (If you have already installed a printer on this port, simply link your dongle between printer cable and your PC's printer port.)

2.) If you have purchased BPM Studio together with a 19" control unit, connect it to a serial port, (COM1, COM2), using the supplied serial cable. Also connect your unit with the power supply unit to a wall outlet. Read also 2.2., Connecting the control unit

3.) Insert your installation CD into your CD-ROM drive.

4.) If your PC has auto notify enabled, the installation program will now be started. If this isn't the case, choose run in your Windows start menu, and enter: "D:\setup", D representing your CD-ROM drives drive letter.

5.) Now the setup for the main application, additional modules, and the online manuals will start.



Choose install BPM Studio to start the installation.

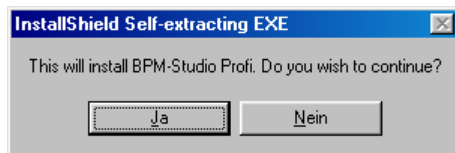

6.) Clicking [YES] will confirm the installation. You can still abort at this point. If you confirm, installation files will be copied to your hard drive.

7.) Now setup will prompt you to ensure that no other applications are running during the installation process. At this point too, you still have the option to abort the installation, by clicking on [CANCEL]

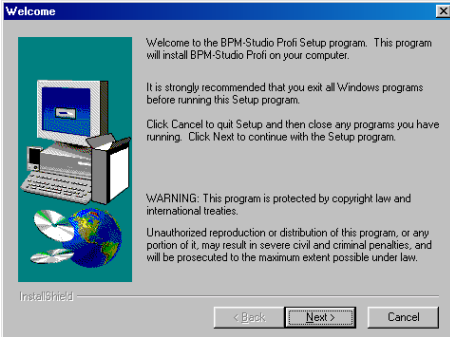

8.) If you proceed by clicking [next], setup will display the ALCATech end user license agreement

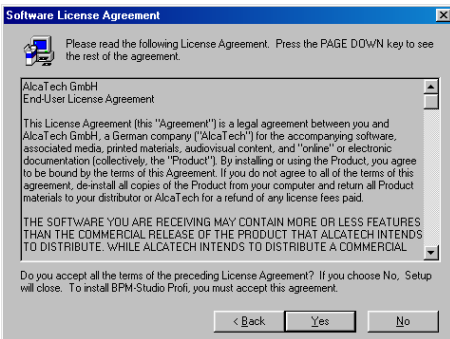

Please read it carefully and only continue the installation process if you agree to adhere to the license terms. Confirm you agree with the license agreement by clicking the [YES] button.

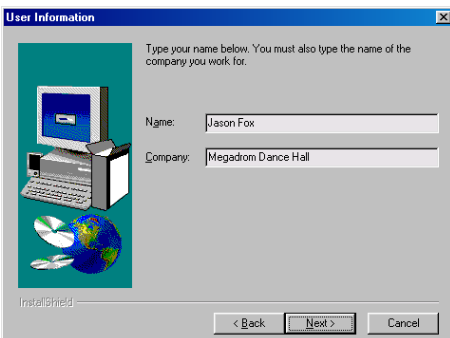

9.) At this point register your version of Dongle Server Tools to your name by entering your first and last name and, if applicable, your companies name. Click [NEXT] to confirm.

10.) Now, optionally, you can specify a path for the program files, other than the default. It is recommended though to use the default path, since this simplifies possible support questions later on. The path to the default directory is: c:\program files\alcatech\BMP Studio Pro.

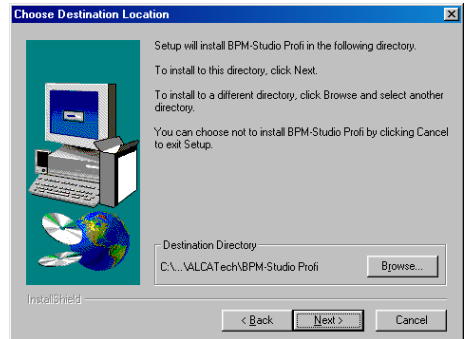

If you install an upgrade from BPM Studio light, or Home, and you want to keep using your file archive and user administration settings, you have to install the upgrade into the old directory. If this is the case, specify the path by using the [BROWSE] button. (e.g. C:\program files\alcatech\BPM Studio Home).

If you are not sure where these files are located, you can determine the path the working directory by right clicking on the BMP Studio icon on your desktop, and choosing "properties". The field TARGET indicates the location of these files. By clicking [NEXT] you can proceed to the next step.

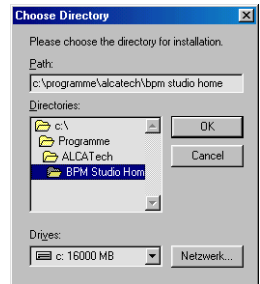



11.) The following dialog box confirms that new entries have been created into the Windows start menu for BPM Studio LE, and other useful links.

13.) Upon completing this process, according entries will be added to your Windows registry, and program shortcuts will be created in the start menu:

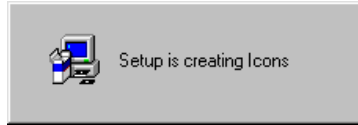

Please be patient at this point, since this may take a little while

Of course you have the option to use another, already existing group, or to rename this entry. You can always go back by clicking the [BACK] button.

14.) In order to complete and apply changes made to your system, a Windows restart is now required. You also have the option to cancel and restart the system later, this is not recommended though.

12.) The unpacked program files will now be copied to your hard drive, according to the previously defined parameters. Throughout this process you will continuously be informed about installation progress, and remaining storage capacity of your hard drive

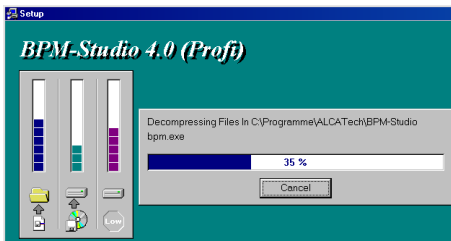
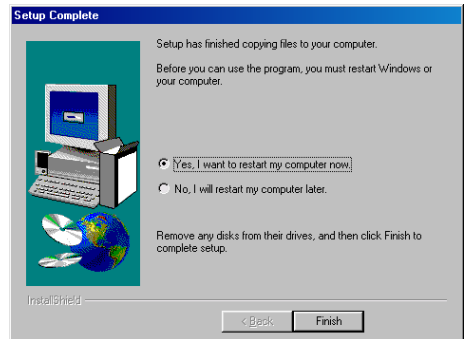

After a system reboot several shortcuts will be added to the windows start menu.

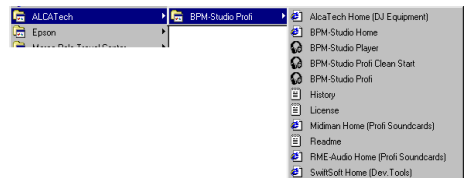

Also, a BPM Studio icon has been created on the desktop. Now you can start BPM Studio for the first time.





2.02. Connecting the Remote Control Unit

1.) Connect the control unit [38] to a free serial port of your PC (e.g. COM2) using the supplied cable. You may also use a different cable, as long as the length does not exceed a maximum of 15 meters (45 ft.). It is recommended to use cables not longer than 10 meters. (30 ft.)

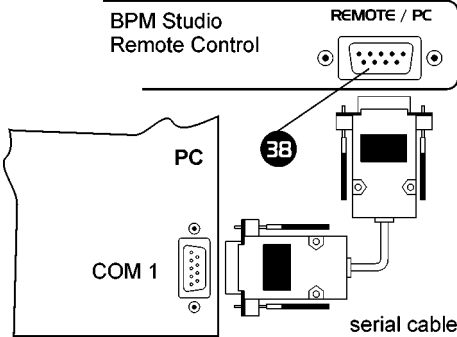

2.) Connect the supplied power supply unit [39] with the control unit, and plug it in to a power outlet.

The connection of the Remote Control is also possible by USB Port. Therefore a special USB-serial adapter is available by ALCAtech.

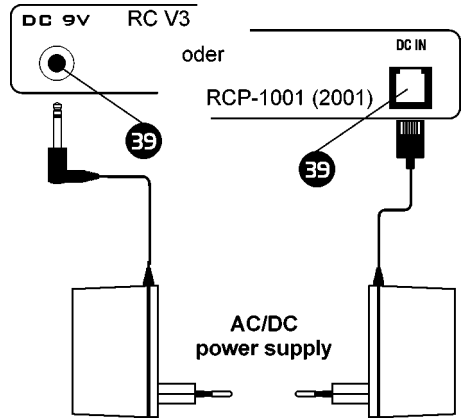

2.03. Hardware Reset

Control units RCV-1001 and RCP-2001 come with own integrated processors and firmware. Should stable operation ever be disrupted by external influence, the control unit can be restarted by pushing the reset button. If the software is running, it will automatically detect if the control unit has proceeded it's internal boot process, and resume normal operation. To reset, push in sequence the track-selector and cue key of player A and B. Upon pushing the last key (cue key of player B) the unit will reset, and reboot. After completed system boot, the display will show a message stating that the unit is working again.

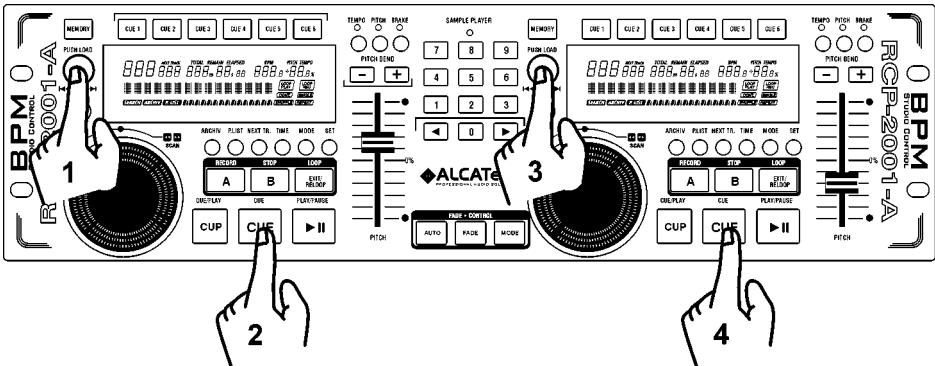



2.04. The First Program Start



Double click the program icon on the desktop or, from your windows start menu choose: programs -> ALCATech -> BPM Studio. The program will now start, and ask if you want the small player to be default player for MP-3 files. If you do not want the player to be your default program for such files, click no. You can also prevent this dialog from showing at the next program start, by checking the “don't ask me again” check box.



Upon this, the program will search for all local MP-3 files on your system, The search result will be shown in the “HARD DRIVE” group in **File Archive**.



Now the PC's serial ports defined in the program options will be scanned for ALCATech remote control units. If one is found, the program will announce so. Now you can start your work.

Read our step-by-step instructions how to get familiar with the hard- and software, and how to create file and play lists.

2.05. Defining Remote Control Unit Parameters

BPM Studio remote control units allow for variable, individual settings. Thus, for example, the pitch slider can be used either to adjust the pitch value or, alternatively as the player's volume control. To adjust such settings, choose “options” in the players pop up menu (Right click into the play list area), and click on the control unit tab.

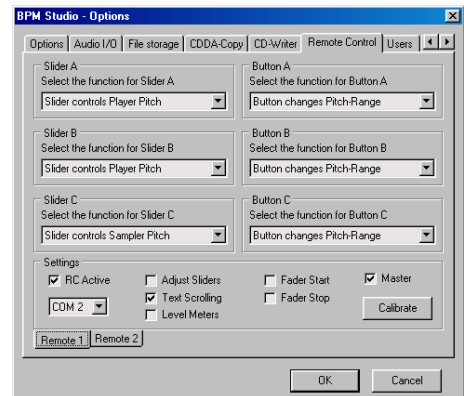
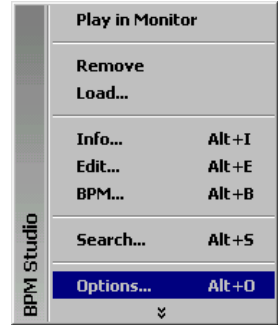

In this tab you can, depending on your control unit model, make different adjustments, and modifications. Please refer to detail descriptions, ALCATech remote control units, from chapter 6 on later in this manual, for this. Also refer to program options, chapter 3.7.



2.06. Defining Driver and Audio parameters

BPM studio offers extensive features, and therefore requires more system resources than simpler MP-3 players like WinAMP™ for example. The capability of playing 10 MP-3 files simultaneously, or various channel signal output for example, demand a well configured PC. Further BPM Studio offers extensive possibilities to manipulate audio engine settings. The audio engine represents the core of BPM Studio, and is responsible for highest quality play backs with shortest possible remote control latency intervals.

Therefore make sure of the following:

- 1.) Every sound card in your system must have it's own, assigned IRQ. This interrupt can not be shared with other system components.
- 2.) Also the serial port used to connect the remote control unit must have it's own, unshared interrupt.
- 3.) Background programs, like real time virus scanners, power- and print management, etc. should be deactivated.
- 4.) For utmost compatibility to various different sound cards, BPM Studio provides various different driver models:

Kernel driver: 4..13ms, this driver is definitely the fastest

Direct Sound driver: 20..30ms, when emulating drivers up to150..300ms (!)

MME Wave driver: 70..180ms, depending on buffer size, and program chosen options

ASIO/EASI driver: 20..50ms, latency is usually defined manually in the ASIO drivers program options

This suggests to prefer the Kernel, or Direct Sound driver, since both work on the kernel level of the operating system, and therefore operate rather independent from the systems user resource. The ASIO, and Wave drivers also work rather stable, and are especially suitable for background music, like in dance schools, restaurants, etc. BPM Studio supports Wave drivers, since they are available for almost any sound card, and usually provide smooth operation. Normally they are also deployable under Windows NT.

Direct Sound Driver:

This is the fastest and most stable common driver. Depending on hardware outfit, it allows switching from Cue to Play within 20 to 30ms. For the demanding DJ, who is very conscious about mixing on single-beat level accuracy, utilizing the Cue/Play- and loop functions to accomplish this, this driver is essential. Although, if your sound card is compatible with the kernel driver, it should be preferred, since it has even shorter latency intervals while still maintaining stability.

Kernel Driver:

This device driver, developed by ALCATech, addresses the sound card on a very low kernel mode level. Due to the very high priority kernel drivers have within the system, they provide shortest latency intervals from 4..13ms, while still maintaining system stability. The kernel driver utilizes common driver functionalities like direct sound for example, and therefore supports many different cards, even models that, for the reason of unavailable direct sound drivers, had to be used with ASIO wave drivers, and therefore tended to produce drop outs.

Ex version 4.2 the Kernel driver is also able to operate under Windows® 2000 and Windows® XP. So, this operating systems can be used as full multimedia systems, too.



Especially the new DirectCue, and loop functions require minimal latency intervals, and fastest reaction times. Therefore you should try to keep latency and buffer size to a minimum.



ASIO Driver:

This driver developed by Steinberg, serves as interface for many multi channel sound cards. It is usually a bit slower than direct sound driver, and, in user mode, tends to drop out, if system resources are low. For the most practical operations, where background music is the only objective, they work sufficiently well and stable though. Usually latency is anywhere between 6 and 50ms, and can usually be adjusted in the driver options. To avert drop outs when using BPM Studio, latency should be set to 20..46ms. The best value is usually determined by trying out. Some tested cards have been reported to operate unstable, when used with this driver.

EASI driver:

This drivers, developed by Ematic, performance in regards of stability, and functionality equals the ASIO drivers. As a matter of fact, it was developed as Ematics answer to Steinberg's ASIO. All statements made about the ASIO, can be applied to the EASI as well, since these two drivers hardly differ at all, although the Ematic driver is only sporadically supported, and therefore is of almost no importance.

Wave driver (wave out):

This is a very stable driver that can be used instead of direct sound drivers, although it has higher latency times. On multi channel cards not supporting direct sound, or ASIO drivers, this is the only possibility though, to address different channels separately. This driver is well suitable for background music, but hardly for live DJs at all. Latency times are located between 120 and 200ms.

Select the driver most suitable for your needs res. available for your sound card in BPM Studio. If you should encounter difficulties in using BPM Studio, change the driver type.

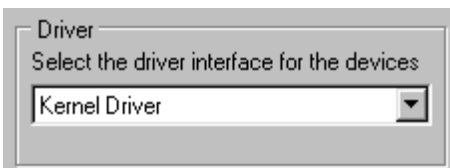

All important audio engine, and sound driver settings are defined on the "Audio IO" tab, located in the **program options**.

Read in the according chapter 3.7. How to adjust BPM Studio's sound card utilization to fit your needs.

Should you encounter problems playing titles with BPM Studio try at first to change the following parameters.



Size of BPM Studio's internal buffer. Change this value if you occasionally experience dropouts when playing titles, or the players don't start right.



Size of the drivers buffer. Change this value if you can not achieve clean audio playback. (This value can only be edited when using wave drivers.

Lowest Latency

BPM Studio operates with smallest buffer sizes, and latency times. Deactivate this check box if you experience difficulties with your sound card.

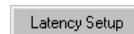

This option enables you to manually enter the latency interval of your driver. If necessary increase this value until you achieve clean playback.



To use BPM Studio's monitor functions, you have to perform a sound card test. Further information about this can be found in the according chapter: Monitor functions.



3.01. The Program Window of BPM Studio



The program window contains following modules:

Player A

Player B

Play list for player A

Play list for player B

Sample Player

BPM File Archive

The lower and center areas (play list, and file archive) are multi functional.

The center area, containing both play lists, can be switched to single play list, or wait list view.

The lower area displays optionally either file archive, mixer, or CD-player/ripper. Read the referring sections on how to switch to the according sub modules.

The following chapter covers structure, and functionality of these modules in detail. To quickly get into working with BPM Studio, we recommend the step-by-step instructions in chapter 4.



The appearance of the program window can be changed completely. (Skin support) In program options (Chapter 3.18.), choose a skin you like. On the ALCATech website, (www.alcatech.com) a "design-pack" with tools and hints for your own skin creation is available for download.



3.02. Player



If a title has been ripped using the CD-at-once feature, Chapter 3.15.5, you can navigate with the right mouse button, and the track keys within this title.

3.2.1. Basic Functions

The player controls playback of audio files and one or more CD-ROM drives, if audio CDs are inserted. Besides the functions of an analog CD players, a vast number of additional features is available, which are only achievable by utilizing a PC. Structure and ergonomic design allow for professional use, and make readjusting from commercial double-CD-players easy.

All titles can easily be inserted and played from a **play list**, or a **BPM file archive** by drag&drop. Also simply double clicking on it in the according play list, can load, and start playing a title. Further, it is possible to start a title from your hard drive over the pop up menu.

Also at the remote control unit (only RCP 1001 and 2001), by using the track selector button, titles can be selected and started.

Track Keys:



Jumps to the beginning of the title. If title has played less than two seconds, jumps to previous title.



Jumps to the next title in the play list.



Position slider.

Loop/Search keys:



Left mouse button: Player will go into loop mode, if mouse button remains pressed, search speed will continuously be increased.

Right mouse button: Player will go into loop mode, if mouse button remains pressed, player will continue search at constant speed. If the search keys are used with the right mouse button during regular play mode, they behave like common fast forward and fast back keys.

Play mode (switch):



Single play stops the player at the end of the current title, otherwise the next title will be started immediately.



Loop, repeats current title indefinitely



Shuffle, plays titles in random order



Tempo, switches between pitch and master speed

Main functions:

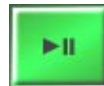

Play / Pause: When switching from pause to play, the main cue-point will be newly set. When the player is running, pressing the right mouse button will slow it down, if the player is stopped, right clicking will accelerate it. (BRAKE function.)



Stops the player, and repositions to current cue point. When holding this button for 2 sec., it can reposition either to current cue point, or title start.



Plays title from last cue point on.



Optionally, the alternative cue point function can be activated in the program options. This will cause the player to play as long as the CUP key remains held. Upon releasing it, the player will reposition back to the cue point.

3.02.2. Working with DirectCue buttons

DirectCue buttons offer the ability to start a title from up to 6 cue point positions on, by pressing a button. The cue points can optionally be placed on the player display via the pop up menu. A light blue dot, indicates that a cue point has been assigned to a particular button.



An orange dot indicates the cue point currently loaded into the player.

To save any given position within a title as cue point, click on the M icon in the display, and subsequent click a cue point button, to assign the marked position to it. With the X icon, cue points can be deleted, using the same procedure. You'll find a detailed description in chapter 4. First Steps.

3.02.3 Pitch, and Master Speed

With these two functions the playback speed of a title is manipulated, and subsequently, the BPM value. Pitch function, contrary to master speed also raises the audio frequency. These two functions are used for title speed adjustment when mixing. The **universal buttons** **A**, **B** and **C**, can be programmed for different variation ranges. Assigned by default are:



Pitch:

A: +/- 8%, B: +/- 16%, and C: +/- 24%

Master Tempo:

A: +/- 4%, B: +/- 8%, and C: +/- 12%



Switches pitch function on or of for this particular player



Pitch Bend, decreases speed continuously



Pitch Bend increases speed continuously



BPM Match, assumes the BPM value of the other player



with right muse button:
Title will be faded out, and if single play option is off, the next title in **play list** will start.



DirectCue points will not be loaded, when in auto-fade mode. Please DO NOT use this mode if you want to use stored DirectCues.

3.02.4. Fine Adjustment of Sliders

When you click on the scale beside a slider, the pitch range will be changed continuously in 0.1% increments. Thus, depending on mouse pointer position, a value can in- and decreased by very fine nuances.

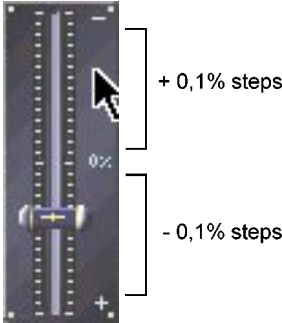

3.02.5. Real Time BPM Counter

Both players automatically calculate the exact BPM value of a title, if no value is indicated in the titles ID3-tag. Via pop up menu, ranges from 50..100, 75..150, 100..200, and 150..300, are available, and can easily be inserted into the titles ID3-tag, so that it is not necessary anymore to determine a title's BPM rate with a separate counter. By clicking [RESET] in the pop up menu, the counter will anew determine the BPM rate, which is useful, for example, to check applied modifications to the ID3-tag.



Player popup menu

BPM Studio	Remove	Remove a title from the player
	Load...	Load a file directly into the player
	Info... Alt+I	Retrieves file information
	Edit... Alt+E	Starts the file editor
	BPM... Alt+B	Starts the BPM counter
	Search... Alt+S	Opens the search dialog box
	Normalize... Alt+N	Applies the normalize function on this title
	Export... ▶	Exports this title as WAVE or MP-3
	Swap Artist-Title	Change title information in the ID3-tag
	Reset ▶	Deletes all defined cue points, fades and playcounter
	Print...	Starts the BPM print designer
	Options... Alt+O	Opens the program options dialog



3.02.6 The Player Window

In general, the player window is divided in two areas. To the upper left hand area, a titles position within a play list is indicated (TRACK) The center area indicates optionally either past play time (ELAPSED), or remaining play time (REMAIN) You can easily switch between these two modes by either clicking in the area, or on the [TIME] button. You can also switch by pressing the according button on the remote control unit.



10 seconds before play time elapses, this display will start to blink in red, thus indicating the upcoming end of this title.

The top right area optionally indicates the BPM of a particular title (this information is retrieved out of he titles ID3-tag), or it's pitch value. As before, here you can also define these settings by simply clicking into the area.

The bottom left area shows a resource meter (audio data buffer size), followed by a spectrum analyzer. In this display the following modes are available, to be switched also by mouse click into the display area:

OFF (very efficient on resources)



Standard balance display



32 Frequencies display with peak levels

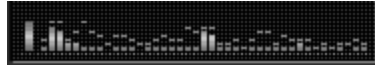

32 Frequencies display without peak levels

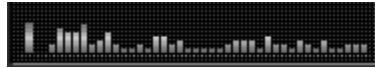

64 Frequencies display with peak levels



64 Frequencies display without peak levels



Amplitude, chronological



Scrolling title and performer information



The pop up menu allows you to switch between spectrum analyzer, and cue point buttons menu







3.03. The Play List

#	Artist	Title	BPM	Time
1.	NO MERCY	WHERE DO YOU GO O	127	7:29
2.	PEARL	THE NEVERENDING S	132	3:38
3.	VANILLA ICE	ICE ICE BABY 2001	137	6:30
4.	VOODOO & SERANO	BLOOD IS PUMPIN	137	4:59
5.	DUSTY SPRINGFIELD	IN PRIVATE	130	4:15
6.	SPARKS	WHEN DO I GET TO SI	123	3:51
7.	GIGI AGOSTINO	PLL FLY WITH YOU	138	7:59
8.	YORK	FAREWELL TO THE M	138	9:09
9.	HIGHLAND	SOLO TU	123	3:42
10.	TRAN-SIZTA	ON THE RADIO	140	3:30

3.03.1. Basic Functions

Every player has an individual play list. Play lists are used to conveniently arrange everything from small title sequences, up to whole event orders. Within the play list, title, performer, BPM, and play length of an audio file are displayed. The blue bar marks a title. All play lists can be stored as play list files. (*.lst)

Generally there are three ways to insert titles into a play list: The pop up menu's [load] function, with drag&drop out of an archive, or with the  button.

The title sequence can also be manipulated, by using drag&drop. A red arrow  assists in this task.

Titles can be sent to the player by either drag&drop functionality, or the pop up menu in the player itself. Depending on program settings, the title will then either automatically start, or be loaded, and pause. The ability to store play lists, allows you to create complete event orders, for events, music genres, show interludes and more. Even importing play lists of other software, like for example WinAMP™ is possible. BPM Studio imports the *.m3u, and *.pls formats.



Titles already in use by the player, (minimum 1 min.) are marked in red.

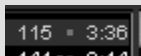

The following functions are also available:



Creates an empty play list



Loads an existing play list



Stores a created list to your hard drive.



Adds a title to a play list



Deletes an title from a list.



Marks all titles in a list



Opens the [File Info Box](#)

The right hand play list areas consists of a status window, and the **monitor player** status window functions can be switched to display with a mouse click.



Displays how many titles are in a particular playlist



Indicates the overall play time of a list



Indicates the remaining play time of a list

Due to the ability to store play lists with their according crossfader effects, you can create complete event orders, for events, music genres, show interludes and more. The actual titles though, are only saved once on your system, even if they appear in different play lists. Read also chapter [Crossfader](#) about how to assign pre defined cross fading effects to titles, or to generate own fades.



3.03.2 Wait List, Single List Mode

Aside from the possibility to have different play lists for every player, there is another display variation, the wait list. In this mode, both play lists are merged to one. With crossfader functions **W** and **P-LIST** you can switch between single list display (play list mode) and dual list display

(wait list mode) When switching from dual to single list display, files will be merged in a comb pattern. When switching back from single to dual mode titles will be arranged in a "even – odd" pattern to the left and right, beginning with title A. Odd numbered titles will be assigned to player A, even numbered titles to player B.



Pop Up menu for play list

BPM Studio	Load in Player	Load title into player
	Play in Monitor	Play Title in Monitor Player
	Remove	Remove title from play list
	Delete	Delete title from hard drive
	Load...	Add title to play list
	Info...	Show File Info Box for marked file
	Edit...	Starts the file editor
	BPM...	Starts the BPM counter for this file
	Search...	Opens the search dialog
	Normalize...	Starts the normalize function
	Export...	Exports a chosen file into WAVE, or MP-3 format
	Swap Artist-Title	Exchange the artist or title in the ID-3 tag
	Reset	deletes cue points, fades, and play counter
Print...	Starts the BPM Print Designer	
Options...	Open program options dialog	



3.03.3. Adjustable Column Width and Content

The columns in the play list can freely be resized, or assigned to fields of the ID-3 tag. For example you can display annotations in place of the version, and reduce the column width for artist. To change a column's width, point the mouse pointer into the head row between to columns. It will change into a bi-directional arrow. Now click, hold, and move to your liking.



The content of a column can be changed as follows:

Right click into the head row of the column you want to change.

Here you can choose what content should be displayed in this column. With the "Align" function, you can set the justification of this column to left or right.



With "Reset", you can restore the default settings. This is especially useful if a column has accidentally been deleted.

Drag&Drop:

Refer to chapter 4.4. (How to work with play lists), for a detailed description of BPM Studios drag&drop functionality.

3.4. Preview Player



Preview players are used to screen titles, marked in the play list.

If the "double click loads

player" is disabled in **program options**, a simple double click on a play list entry will start or stop the preview player. To the right of the player a small peak level indicator is located.

The player's display optionally indicates elapsed time, remaining time, or number of titles in play list.

Preview player controls:

- Jump to previous list title
- Play
- Stop
- Jump to next list title
- Position slider
- Actual play time



The archives preview player can also be controlled with the sample player keys <, 0, and >. Where < serves as BACK, > as FORWARD, and 0 as START, and STOP



3.5. File- and playlist archive



The many available features of the file and playlist archive make it an ideal tool to manage your titles, play lists, and programs, and program archives.

3.05.1 File Archive

By clicking the **ARCHIVE** button in the lower area of mixer, and CD player interface, you can change into the archive mode. The master archive, containing all mp-3 files on your system can be accessed with the **TRACKS** button. Here titles can be categorized by genre, release date, dance style or other criteria. BPM Studio does not limit the number of categories, and sub categories to be created. They will be displayed in the left-hand window of file archives. The right hand window shows the content of these categories, like titles, performers, BPM (if available), and play time.

When creating categories, do not use special characters like / or \. Windows will interpret these as sub-directories, which may cause difficulties.

The buttons **+ FILE** and **+ DIR** allow you to import titles from your hard drives into these categories.

This can also be accomplished by using File Archive's pop up menu. Once available files have been imported, they can conveniently be dragged, and dropped within categories. (Be reminded though that this will only change a files list position, not it's location on your hard drive!) This allows convenient, most simple sorting, and archiving of your titles.

Also by dragging and dropping, audio files are added to, and positioned in **play lists**. More functions are available with following buttons:

- FILE** removes marked files
- SEL ALL** selects all files in a list
- INV SEL** inverts the selection
- SEL ZERO** cancels the selection
- SORT** **automatic sorting**
- FILE INF** opens the **File Info Box**
- FILE SCAN** opens title search dialog

 When creating categories, do not use special characters like / or \. Windows will interpret these as sub-directories, which may cause difficulties.

 Automatic sorting creates a new file archive structure with all artists as categories, and CD names as sub categories. Clicking on this button again will switch back to the previous view.



Pop up menu in category list

BPM Studio	Add Group	Creates a new category
	Add new sub group	Adds a new sub category
	Remove	Removes a category
	Rename	Renames the category
	Clear	Delete a category's content
	Full Expand	Display all categories
	Full Collapse	Closes all categories
	Search... Alt+S	Opens the search dialog
	Add Files...	Adds files to a certain category
	Update ▶	Updates the archive (See additional functions)
	Backup ▶	Back up / restore your files
	Normalize...	Starts the normalize function
	Sorted	Activate/deactivate automatic sort function
	Print ▶	Starts the BPM Print Designer
	Options... Alt+O	Open program options dialog

Pop up menu in both archives title lists

BPM Studio	Play in Monitor	Plays with monitor-player
	Remove	Remove title from list
	Delete	Delete title from hard drive
	Load...	Add titles
	Info... Alt+I	Opens the File Info Box
	Edit... Alt+E	Opens the file editor
	BPM... Alt+B	Starts BPM Counter
	Search... Alt+S	Opens the search dialog
	Normalize... Alt+N	Starts the normalize function
	Export... ▶	Export file as wave or MP3
	Swap Artist-Title	Resets Cue, fades, play counter
	Reset ▶	Starts BPM Print Designer
	Print...	Open program options dialog
	Options... Alt+O	



3.05.2 Play list Archive

The play list archive is used to conveniently manage play lists of, for example, events, programs, or artists. All play lists can be stored in flexible categories. Loading complete play lists into the player is accomplished by using the same drag & drop functionality as with a single title. You can access the play list archive by clicking on

LISTS

(If you want to access play list archive from Mixer or Player, you have to switch to archive mode first by clicking

ARCHIVE

Not like in file archive, the title sequence will not be changed, and titles can be positioned at multiple locations if they are to be played more

than once. With dragging and dropping, parts of play lists can be copied and pasted in another list, or as new selection. Buttons in the lower row of the archive, function the same as buttons described in 3.5.1.

3.05.3. Play List History Function

BPM Studio automatically creates a "PLAYED SONGS" category. In this category play logs will be created containing information about what titles have been played on a particular date. This allows you to analyze successful events, and to reuse parts of them at another occasion – simply by dragging and dropping. Also, printing of lists of played titles for license royalty payments, or event promoter billing, are no problem with **BPM Print Designer**.

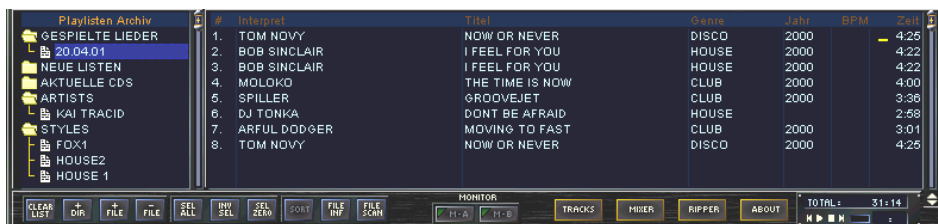

Pop up menu of Category list

BPM Studio	Add Group	Create new category
	Add new playlist	Add new play list
	Remove	Remove category, or play list
	Rename	Rename category, or play list
	Clear	Delete content of category
	Full Expand	Show all sub-categories
	Full Collapse	Close all sub-categories
	Search... Alt+S	Open search dialog
	Add Files...	Add files to list
	Print	Start BPM Print Designer
Options... Alt+O	Open Program Options Dialog	



Monitor switch for player A and B. If the monitor player has its own sound card assigned, and monitor functions are enabled in the systems options (I/O register tab), player A and B output can be configured on monitor out.



In the right lower corner of the file archive a status display, and another preview player, for screening of selected titles, can be found. In the status display the number of titles in the current play list is indicated.

3.05.4. Adjustable column width, and contents

(File Archive and Play List Archive)

The columns in the play list can now be assigned to ID3 tag fields, and resized. For example, assign annotations to the field that displays the version number, or resize the column for the artist's name. This way you can configure File Archive to best suit your needs.

To change a column width, move your mouse pointer over the line between two columns in the head row of a play list. The mouse pointer will change into a bi-directional arrow. Click and hold, and move the line to your liking.



The information a column contains can be changed as follows: Right click the column you wish to modify in the head row, a pop up menu will appear.

In this pop up menu chose what information your column is supposed to display. The "ALIGNMENT" option allows you to choose the column's justification, right or left aligned.



With "RESET", you can restore the default settings. This is particularly useful, if a column has been deleted by accident.

3.05.5. Sorting Order

(Only File Archive)

Titles in File Archive are arranged in alphabetical order. By double clicking into a head row, titles will arranged in order of this columns content. A little arrow in the head row marks this column.

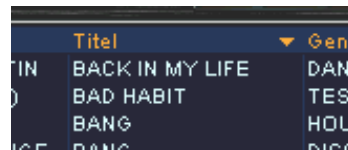







3.06. Loop Sampler



3.06.1. Using the Loop Sampler

-  Sample will be played into its original direction
-  Sample will be played backwards
-  Sample will be played alternating forward and backward
-  Sample will be played to monitor channel, instead of player channel
-  Starts recording
-  Stops both playback and recording
-  Plays the sample
-  Opens a dialog box, to save sample as file

With the loop sampler it is possible to clip sequences from the title playing in the according player, quickly and efficiently; for further processing like editing, playing, or storing for later use. For each player, a loop sampler is available, which can be opened by clicking the [LOOP] button.



Loop samplers are independent modules, which do by no means hinder regular operation of BPM Studio Pro. The operation mode of loop samplers is indicated by a blinking, red





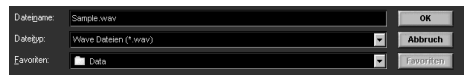

dot in the player's display, located between TIME and PITCH/BPM. It can also be seen in the resource meter of the loop sampler. A red dot stands for recording, while a green dot means playback.

In the **program options**, remote control unit tab, the record, stop, and play functions of the loop sampler can be assigned to the multi purpose buttons **A**, **E** and **C**. Thus it is possible to control loop samplers, without having to display them.

In the "save file" dialog box, either wave or mp-3 file format can be chosen for the sample



-  Moves the start point
-  Moves samples endpoint
-  Adjusts output level from -99.9 dB to 0 dB
-  Adjusts playback speed in a range from -20% to +20%



You can drag and drop samples on a player button.



By utilizing the “+” and “-” buttons, values can be adjusted with millisecond accuracy. Adjustments can also be made by utilizing the keyboard. The tab key switches back and forth between the four controllers. Cursor keys change values in millisecond steps, and page up and /down apply 10-millisecond-steps.

3.06.2. The Loop Sampler Display

This display is divided in three parts. To the lower left a resource meter for the sample buffer can be found. The sample buffer is a reserved RAM area of limited size. When exceeding this limit, which is indicated by the resource meter, reaching 100%, the sample will randomly loop through, and only the last recorded part not exceeding the available, reserved memory will be recorded.

The display to the top right represents the sample graphically. The display right below it shows the following parameters:

- current volume
- current pitch
- Time difference between start of the sample and defined insertion point (P-IN)
- Time difference between start of the sample and defined ending point. (P-OUT)



If you want to use the sample at a later time, you have to save it to disk. When dragging a sample on the player, and dropping it, a merely temporary file will be created.

3.07. Sample Player



The sample player can manage up to 9 samples, which are available for immediate playback by clicking the according button.

A three color LED indicates the player's status. Green stands for READY, the sample player is ready to go, orange stands for ready in scratch mode. A red LED indicates that the sample player is loading data. While loading, playback is not possible.



The sample player consists of nine, numbered buttons. Each one can be assigned to a particular sample. The maximum sample length depends on available RAM. If a button has a sample

assigned, the number on it appears raised. When clicking this button, the assigned sample will be played. When “SINGLE PLAY” in the program's pop up menu is deactivated, simultaneous playback of more than one sample is possible.

Sample player has two different playback modes. In start/stop mode, clicking on the button will start the sample. Clicking on it again will stop it. When in SCRATCH MODE, a button click will start the sample, and every subsequent click will start it anew. You can switch between these two modes either in the pop up menu, or with the keyboards scroll key.

The VOLUME control of the sample player allows adjusting output volume independently from the two player's volume. With the PITCH control, the sample's playback speed can be smoothly adjusted. By right clicking on the control you can reset to the zero position.



With the two  and  buttons, the sample player output can be assigned to either **player A**, or **player B**. This is only necessary though, if the sample player does not have it's own sound card assigned, res., if only two output channels are available. (Depending on hard and software outfit of your system) When both players are used with one sound card, these buttons are of no importance. In the pop up menu a LOOP function can be activated, that will play the sample until the assigned number key is clicked again. The pop up menu is opened by right clicking a number key ().

3.07.1. Editing Samples, and Assigning them to Keys

There are two different ways to assign a sample to a number key. Either in the pop up menu, or by dragging it from a play list or the BPM File Archive, or with the sample editor.

If a sample exceeds the allowable file length of 20 seconds, it will automatically be reduced to the allowable value when loaded.



Please be aware that you need at least 128 MB RAM, if you want to assign full 50 second length samples to all nine channels.

Sample Player Popup Menu

BPM Studio	Play	Play sample (equivalent to clicking the button)
	Loop	Activates / deactivates the loop function for this sample
	Load...	Loads a audio file directly from your hard drive for this key
	Remove	Removes assignment for this key
	Clear	Deletes complete sample block 1 to 9
	Info...	Opens File Info Box
	Edit...	Opens the File Editor
	Sampler...	Opens the Sample Editor
	Single Play	Prevents simultaneous playback of several samples
	Scratch Mode	Switches between scratch mode, and Start/Stop mode
Options...	Opens the Program Options Dialog	



3.08. Sample Editor



The sample editor allows editing of all 9 channels of the **sample player**. It is possible to make adjustments like LOOP, VOLUME, PITCH FADE IN, and FADE OUT.

The nine channels form a sample block, in which any number, or all adjustments can be saved as *.SMP-file by using the **Save** button.

Reset

Deletes all files in the open sample block

OK

Adopts all current settings, and closes the editor window.

Cancel

Closes the sample editor, discarding all current settings

3.08.1 Sample Block Functions

The buttons, located at the window's bottom, refer to the whole sample block.

Load

Opens a dialog box for loading of previously saved sample blocks

Save

Opens save dialog box

3.08.2 Sample Channel Functions

Following settings will be adjusted for each sample individually:



When LOOP function is active, (see also **sample player** pop up menu) the sample will be played in an endless loop.



Volume adjustment for this sample



Plays the sample on the monitor channel



Opens a dialog box for loading samples into the sample channel. Previously loaded file will be replaced.



Pitch value adjustment for this sample in a range from -20% to +20%



Opens the File Editor, for even more ways of manipulating this file. (Refer to Editing MP-3 Files in file editor)



Defining the fade in time for this file between 0 and 5 sec. (Depending on file size)



Defining the fade out time for this file between 0 and 5 sec. (Depending on file size)



Use Sample Editor to save files that have previously been assigned a key in the sample block out of Loop Sampler.

All these functions can be easily reset to 0 by right clicking into the green display, or on the controls. All adjustments can be performed while playing a file.

Popup Menu in Sample Editor

BPM Studio	Play	Plays a sample (same as clicking on PLAY button)
	Loop	Activates / deactivates loop function for this button
	Load...	Load a sample from harddisk
	Clear	Deletes settings for this channel
	Info...	Opens File Info Box for this file
	Edit...	Opens the File Editor for this sample



More information, current sound card test results, program updates, and frequently asked questions can be found on our web site at www.alcotech.de



3.9. Cross Fader



The Cross-Fader is used to fade between player A, and player B. It can be set to either manual, or automatic mode. The automatic mode can be switched on and off, by clicking the **AUTO** button. When automatic mode is active, the fader will by itself fade to the other player, at the end of a title. The fade sequence can be adjusted in the pop up predefined fades, or by

moving the pre set red and blue curve with your mouse pointer. Dragging and dropping assigns a fade to a title. It will always be assigned to the title's end. All subsequent titles in the play list will now have the same fade effect assigned; up the point where another effect is assigned to a title. Titles in the play list with assigned fades are marked with a blue underline. If a already assigned fade is supposed to be modified, the edited fade needs to be reconfirmed by dragging and dropping again. This prevents unwanted overwriting of already assigned fades. All fades will be stored in the play list file.

A red, blinking button, in the upper left-hand corner of the display indicates active auto mode. It will automatically be deactivated as soon as the buttons [CUE], [CUE/PLAY], or [START/STOP] are clicked in either player. With the **FADE** button, the fade can be initiated ahead of time, by using the current titles assigned fade.

When auto mode is not active, fade is initiated by clicking the **FADE** button, it will be executed with the predefined settings shown in the display. This way it will always use the predefined settings, and not the settings assigned to a particular file. **W** switches to single list view.

The fade duration is adjusted with the **FADE TIME** control, where as, it is important to mind that this refers to the whole time frame. Meaning, if the window isn't completely filled, the real fade time shortens accordingly.



Adjusting fade time

A manually controlled fade can be created with the **MANUAL FADE** control



Fader between player A and B

To the top right of the display, the balancing of both channels while fading can be observed. The vertical white line indicates the actual position on the time axis.

In single play list mode, the Cross-Fader appears in a modified layout. Since this mode is normally used during auto fading, six predefined fade settings have been added to choose from. Also the sliders allow for more accurate adjustment. In



the bottom are you can switch back to dual list view by clicking the **P-LIST** button.



When using the MANUAL FADE control, the set fade mode is disregarded

Pop Up menu in Cross-Fader

BPM Studio	X Default	Default fade mode
	T Fade Mode 1	Fade modes 1 to 6
	X Fade Mode 2	
	V Fade Mode 3	
	X Fade Mode 4	
	X Fade Mode 5	
	T Fade Mode 6	
Locked	Arrests the display res. the edit field of Cross-Fader	
Show Clock	Switches between clock, and fader interface	

3.10. BPM Counter



In automatic mode, the base beat of a title is determined by utilizing special filters. The program measures these frequencies, and analyzes them. In manual mode, the value is determined by keystrokes.

3.10.1. Monitor Player of BPM Counter



Beat Counter provides it's own player to play titles to be measured, the Monitor-Player. By utilizing the position slider it is possible to quickly navigate to a given point in a title.

Above the slider, elapsed playtime, and signal level are indicated. The lower three buttons are used to control playback.

This module accurately determines the BPMs (beats-per-minute) of a title and, if desired, saves this value to the ID3-tag and a internal BPM-Database. Two different modes are available.



3.10.2. BPM Determining in Manual Mode



Switch counter to manual. Start the title in Monitor-Player.

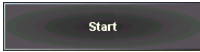

The space key on your keyboard will function as trigger. Press it at every

occurring base beat.

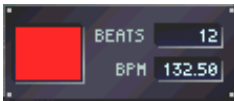

The program now counts every base beat, indicating so by a red, blinking field. If no input is recognized for more than two seconds, the counter will reset to 0.

Watch the displayed BPM value. Once it stops increasing, you can leave the BPM counter by clicking the [OK] button. The determined value will be entered into the BPM database, and displayed in the play list

3.10.3. BPM Determining in Auto Mode



Switch counter to Auto. Confirm by either clicking the [start] button, or

starting a title in Monitor Player. The module will now analyze the title using the same procedure as the automatic beat counters in the players. Independent of these though, the beat of a title will be filtered, and analyzed. Now watch the BPM display, and the red area. When the shown value does not increase anymore, and the blinking is completely synchronized with the title's beat, it can be assumed that the beat value has been accurately determined.

Since it can happen that a title can not be correctly displayed with a standard filter (e.g. red area doesn't blink, but stays red), this filter can be modified. To do so, activate [Filter Correction] in the lower left corner of the filter window.



Upon starting analyzing, you can now adjust the filter frequency range, so that the red area will blink exactly once per beat, and thus will provide clean results.

The horizontal bar can be modified in position, and width, thus changing the filter curve. The vertical slider changes the filter intensity (Amplitude). The so created frequency range will be displayed visually.

After this process is complete the determined values will be entered into the ID3 tag, added to the internal BPM Database, and indicated in the play list.



3.II. File Editor



With the file editor it is possible to cut sequences out of a file, or to set cue points with single beat accuracy. All applied settings like volume, pitch control, cue in, and cue out will be detected by the players and applied, and can also be saved in **Play Lists**.

Once loaded the file will be graphically displayed. The field editor consists of two windows, of which the lower one always displays the file in it's whole length. This way you always have a complete overview of the file, and are able to quickly navigate within it. The top window is used to edit, set cue- start- and endpoints, or to select a certain area for export to a file.

3.11.1. Loading and displaying a Title

When loading an audio file for the first time, initially, peaks will be created, and saved.

3.11.2. Adjusting Display Range



This procedure does not make any changes to the file, it remains in it's original condition. Peaks will be stored on the local hard drive. In **program options**, you can define if these peaks are to be deleted after your done working with the program (more storage efficient), or if they should be saved. (More time efficient)

There are two ways of modifying the top part of the window: Either adjust the width, or move the area bar back and forth between the

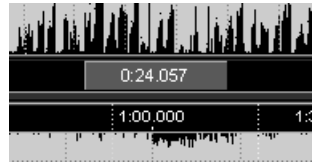



bottom, and upper window. The upper window always shows the area, marked in the lower window.

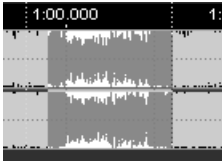

When marking areas with the magnifying function by right clicking and moving the mouse pointer, the inverted area will be magnified, and displayed in both windows. The area selection can be made on both windows.

By double clicking into the inverted area you can switch between zoomed and overall view.

3.11.3. Marking ranges, and exporting into files

Deactivate the magnifier function , and mark an area in the upper or lower window by holding right mouse button and moving. The marked area will appear red. To modify keep right mouse button pressed, to open pop up menu, with options like zoom, play, and save as *.wav or *.mp3 single right click. Save as file, if you wish to work with selection at a later point.

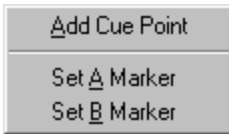

3.11.4. Adjusting volume and pitch



The volume control allows to set output volume between -20 to 0 dB



The pitch range can be modified by +/- 20%

The + and - keys allow fine adjusting these values. They will be saved, and applied when loading file into player. The set pitch value will be added on top of the value the player is set for.

The Toolbar



Stops playback in file editor



Starts playback in file editor



Jumps to beginning of selected area. If no area selected, jumps to title start, if playback is stopped, sets locator back to title start



Plays marked area in a endless loop



Assigns magnifier function to right mouse button



Displays the audio file in wave format



Displays audio file as dots

3.11.5. Functions of different markers

The file editor recognizes four different markers, which can be used to mark different positions or areas within an audio file. All markers can be edited via pop up menu in the in the marker row, or moved with the mouse pointer.



The red locator – indicates the current play and pause positions, and can equals the position sliders in players, and Monitor Players. This marker can be positioned by left click.



The blue entrance and end markers – mark the beginning and end of a title. They, also, can be moved either with the mouse pointer, or via pop up menu. Once placed, the position slider in the **players** will use these markers as new start and endpoint of a title.

The yellow cue point markers – indicate cue points. They also can be moved with the mouse pointer. Via the pop up menu in the marker row, additional cue points can be inserted

The blue cue point marker – indicates the active cue point. The active point is defined by either in the cue point list to the top right, the pop up menu, or the CUP button in the player.

Since players have only one CUE and CUP button, one of these points will be defined as standard cue point. This point will be used as default whenever CUE or CUP is clicked. To manage cue points, the file editors cue point list, in the upper right corner is used. Here the cue points are listed with their exact location (1/1000sec. Accuracy) The current cue point is marked with a blue bar. When playing the title in the field editor, this bar travels, and always indicates the last passed cue point.

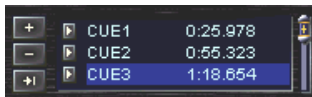

Adds a cue point

Deletes selected cue point

Defines selected cue point as standard

Plays title from selected cue point on, places locator to selected cue point

3.11.7. Working with cue points

A cue point is a position within a title recognized by players as start point. The CUE button in players navigates to these points, and the CUP button starts playback from this point on. (Equal to CUE and PLAY) The file editor can assign up to nine cue points within each title.



Ex version 4.2 of BPM Studio the cue points defined within the File Editor are also wrapped as DirectCue points when loading the title.

Marker Row Popup Menu

	Defines current cuepoint as standard
	Deletes current cuepoint
	Places start marker at this position
	Places endmarker at this position.



3.12. File Info Box



The File Info Box allows editing the entire ID3 tag. In the **program options** you can choose to save this information in the new ID3v3 format, or to keep the old ID3 format. If the File Info Box is opened from multiple selections, an additional drop down menu appears, allowing you to select, and edit particular titles.

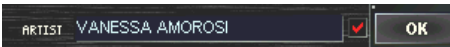

If you want to change an entry for all selected titles mark the related checkbox for this entry and confirm with OK.

The “GENRE” field generates a drop down menu, allowing you to assign titles to different styles. This way you can categorize titles, which allows for convenient searching later on.



- OK** Confirms changes
- Cancel** Cancels without saving changes
- More...** Retrieves additional information if the file has been ripped from CD by using CD-at-once. This button only appears if the whole CD has been ripped as one title
- BPM...** Starts the BPM Counter for that title
- Edit...** Opens this title in file editor.



3.13. Mixer



The Mixer contains of four components, which are displayed as pairs. In standard view, to the left the **audio channels** are located, and the equalizer to the right. In the master channel (sum of all audio signal sources) a **Compressor /**

limiter module (AGC – Automatic-Gain-Control) can be switched into the channel, by clicking the **AGC** button, below the master volume control. Optionally the equalizer display can be replaced with the **recorder** by clicking the **RECORD** button.



The mixer merges all internal, and external audio sources. For players A and B, and the CD-ROM drive frequency ranges can be adjusted and corrected. The AGC is responsible for a steady, constant output level, and prevents through a limiter overload of the connected PA system. With the **Recorder** it is possible to record the audio signal from an external audio source (MIC or LINE IN). Recordings can also be done from the currently loaded program of both players. Recordings can be saved as either *.mp3 or *.wav files, or they can also be sent to a streaming server.

3.13.1. Audio Channels

The audio mixer has four internal stereo inputs (Players A and B, CD-ROM drive, and Sampler), and two stereo outputs (Master, Monitor). The recorder supports two sound card inputs (MIC and LINE IN). The level control allows adjusting the volume for every single stereo channel separately. A level indicator to the right of the control indicates the volume. The dB values of the individual channels are indicated to the top right. Using the panning field to the top right, the channel balance can be shifted. A right click resets to zero. Channels can be muted by clicking the [MUTE] button.



Level indicators can be turned off in the program options. This saves system resources.

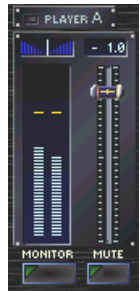



Each input channel's monitor button (Players A and B, CD-ROM, and Sampler), allows to route the audio signal through the MONITOR output channel, where it can be played independently from titles currently played by the players. This requires of course that the monitor options are enabled in the program options, and that the monitor has disposition over it's own sound card.

To the left of the channel designation beat displays for every input channel can be found. The MASTER-Output controls the overall volume of all four input channels. Located close by, is the AGC Module button, indicating by a little LED in it's center if it is active or not.

All control can be reset to a value of -1.0dB by simply right clicking on them.

permanently, the overall amplification of the equalizer is set to high, which can cause distortions. In this case it is recommended activate the PREAMP (Limiter) function, or to make according adjustments to the equalizer settings.

The to start the recorder click on the **RECORD** button

3.13.3. Loading and Storing Equalizer Settings

BPM Studio supports loading and saving of as many different equalizer settings as you like. Also, predefined templates are available. To manage your settings use the "Presets" function in the equalizer's pop up menu.

3.13.2. The Equalizer

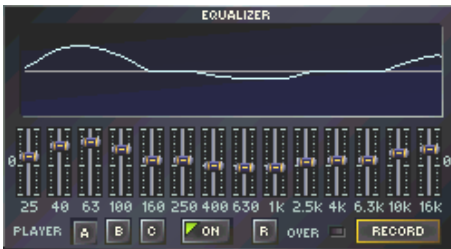

The equalizer is used to adjust and correct frequency ranges of Players A, B, and the CD player. Individual player settings can be opened by clicking buttons **PLAYER A**, **B**, **C**, and be activated and deactivated by clicking **ON**. The controls allow to adjust every single one of all 14 frequency ranges individually. These settings are graphically displayed in a curve, located in the display above the controls. By right clicking into the display, or a click on the **R** button, this curve will be reset to linear frequency ranges. If the red OVERFLOW LED comes one

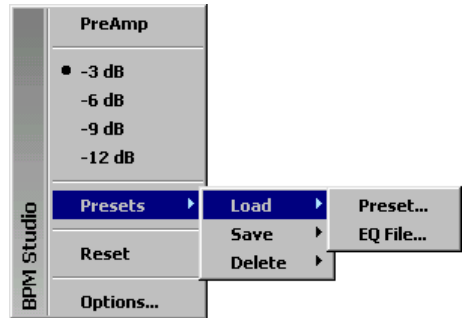



The Equalizer Popup Menu

BPM Studio	PreAmp	<u>Limiter function</u>
	<ul style="list-style-type: none"> ● -3 dB -6 dB -9 dB -12 dB 	Signal Subsidinging
	Presets ▶	Opens the equalizer settings menu
	Reset	Resets settings back to zero
	Options...	Displays the Program Options

3.13.4. Recorder



The **RECORD** button in the equalizer opens the recorder. The MIC and LINE IN controls are used to manipulate two input signals of any sound card. To choose a sound card use the controls pop up menu. Also, the **MP3-Stream-Module** can be chosen there. The RECORD IN control is used to manipulate the overall recording, and transmitting level.

The **RECORD** button starts recording, res. transmitting. The **MONITOR** button allows to adjust recording levels before doing so. The current recording is marked by a red dot, and a counting elapsed time counter (**0:00:33.7**).

STOP Ends recording. If you have recorded

in WAVE or MP3 format, a dialog box will appear asking you to define name, and in what directory this file should be saved. **AUTO** automatically starts recording, if a predefined input starts to receive audio data.

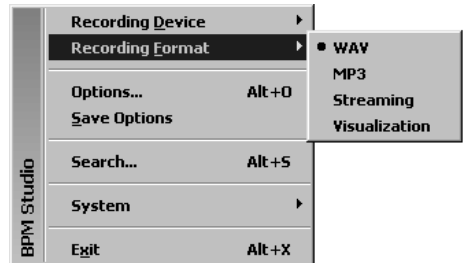

In the menu point "RECORDING FORMAT" you can determine to what file type your audio data is to be converted. Available are **WAVE format** (resource efficient), **MP3 file** (storage capacity efficient), **MP3 Stream** to a streaming server, or output to a **Visualizations Plugins** interface. Streaming module and visualization interface are subject another point in this manual. The **EQ** button leads back to equalizer.



Recorder Popup menu

BPM Studio	Recording Device ▶	Select sound card for recording
	Recording Format ▶	Select file format fore recording
	Options... Alt+O	Dialog for program options
	Save Options	Save settings
	Search... Alt+S	Opens search dialog
	System ▶	System functions
	Exit Alt+X	Exit BPM Studio



To record a current program, all virtual devices need to be assigned to the same, duplex capable, sound card. The windows mixer settings for this card need to be set on enable WAVE recording and LOOP functions. And this card needs to be chosen as recording device in the RECORDER field.

3.13.5. Compressor/Limiter (AGC)

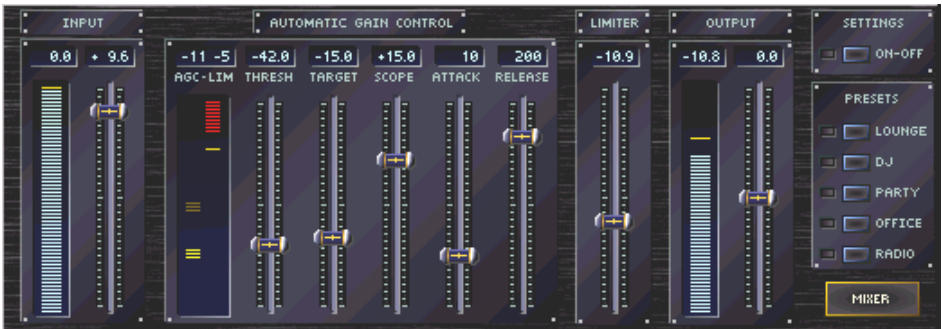

Especially when recording MP3 files serious differences in volume level may occur. Reason for this are usually differently mastered CDs, or deferring encoding parameters, when different

encoding software is used. The AGC module compensates these differences in real time, and provides a stable audio output signal. The module can be adjusted in three level-, and two time parameters.



The AGC-Modul is developed primary for using with background music or pre-defined playlists. So this module will be work only in Autofade Mode in the current program version.

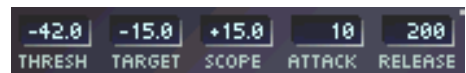



Threshold

(Adjustment level -60 to 0 dB)

This parameter defines the trigger level of the control. Soft passages or silence at the beginning and end of a title will not be changed to avoid negative impact on a titles total dynamic. This also prevents unwanted increasing and amplifying of unwanted background noise.

Target

(Adjustment level -21 to -3 dB)

This is the predefined target output level. AGC will try to raise or lower every level that is louder or quieter than the threshold level.

Scope

(Adjustment level 0 to 21 dB)

This value defines the max. amplification or diminution, thus defining the intensity of the control. If, for example, a peak level exceeds more than the scope value over the target, it will only be decreased by the max. Scope value.

Attack

(Adjustment level from 1 to 500ms)

With this parameter the latency of this control can be adjusted. Peak levels lasting shorter than this value, will not be recognized by the AGC.

Release

(Adjustment level 1 to 500ms)

This parameter defines how long it takes for the intervention to abate res. how long it takes to go back to regular output level.

Limiter

(Adjustment level -18 to 0 dB)

The limiter restricts levels at very short reaction time. It's purpose is to restrict the signal level, to protect devices in the following signal course like external mixers, cross overs, output stages, and speakers from over modulation and overloading. Below it's predefined trigger level it stays inactive.

Input / Output

(Adjustment level -12 to 12 dB)

These two controls allow a linear adjustment of input and output signal. The displayed bars represent signal level before and after the change.

Displays within the AGC Module

The display within the AGC modules consists of the compressor display (left), and the limiter display (right). If the amplification indicator is positioned in the center, the signal loops through the AGC module without modification. If the indicator travels below the zero level, the input signal is too strong, and is weakened by the module in accordance with predefined parameters. Vice Versa, the signal will be amplified, if the indicator travels above the zero level.



The red bar in the top right hand corner indicates the trigger level of the limiter. The peak level at the AGC's signal output is marked in yellow. As long as this marker moves below the red area, no modifications will be applied. Should this marker touch the red area, the signal will rapidly be lowered to the defined maximum peak level.



The Limiter also allows to restrict very short peak levels, which the AGC would not address, since the AGC response time is way shorter than the duration of exposure it would take to overmodulate, or even damage equipment.



The AGC only works in the auto fade mode. Even if the AGC is active, it will not be of any effect if auto fade is not active.



AGC Presets

For quick deployment of AGC, five pre defined parameter sets are available. These are adjusted situation specific. Select a preset most suitable for your need, and fine adjust it for your purpose.



starts and stops the AGC module



Mixer switches back to the mixer audio channels.

Work method of the AGC

Following is a quick description of the work method of AGC at different input levels. (See also diagram on next page)

All shown values are standard values and can be, depending on application, changed.

Up to point A the AGC does not take effect, since the input level does not reach the threshold level of -42dB.

From point A on, the AGC gets active, trying to raise the output level to the target of -15dB since scope is set to a value of 15dB, the signal can only be amplified by 15dB.

From point B on, the input signal is less than 15dB (Scope) smaller than the target, and the AGC is now able to define the output level to accurately -15dB. The volume difference between point B, and point C will be balanced out, since in any case the deviation is less than the 15dB scope.

From point C on the input signal is more than 15dB stronger. The AGC lowers the signal by 15dB.

Meanwhile the output signal exceeds the 10dB limit set by the limiter, and will immediately cut off. At point D then, the volume difference of input signal to target is lower than the scope value, and the AGC can level to the -15dB target again. Between E and F, the amplification reaches it's limit of 15dB again.

From point F on, the input level will again fall short of the action range of the AGC, and the input signal will again be routed to the output unchanged.

In this diagram it is assumed that changes are made without delay. If according values are defined for attack and release, the controls trigger- and fade behavior is delayed accordingly.

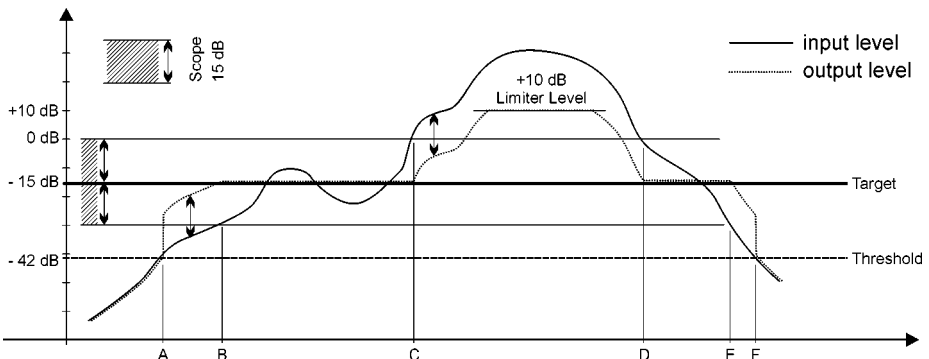



3.14. MP3 Streaming Modul

This module allows you to directly send an MP3 stream in an internal network, or to a streaming server in the Internet. The

streaming module appears automatically, if you select "Streaming" in the recorders pop up menu. You can hide the module by clicking in its top right corner, and reopen it by clicking the according icon in the task bar. Anyway, it stays active as long "Streaming" is selected as recording format in the recorders pop up menu.

Format: MP3 @ 24kbps 22 set

In this field the file format for the stream can be defined. Please select these settings in consideration of your available bandwidth.

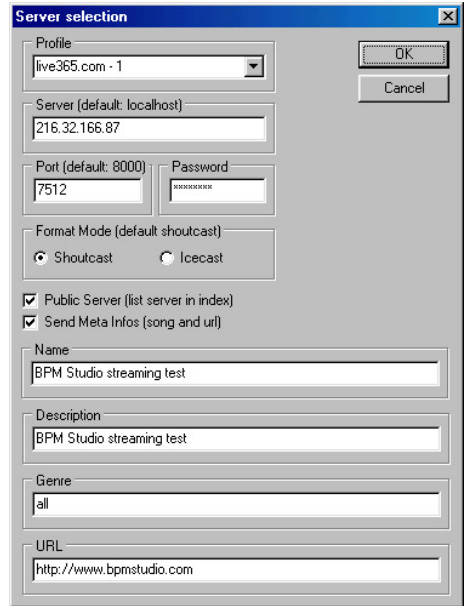
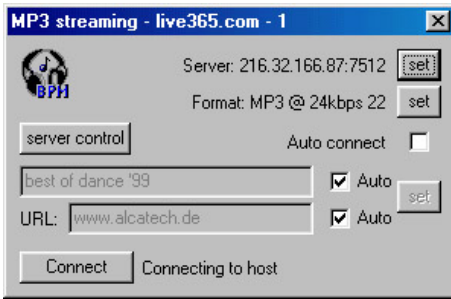

With the two SET buttons settings for server and file format can be defined. These settings have to match the settings of the stream-server. Currently supported protocols are Shoutcast and Icecast.

Server: 216.32.166.87:7512 set

This field indicates the current server. The set button opens the server settings dialog, where various configurations can be created and stored.

PROFILES:

Allows naming and saving of different configurations

SERVER:

Define URL: or IP Address of the selected stream server

PORT, PASSWORD:

Are also to be defined in accordance with the stream server's settings.



Shoutcast Icecast

Use the check marks to select the desired transfer protocol. Shoutcast and Icecast are currently used by the stream server providers shoutcast.com and icecast.com. These are free for noncommercial use. More information can be obtained on the according web sites. The following informations are used to publish your "radio station" in server directories.

Public Server (list server in index)

if you have checked the "Public Server" check box.

Send Meta Infos (song and url)

Send Meta info causes title- and artist name to be sent along

Auto
 URL: Auto

This information is sent parallel to your MP-3 stream. You can enter e.g. the title of your show, and your web URL:

If the two [AUTO]-checkboxes are marked, the actual title and URL will be adopted from BPM Studio (provided auto fade is active) and the server settings dialog, and entered into the directory.

server control

Opens the web browser and navigates to the servers status page

Connect

Establishes connection to the server

Disconnect

Terminates the connection to the stream server. (This should always be done before exiting

BPM Studio)



Even with marked AUTO checkbox, title information will only be sent properly, if auto fade mode is active.



3.15. CD Player / CD Writer



The CD player / CD-writer provides all functions necessary to work with CDs. Here, reading in CDs, and compressing to MP3 format is accomplished. You can also burn titles on CD-Rs as audio CD to be played with conventional CD players, or as data CD for back up purposes.

The Play List and the player module are similar in structure and handling to the two main players and the Play Lists.

The CD-Reader also functions as device for reading in audio CDs, and copying them to hard drive. Read also in chapter 4 step-by step instructions for copying, and compressing audio CDs.

To do so, three different modules are available:



3.15.1. CD-Reader (CD READER):

With this module, also called CD Player, you can use your CD-ROM drive as fully functional audio CD player. All functions like Pitch, Master-Speed, Pitch Bend, Cue-Points, etc. are available without restrictions. The playback can be routed through a separate sound card channel, and will be treated as separate audio channel in the mixer. Also, MP3 files can be played with this player. Simply drag a title out of a Play List or archive, and drop it on the CD player; and use it this way conveniently as Monitor Player!

3.15.2. Encoding audio CDs

Generally encoding (compressing into MP3 format) can be done in two different ways. Either by saving an audio file in WAVE format and later on conversion or by immediate compression to MP3 while reading in. This choice is made in the Program Options, on the register tab CDDA-Copy / Configuration / Encode during copy. If this checkbox is marked, copying and encoding will be done in a one step process. When compressing large numbers of audio CDs it is recommended to read all of these in, in high-speed mode as wave format, and then batch compress them in Encoder Mode over night, for example.



Whenever an audio track is loaded in one of the players the CD ROM drive will be locked. It can be unlocked by either choosing "Remove" in the players pop up menu, or by pressing the eject button.



The CD Player also supports MP3, and WAVE formats, thus, it can be used as third MP3 player, or as convenient preview player.

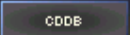

3.15.3. CDDB-Query

Upon inserting an audio CD in the CD-ROM drive, the titles in the Play List will appear as numbered tracks. Now click the  button.

Provided so configured in windows, the PC will connect to the Internet, logs on to the CDDB (database for administration of title information of audio CDs) and attempts to find information about the inserted CD.



If successful the information will be transmitted, and displayed in the Play List. These informations will also be saved on your PC, so that they'll be available when this CD is inserted again.

Query for several CDs (Batch-Function):

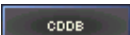
As soon as an audio CD is inserted, BPM Studio will store the CD code. With the next CDDB query, it will be attempted to retrieve all information, for CDs not yet identified. You can save time, by inserting audio CDs, wait till their track numbers are displayed, and then click on the CDDB query button .

Now all title lists of these CDs (if available) will be retrieved, and be available when the CD is inserted again. After completion the Internet connection will be terminated. You can also establish the connection manually via the pop up menu of the CDDB – button. On the CDDA-Copy register tab in Program Options different CDDB servers can be selected.



Information downloaded from the CDDB server will be stored by BPM Studio, and will be available without being online.

3.15.4. Copying Audio CDs (Ripping):

After successful CDDB query all CD titles will be displayed in the Play List.

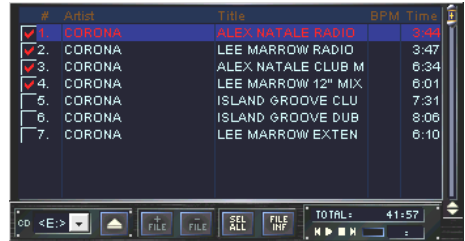

If no information has been available for this CD in the CDDB database, you can now enter it manually in the **File Info Box**.

Now mark the titles to be read in with the left-hand check box, and click on .

All marked titles will now be read in. Progress is displayed in a status window.



It is mandatory to enter title information manually, or to download it from CDDB, BEFORE titles are being ripped. Otherwise BPM Studio can only use CD-Code, and track numbers as file name.



#	Artist	Title	Type	Year	BPM	Time
1.	AQUA	BARBIE GIRL	MP3		130 BPM	3:17
2.	AQUA	GOOD MORNING SUNSHINE	MP3			4:04
3.	AQUA	HAPPY BOYS & GIRLS	MP3			3:37

If the “encode during copy” function, on the CDDA register tab of **Program Options** is active, read in titles will immediately compressed into the MP3 format, and stored in the according folder. This folder can be defined in the “storing” register tab in **Program Options**.

After successful encoding all titles will automatically be listed in the “NEW FILES” or “NEUE DATEIEN” category of file archive. For more clearness a subfolder for the current date will be created. (See picture on top of page)



3.15.5. “CD at once” Mode of CD player

The “CD at once” mode allows to rip and archive a whole CD as one single title. This is useful if you, for example, want to read in a mixed CD seamlessly, to replay it as a single title later on. Also when reading in particular albums, of which the title order needs to stay unchanged, it makes sense to read in the CD in one piece. To do so start the copying process with the pop up menu (right mouse button) of the **COPY** button.

whole title list of the original CD can be displayed, provided it has been ripped with the “CD-at-once” mode.

It is also possible to select single titles with the **Player** or the remote control unit (only RCP-1001 and 2001) directly.

If you click the track buttons of **Player** with the right mouse button, the next title (or previous) within one of these “CD-at-once” titles will be started.

Equally you can use the track selector buttons [12] of the remote control units RCP-1001, and RCP-2001 to navigate within one of these CD-at-once tracks by pushing, and turning it at the same time. The subtitles will then shown in the VFD display



All titles will be ripped as single track, and also added to the file archive as single title.

But information about single titles won't be lost! The button “MORE”, in the **File Info Box**, the

3.15.6. Encoder :

The encoder converts WAVE files into the MP3 format. Here you will find all previously read in audio-CDs, if you do not have activated the “COPY/ENCODE” option in the Program Options, before ripping. Also, the encoder can convert other, already present WAVE files, that have been ripped with other programs. Simply drag them out of the Windows Explorer, and drop them on the

encoder Play List, or, add with the  button.

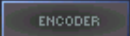

For screening, and controlling also the CD Player can be used. The files can be played, controlled, and edited with the File-Editor. Following, the marked part will be transferred to the MP3 format by clicking the  button.

After compression is completed, you'll find a new entry in the BPM file archive under NEW FILES with the actual date, in which the compressed files are being stored. This folder can be renamed with the RENAME button, or you can assign those titles to other present categories.



Eject button opens and closes the selected CD-ROM drive.

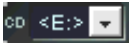

CD-ROM Selection field. Here you can select the CD-ROM drive to be displayed.



Starts copying selected titles. By right clicking you can open a pop up menu, allowing you to copy a whole CD as CD-at-once track

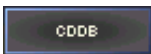

Starts the CDDDB-Inquiry. The right click pop up menu allows you to manually establish a connection to the Internet, if a connection is available in the Windows system settings.

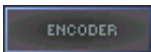

(Only active in the Encoder) Starts the encoding procedure for selected titles.

3.15.7. CD-Writer

Produce your own audio CDs with your own mix or compilation - all with only one program: BPM Studio.

The integrated burner supports all common CD writers and media. Even burning MP3 files is no problem. Thus you can conveniently create backup copies, and quickly transfer play lists with the according tracks to another system.

Before you start to create CDs, we recommend that you make yourself familiar with the handling of CD-R's, and CD-RW's. Also check the CD Writer settings on the according register tab in the Program Options. In this manual, chapter Program Options, you'll find all important instructions and explanations to optimally configure your CD Recorder. Once set up, the BPM Studio CD writer allows you to very simply and quickly create Audio- and Data-CDs.

Generally start a new CD project with the  button. In the following dialog you can decide whether to create a Data- or a Audio-CD:

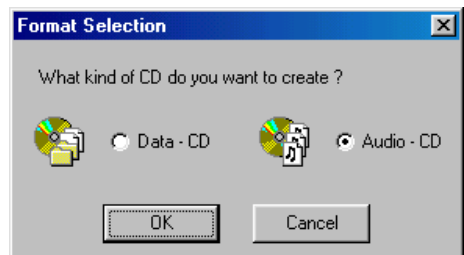

The screenshot shows the BPM Studio interface. On the left, a track list is displayed with columns for #, Interpret, Titel, Jahr, and Zeit. The track list includes:

#	Interpret	Titel	Jahr	Zeit
1.	FRAGMA	YOU ARE ALIVE	2001	4:46
2.	BARTHEZZ	ON THE MOVE	2001	8:04
3.	BLANK & JONES	DEEJAYS FANS & FR	2001	0:38
4.	COSMIC GATE	EXPLORATION OF SP	2000	8:02
5.	FRAGMA *BOW TO IDC	EVERYTIME YOU NE	2000	5:17
6.	AIRHEADZ	STANLEY	2001	6:30
7.	MARIO LOPEZ	ONCE IN YOUR LIFET	2000	6:20
8.	MAURO PICOTTO	LIKE THIS LIKE THAT	2000	5:25
9.	PULSEDRIVER	CAMBODIA	2001	7:34
10.	RUI DA SILVA	TOUCH ME	2001	5:29

Below the track list are buttons for CD operations: WRITE, TEST, ERASE, CD READER, CD WRITER, and ENCODER. The right side of the interface shows playback controls for the CD player, including TRACK (04), ELAPSED (02:34.80), PITCH (0.0), and buttons for CUE-PLAY, CUE, and PLAY-PAUSE. There are also buttons for MIXER, ARCHIVE, SHUFFLE, and TEMPO.



3.15.8. Creating Audio CDs

Select this mode if you want to create a CD that can be played with any common CD player or changer. The maximum play length depends on the type of media you use, and vary between 74 and 80 minutes.

(Pay attention not to exceeding the media's maximum play length when assembling the title list. If you do, an according message will warn you before the write process.)

The title order can be modified by Drag&Drop. Start writing with the **WRITE** button. In the following dialog fields, progress can be monitored, and modified.

After confirming the dialog box by clicking [OK] the selected CD format will be displayed in the track list status bar.



Place the media to be recorded into the Recorder. The CD status indicator below the track list gives you information about this media, and the Recorder itself.



Now you can load any title or whole Play Lists in the writers track list. This can be done in different ways

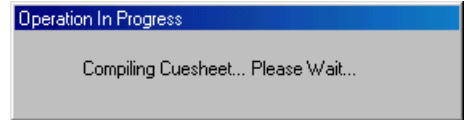

At first, the Cue-Sheet will be created. It contains information that will be written onto the media parallel to the audio data, such as starting points, title length and (if the Recorder supports this function) CD text information. Upon completion, a dialog with the calculated data will appear.

- 1.) Drag & Drop from the from Play Lists, file archive, or Play List archive.
- 2.) Via the clipboard, with "copy" and "paste" (Ctrl - C / Ctrl - V)
- 3.) With the **LOAD LIST** button you can load any Play List present on the hard drive.
- 4.) With the **+ FILE** button you can selected tracks directly from your hard drive.

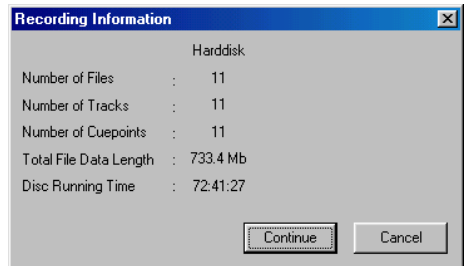

The status bar to the left indicates overall length of the CD. Additionally a status bar below the track list displays the remaining capacity of the media.

Here you can check if all the data is correct, if so confirm with [next] and start the writing process. Of course you can still abort with [cancel]



It is not necessary to convert MP3 files into the WAVE format. All tracks can be loaded into the writer as MP3s. Decompression is done in real time during the burn process.



Please avoid writing CDs over a network. If you use BPM Studio in a network, the CD Writer should be local, with the MP3 or WAVE files to be burned.



The following status windows keeps you informed about the whole writing process

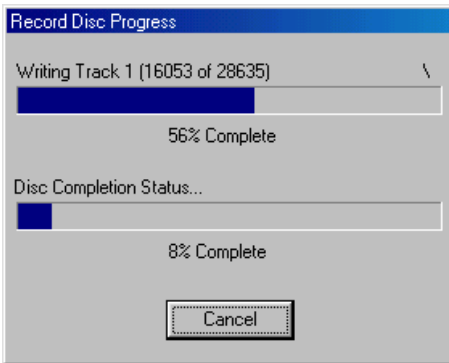

After successfully writing the CD, the drives slide will open, and you can take out the CD

3.15.9. Creating data CDs

Select this mode if you would like to copy MP3 files already present on your system to a CD, that can later on be played on a PC with a standard CD ROM drive installed. Thus, you can back up files easily, or transfer them to another computer. The maximum available drive capacity depends on the used media, and usually varies between 650 to 700 MB.

Start a new CD project by clicking the  button. In the following dialog box select 'Data-CD'

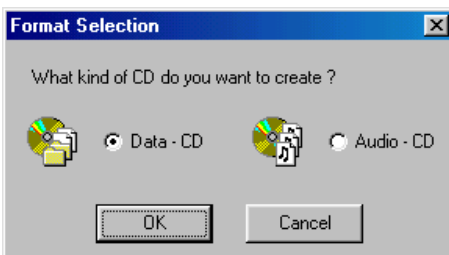



The selected mode will be indicated in the status bar to the left.

Now insert the media into the Recorder. The CD status window to the right below the status bar indicates, as when creating audio CDs, the contents of the CD, and the Recorder.



Now you can load selected titles, complete Play Lists into the Recorder.

This can be done in various ways:

- 1.) Drag & Drop from the from Play Lists, file archive, or Play List archive.
- 2.) Via the clipboard, with "copy" and "paste" (Ctrl – C / Ctrl – V)
- 3.) With the  button you can load any Play List present on the hard drive.
- 4.) With the  button you can selected tracks directly from your hard drive.

The status bar to the left shows how much storage space on the media is already in use. Additionally a status bar to the right below the track list indicates the required disk space. (Pay attention not to exceed the media's maximum play length when assembling the title list. If you do, an according message will warn you before the write process.)



Please make sure that with BPM Studio only work you authored, or work of which you are explicitly allowed by author or someone in lieu, will be copied. Otherwise you might commit the offense of copyright fraud, which is a federal felony, or be held liable by the author, or designated people in lieu of.



Start the writing process by clicking the  button. In the following dialog field you can control the progress and manipulate the writing process. Explanations of the according dialog boxes can be found in the previous chapter "Audio-CD"

3.15.10. Systemtest in test mode

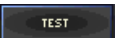
If you start the writing process with the  button, it will only be simulated. Your computer will perform all actions that it would perform in a real write, with the exception that the laser will be disabled. This is very useful to test the system performance. The media will not be changed in this mode.

3.15.11. Deleting CD-RW's

(If supported by the Recorder)

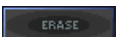
If a CD-RW (CD rewriteable) already containing data is inserted into the drive, you can delete this data by clicking the  button.

Adding another Session:

(Data CD only)

You can add data to an unfinished media that contains data already, in a new session. To do so, the "import session" function on the CD-Writer register tab in Program Options must be enabled. When inserting such a media, the used storage capacity will be indicated in the status bar.



Eject button opens the tray of the selected Recorder.

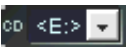

Select Recorder field. Select here which Recorder is to be used.

Important Note

A list of all supported CD Recorders can be found in the version history, which is delivered with every version of BPM Studio.

Please have understanding for the fact that we can not support every CD Recorder on the market. This is not the objective of BPM Studio, and it does not claim to be a full-featured CD recording program. Much more BPM Studio is primarily a DJ system for live performing.

Please make sure that in case of problems with burning CDs the first step should be to reduce the speed. Not every media can record at any speed. Anyway you should disable auto load for every available CD player; otherwise problems may arise, especially when burning CDs.

Should there be any further problems consult the following website:

<http://www.disc4you.de/kompendien/cd/>
(German)

<http://www.brennmeister.com/articles/aspi/>
(German)

<http://www.ncf.carleton.ca/~aa571/aspi.htm>
(English)

http://www.goldenhawk.com/firmware_body.html
(English)

We recommend paying especial attention to sites concerning firmware upgrades, and ASPI drivers.



3.16. BPM Print Designer

Print & Export								
	Artist	Title	Album	Version	Year	Genre	Type	Time
1	WOODOO & SERANO	BLOOD IS PUMPIN			2000	TRANCE	MP3	4:59
2	SANTOS	CAMELS	MOS THE ANNUAL 2000 CD01 - M...		2000	DISCO HOUSE	MP3	3:32
3	YORK	FAREWELL TO THE MOON			2000	TRANCE	MP3	9:09
4	VANILLA ICE	ICE ICE BABY 2001			2000	TECHNO	MP3	6:30
5	GIGI AGOSTINO	I'LL FLY WITH YOU	VICIOUS VOCAL		2000	DANCE	MP3	10:...
6	GEORGIE PORGIE	LIFE GOE'S ON	CREAMFIELDS 2000 (CD 1)	RICHARD F'S...	2000	DISCO HOUSE	MP3	4:35
7	MIRWAIS	NAIVE SONG	PRODUCTION		2000	TECHNO	MP3	4:23
8	HIGHLAND	SOLO TU	SOLO TU (MAXI)		2000	DANCE	MP3	6:23
9	DELERIUM	SILENCE	MISC DANCE	DJ TIESTO MIX	2000	TEST	MP3	11:...
10	AVENIDA	CHANGE	DISCO HOUSE 1 CD 1		2000	DISCO HOUSE	MP3	3:45
11	ATB & YORK	FIELDS OF LOVE				TEST	MP3	3:09
12	FLOORFILLA	ANTHEM #4	DJ CERLA FLOORFILLER MIX	DJ CERLA MIX	2000	DANCE	MP3	6:14
13	MAGIC VOICES	AUSTRALIA				TEST	MP3	3:25
14	(BEAM VS CYRUS)	THUNDER IN PARADISE		CLUBMIX	2000	TEST	MP3	6:31

Sort by: Columns: Autosize Multisort

Need to print a Play List? Need a printed summary of a particular category, or complete archive? A list of titles played last Saturday to report to the promoter, or the GEMA? A taker asks for your repertoire?

All this is no problem with the BPM Print Designer! Printouts can be fitted to any need with extensive selections of sorting orders, and a variety of possible adjustments. Of course print previews are also possible. To use lists in other programs, they can be saved as text files, as well as in other formats.

3.16.1. Starting BPM Print Designer

The BPM Print Designer can be started from within **File Archive**, **Play List Archive**, or the different **Play Lists** via the according pop up menu entries.

Depending on selected category or Play List, up to three selections can be made:

Print Group:

Titles of selected category will be adopted into Print Designer for printout,

Print Group with Subgroups:

All titles in a selected category, including all subcategories will be adopted into Print Designer for printout.

Print Archive:

All titles of all categories, and subcategories will be adopted into Print Designer

Now the main screen of Print Designer will be displayed, with all selected titles. Here you have the opportunity to make various adjustments, and to choose which title information is to be printed.

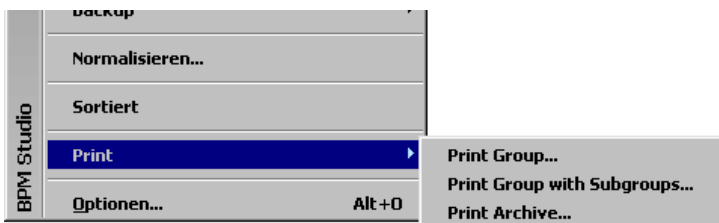



3.16.2. Export List Window

Selecting Fields to be Printed:

First select all fields that are to appear on the printout. To do so, open the pull down menu



And select the desired fields of the ID3 tag.

Change order of columns:

The head row of the title column can be dragged, and inserted at a selected position:

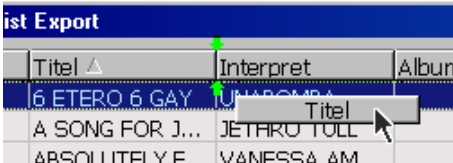

Thus you can adjust the order of columns to your liking.



By clicking into the bottom right corner of BPM Print Designer, and holding the mouse button, you can adjust the window size of the main screen.

Adjusting column width:

In the head row, click on the marker between two columns:

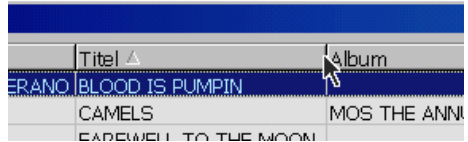

Keep the mouse button pressed, and move the pointer sideways.

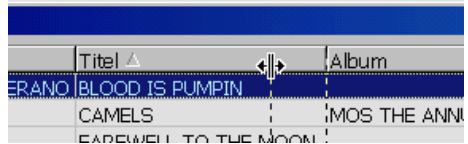

Thus the separator between two columns can be moved, and the column width is adjusted.

Automatically adjust column width:

If you check the **Autosize** checkbox, all columns will be adjusted to the longest entry in this column.

Selection of sorting order:

The titles to be printed can be sorted by any or several columns. For a simple sort, by only one column, just click on the head row of the column. This row will be marked with a little arrow. With another click in this column you can switch between ascending, and descending order. The arrow will indicate the selected order. Another way to select the column by which to sort is the pull down menu.





Multiple sorting:

Use this feature to define your sorting order by more than one column. When check box **MultiSort** is selected, the arrow to indicate sorting order changes to yellow, and will be marked with a 1. Now you can select more columns by holding down the 'SHIFT' key, and clicking on the selected columns. Additional arrows will then be numbered in consecutive order.

List Export				
	Interpret ↓	Jahr ↓	Album	Versi
239	MELANIE C	1999	NORTHERN STAR	
240	MELANIE C	1999	NORTHERN STAR	
241	MELANIE C	2000	MAXI	HEX
242	MERE	2000	THE ANNI I&I GER	

The list will now be sorted by column 1, and subsequently by column 2, and so on. Thus you can, for example sort a list by artist, and within the artist sort by release date. (See screenshot)

Modifying printout fonts:

Font...

The "FONT" button opens a window in which, windows compliant" font, style, size, and color can be selected.

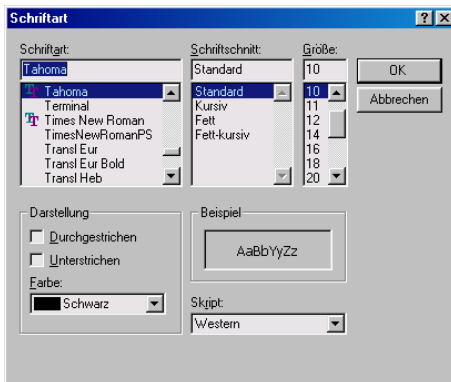

Exporting lists to file:

Export...

BPM Print Designer offers the ability to export lists in various formats for further processing with other programs. For a list of available file formats see screenshot. In the dialog box file name, and target folder are entered. The pulldown menu determines the file format.

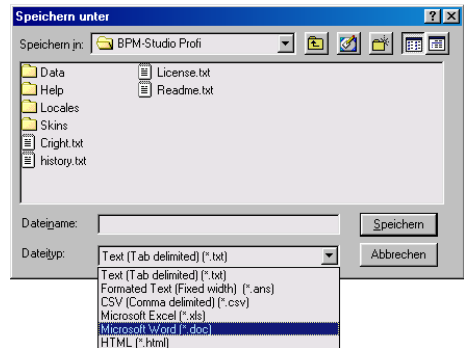

Print preview:

Preview

The "PREVIEW" button allows you to switch between the main screens column view, and the print preview. When in preview mode, more features are available to finish the document. Also a zoom function is available.

Exiting BPM Print Designer:

Close

The [EXIT] button exits the module. All made adjustments, and modifications in the Print Designers options will be stored, and available at next start. This makes it easy to print different categories in the same design.



Print & Export

Setup << < > >> Page 1 of 2 Zoom In Zoom Out Zoom 50% Print...

Page 1 of 2

News 2001

Serial	Title	Album	Number	Date	Genre	Type	Time
1	INSTRUMENTAL	BEHOLD THE PUPPETS	0000	2000	TRANCE	MP3	3:51
2	LOVE TRIP	LOVE TRIP	0000	2000	TRANCE	MP3	3:27
3	TRIP	PARADISE TO THE HEAVEN	0000	2000	TRANCE	MP3	3:02
4	WARRIOR FOR	TOP FOR WARRIOR	0000	2000	TRANCE	MP3	6:30
5	LOVE & GENTLE	THE LOVE & GENTLE	0000	2000	TRANCE	MP3	3:03
6	LOVE & GENTLE	THE LOVE & GENTLE	0000	2000	TRANCE	MP3	3:51
7	INSTRUMENTAL	WARRIOR TRIP	0000	2000	TRANCE	MP3	3:27
8	INSTRUMENTAL	LOVE TRIP	0000	2000	TRANCE	MP3	3:02
9	LOVE TRIP	LOVE TRIP	0000	2000	TRANCE	MP3	3:27
10	INSTRUMENTAL	LOVE TRIP	0000	2000	TRANCE	MP3	3:27
11	INSTRUMENTAL	LOVE TRIP	0000	2000	TRANCE	MP3	3:27
12	INSTRUMENTAL	LOVE TRIP	0000	2000	TRANCE	MP3	3:27
13	INSTRUMENTAL	LOVE TRIP	0000	2000	TRANCE	MP3	3:27
14	INSTRUMENTAL	LOVE TRIP	0000	2000	TRANCE	MP3	3:27
15	INSTRUMENTAL	LOVE TRIP	0000	2000	TRANCE	MP3	3:27
16	INSTRUMENTAL	LOVE TRIP	0000	2000	TRANCE	MP3	3:27
17	INSTRUMENTAL	LOVE TRIP	0000	2000	TRANCE	MP3	3:27
18	INSTRUMENTAL	LOVE TRIP	0000	2000	TRANCE	MP3	3:27
19	INSTRUMENTAL	LOVE TRIP	0000	2000	TRANCE	MP3	3:27
20	INSTRUMENTAL	LOVE TRIP	0000	2000	TRANCE	MP3	3:27
21	INSTRUMENTAL	LOVE TRIP	0000	2000	TRANCE	MP3	3:27
22	INSTRUMENTAL	LOVE TRIP	0000	2000	TRANCE	MP3	3:27
23	INSTRUMENTAL	LOVE TRIP	0000	2000	TRANCE	MP3	3:27
24	INSTRUMENTAL	LOVE TRIP	0000	2000	TRANCE	MP3	3:27
25	INSTRUMENTAL	LOVE TRIP	0000	2000	TRANCE	MP3	3:27
26	INSTRUMENTAL	LOVE TRIP	0000	2000	TRANCE	MP3	3:27
27	INSTRUMENTAL	LOVE TRIP	0000	2000	TRANCE	MP3	3:27
28	INSTRUMENTAL	LOVE TRIP	0000	2000	TRANCE	MP3	3:27
29	INSTRUMENTAL	LOVE TRIP	0000	2000	TRANCE	MP3	3:27

Sort by: None Columns: Number,Artist Autosize Multisort

Print... Back Close

3.16.3. Print preview window:

The print preview is used to manipulate the overall layout, and additional, useful information can be added to the list.

Page layout adjustment, and additional functions:

The "Settings" button opens a fourfold toolbox. Here, the following settings can be adjusted:

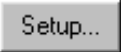

Zoom functions:

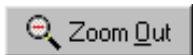

Downsize the view in steps

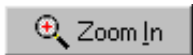

Enlarge the view in steps



Zooms on whole Page



Zooms to fit page width

Navigating within several print pages:



Jumps to first Page



Jumps to previous page



Jumps to next page



Jumps to last page

Register tab "Page":

Direction: Define if page is to be printed on as landscape or portray.

Page setup: Here the margins are defined. You have the possibility to choose a measurement unit of your choice.

Stretch: List will be adjusted to the overall page width.

Page | Layout | Header | Footer

Orientation
 Portrait Landscape

Page Setup

Left 15 Units
 Top 29 Mm
 Stretch
 Width 180 Cm
 Height 235 Inches



Register tab "Layout":

Show title

Select if a page title should be printed. The following fields you can enter a page title, and choose a font.

This button defines the justification of the page title. (Aligned left, aligned center, aligned right)

Show margins

Show margins in preview.

Show grid lines

Prints the lines between columns and rows of a list.

Register tab "Head row":

On this tab settings for the head rows of all pages are entered. Analog to this, on the forth register tab the footer settings are defined.

Show Header

Select this check box if a head row should be printed on every page. In the following fields, text and font for this head row can be entered.

This button defines the justification of the head row. (Aligned left, aligned center, aligned right)

Additionally to the regular text, four variables fields are available, which will be updated while printing

{PAGES} automatically adds page numbers
{NUMPAGES} adds the number of pages
{DATE} Adds the current date
{TIME} Adds current time

Show Header Line

Prints a line between the head row and the page title. In the following fields you can define color and width of this line.

Register tab "Footer":

On this tab the parameters for the footer are entered.

Show footer:

Select this check box if footer should be printed on every page. In the following fields, text and font for this footer can be entered.



This button defines the justification of the footer. (Aligned left, aligned center, aligned right)



Additionally to the regular text, 4 four variables fields are available, which will be updated while printing

- {PAGES} automatically adds page numbers
- {NUMPAGES} adds the number of pages
- {DATE} Adds the current date
- {TIME} Adds current time

Show Footer Line

Prints a line between the page content and the footer. In the following fields you can define color and width of this line.

Start printing:

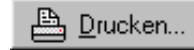

The "PRINT" key starts the print out. Before this though, you can enter how

many pages, and copies of the document you need.

The "Close" button will lead you back to the export



list window, in case you wish to make changes there.



If possible avoid printing and audio playback at the same time. If the selected printer should not be ready when the printout is started, the windows time-out may cause the playback to stop, and interrupt communication with the remote control unit.

3.17. BPM Studio Server Components

The BPM Studio server components are a universal interface to control the most software functions remotely. This functionality has been developed mainly to be able to cross platform with other programs. Since the interface is based on open standards though, control is available via standard protocols like HTTP or Telnet. This enables you to control different workstations (PCs with BPM Studio installed) that are located in different rooms. If the server component is activated (Register tab "Server" in Program Options) BPM Studio will establish an HTTP- and a Telnet-Server. The HTTP-server port and the Telnet port are freely configurable. Be aware though, that when controlling a component over

a network the reaction time on a released signal may be delayed.

Both servers make many important functions available via a command prompt or also as a URL.

Complete documentation is provided on the BPM Studio Webserver at <http://localhost:port/cmds.html>

Please have understanding for the fact that only limited support is available when implementing this interface, especially in very specific implementation cases.



3.18. BPM-Studio File Formats

This chapter is supposed to give you a better understanding of the file formats, and endings supported by BPM Studio. Some of them can be deleted, for others it is recommended to leave them on your hard drive.

***.grp, *.idx, *.gps, *.plg, *.lst:**

These files are used for the file- Play List archive. The *.gps, and *.idx files contain information about the structure of File- and Play List archive. For all titles in a major category of the File Archive, a [category name].grp file will be created containing all title information for this category. The Play List categories can be found in the *.plg files, and the Play Lists are stored as *.lst files. These are compatible with the directly store- and loadable Play Lists.

eq.eqp:

File for equalizer presets

Bpm.set:

Encrypted file for user information

***.bml, colors.cfg:**

This file contains the skins for BPM Studio. The bitmaps are contained in the *.bml files, colors are defined in the file colors.cfg.

***.cut:**

The cut format is available in the editors export function. In this case it is not the marked area that will be saved, but the Cue-Points, and marker information as links. Information that would otherwise only be available in the Play List or the file archive can be backed up separately this way.

***.~*:**

Tilde files are created automatically as back ups of all files of File- and Play List Archive. (Either when exiting the program, or, when auto save is active, every 15 minutes.

***.scn:**

Scan files will be created when needed by BPM Studio to position exactly in VBR files or very long MP3 files. They should not be deleted for:

- 1.) The Cue-Points will not be restored correctly since BPM Studio can't jump to the exact position, which can cause a "jump" after addressing the Cue-Point.
- 2.) The *.scn files in auto play mode would have to be generated anew, to determine the actual length of the title.

***.mem:**

Files for the saved files for the sampler functions of all files. (A.B.Exit-Loop)

***.cue:**

Files for the Cue-Points of each file.

*.mem and *.cue files can be deleted. Of course all Cue-Points of a loop will be lost, it still can be useful to clean up every once in a while though

***.sdd:**

Files for the peak files of the wave editor. They serve the editor in navigating in, and loading of files. These files can be deleted, the loading will take longer though.



3.19. Program Options

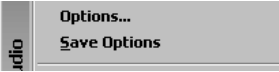

From any given pop up menu via options, the programs basic settings can be opened. These are split in 8 different areas, which can be selected on the 8 different register tabs.

- Options** - General settings
- Audio I/O** – Sound card configuration
- Storing** – Defining directories
- CDDA-Copy** – Adjusting CD parameters
- CD-Writer** – Settings for CD-Recorder
- Remote Control Unit** – Configuring the remote control unit
- User** – User administration
- Server** – Server components configuration

Presets – Language and Internet options

3.19.1 Preset – Language and Internet options

Language Pack:

Select here your language preference. Should your language not yet be supported by BPM Studio you can, provided you're interested, order our SDK language pack, and create a translation for your language.

Skin Pack:

Here you can select a skin. The list will display all available skins compatible with this version of BPM Studio installed in the folder ...\BPM Studio\Skins\. The download area of the ALCATech website, information about new or updated skins can be obtained.

Pitch Range:

Defines the pitch area for sliders. This value will be overwritten when clicking on one of the three pitch area buttons. (see also 3.2./ player)

Bend Speed:

Defines the pitch bend area

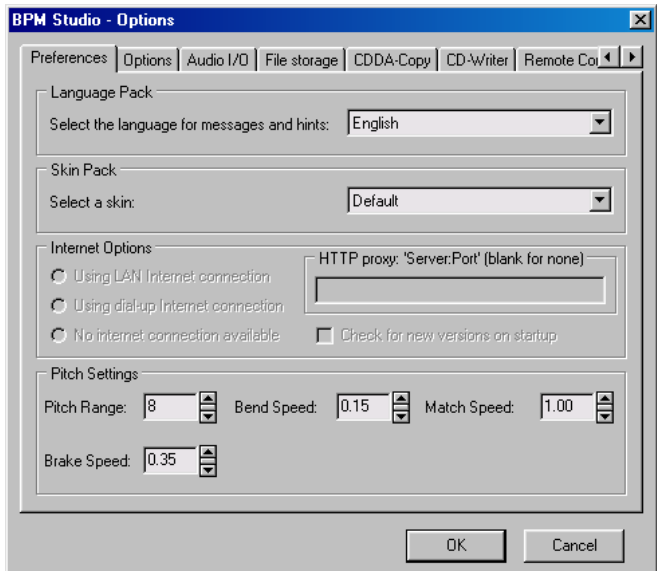

Match Speed:

Defines the time for BPM match

Brake Speed:

Defines the time for the Brake function

Navigation:

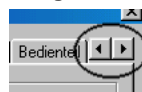

Not all register tabs will be shown, use these buttons to navigate back and forth



3.19.2. Options – General Settings

Load Wave Files

Scans for WAVE files at program starts, and loads such files

Load Sub Directories

Program will load all subsequent directories of a selected folder

Soft Pitch and Bend Changes

Allows for smooth operation of the sliders, and simulates the inertia of a vinyl album when using pitch bend.

Double Click loads Player

When double clicking a title in a Play List it will not be loaded into the preview player, but into the main player.

Ask before loading a player

Performs a security inquiry before the next title will be loaded

Reload File in Single Play Mode

If Single Play is activated, the current track will be repeated on end

Blink Display before file is done

10 sec. prior to the end of the current title, the display will blink in red.

Use Normalization if file is normalized

When check box is activated the settings of the normalized audio file will be used; otherwise they will be disregarded.

Use Silence Detection in AutoPlay

When activated, possible silence at the end of the title will be skipped. This is done to

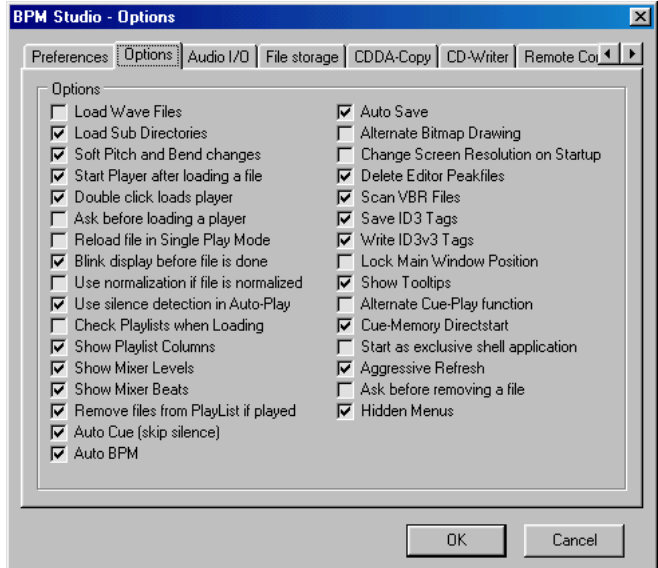

optimize title transitions in auto fade mode. This function will only work properly, if the title has been edited with the normalize function from version 4 on.

Check Play Lists when loading

When loading a Play List, presence of all list titles on the hard drive will be confirmed.

Show Playlist Columns

Shows vertical lines in head rows, and Explorer

Show Mixer Levels

Activates level indicator in Mixer. (Requires some system resources)

Show Mixer beats

Activates beat indicator in Mixer

Remove Files from Playlist if played

The title will automatically removed from the Play List, once played.



Auto Cue (Skip Silence)

Possible silence at the beginning of the title will be skipped

Auto BPM

Activates the automatic beat counter in the payers

Auto Save

All settings and the state of the file archive will be stored every 15 minutes

Alternate Bitmap Drawing

Use this option if you experience problems with your display, for example the slider look distorted.

Change Screen Resoluituin on Startup

At program start, the windows monitor resolution will automatically be set to 800x600

Delete Editor Peakfiles

At program end the peak files generated by **File Editor** will be deleted.

Scan VBR files

Activate this checkbox to enable exact positioning in files with variable bit rates

Save ID3 tags

This program modifies the ID3 tag of the original MP3 File

Write ID3v3 tags

The program writes the ID3 tag with the version 3. (It will not be accessible by older MP3 players anymore)

Lock Main Window Position

The position of the program's main window on the screen will be locked

Show Tooltips

Activates the "hints" function (Requires some system resource)

Alternatue Cue-Play function

With this function activated, the player will play as long as the CUP button is held. Once released, the player will jump back to the Cue-Point.

Cue-Memory Directstart

Upon clicking a DirectCue button the player will immediately be started with the Cue-Point, res. with the stored loop. When this checkbox is not selected, and the player is in pause res. cue, Cue-Points will merely be loaded into the player and will not start until the **[PLAY/PAUSE]** res. the **[EXIT/LOOP]** button is clicked. If the player is on, in any case a DirectCue button will start the title

Start as exclusive shell application

With this function, BPM Studio will be the exclusive application under Windows. Upon activating, a reset will be initiated, after which BPM Studio will be the exclusive application.

Aggressive refresh

This option causes a quicker display of the level indicator, the spectrum analyzer, and the title scrolling. On systems of lesser performance system resources can be freed, by deactivating this mode.

Ask before removing a file

When activated, a confirmation will be required before a title is removed from the player

Hidden menus

This option causes all pop up menus to be reduced to the important functions. The complete menu can be viewed though by clicking on the last entry. If this is not selected, all entries will be shown.

Create Data Backup

If this checkbox is selected, BPM Studio creates a backup of the current File- and Playlist Archive at each startup. By this way the last 10 program startups are stored. Those backup files can be used for restore by the Backup Function. The files are located in the program folder under Data/ Backup.



3.19.3. Audio I/O- Configuring the Sound Card

Driver

Here the device driver is selected (Direct Sound), WAVE, ASIO, EASI, or Kernel driver), the settings of the ASIO driver can be configured right here.

Monitor

Defines on which sound card, res. which channel the preview player output will be assigned

Player A, Player B, Sampler, CD-Player:

Via the pull down menu every device can have a sound card res. a stereo channel of multi channel sound card assigned.

Below the selected output channel the actual latency time of the according driver is indicated

Buffer Size

Defines the size of the WAVE Out buffer. The higher the value, the higher the program stability. It takes a little bit longer to write into the buffer though, which can be noticed by short delays when switching from Cue to Play, and back

Preload Size

Size of the internal playback buffer. Manipulate this value if you experience dropouts during playing, or the players don't start clean.

Auto-Cue Level

Here the trigger level for the auto cue function (skip silence at title beginning) can be defined. This value can be set from -inf (absolute silence) to -30 dB (a quiet level).

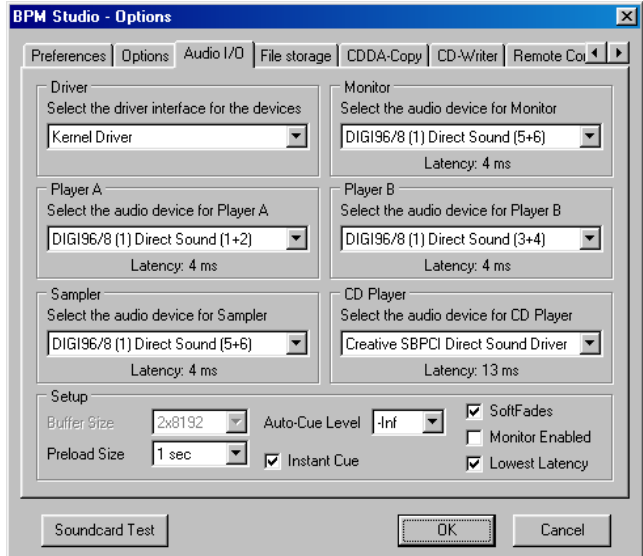

Soft Fades

BPM Studio fades all audio signals in, and out, smoothly before any audio title or cue. Thus it prevents possible disturbing noises / crackling.

Use Monitor

Activates the mixer monitor-function of the sound card/s. Prior to activating, the **sound card test** needs to be performed.

Lowest Latency

The Kernel Driver operates with a very small buffer, and shortest latency times. Deactivate this function if you experience playback difficulties, or drop outs with your sound card.

Soundkarten Test

Starts the sound card test. More information is provided in the **Monitor-Functions**



Latency Setup

(Only if Kernel Driver has been selected) Opens the dialog for latency adjustment:

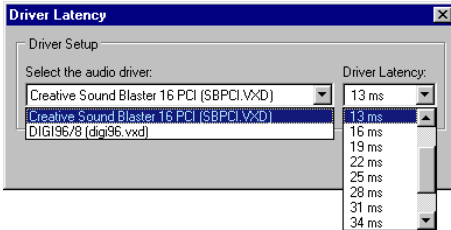

Select the audio driver:
Select the driver to modify

Driver Latency

Here you can manipulate the driver's latency times. For a minimal delay between a button being pushed, and the reaction of the sound card; meaning, for a rapid response of the Cue-, Play-, and Direct Cue buttons and Loop functions, this value should be kept as small as possible. Only increase this value if you experience problems with playback.

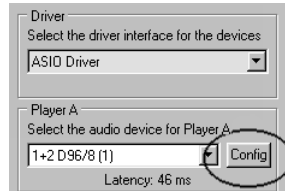

ASIO-Driver settings

(Only if ASIO driver is selected) With the config buttons, located beside the pulldown menus of the virtual devices you can access the ASIO Driver settings for a particular device.

Please refer also to chapter 2.5 / Adjusting audio parameters!



3.19.4. Storing - Defining directories

Default Search Directory

In this folder all relevant application data will be stored. That for example would be the default Play Lists, the categories, and subcategories of the File Archive, Sample-Block information, the equalizer presets, and the CDDB title information of previously read in CDs. It is recommended not to change this folder. If you want to access this file archive from another version of BPM Studio, the folder needs to open to “file sharing”

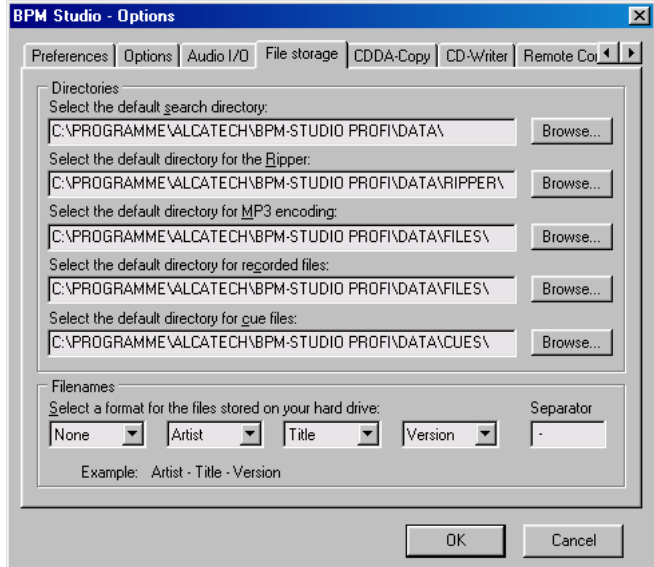

Directory for the Ripper

In this folder the WAVE files to be compressed will be stored temporarily. This path can lead to another, bigger hard drive. For example if you would like to rip several CDs first and then encode them in one process. (See also CDDA options – copying, encoding)

Directory for MP3 encoding

In this folders the MP3 files will be stored after compression. It is recommended to create a separate folder (e.g. C:\MP3) in which all titles will be stored. This will make it easy to upgrade the system later on with additional hard drives. BPM Studio automatically scans all logical drives for present titles, if the original path should not be present anymore.

Directory for recorded files

Default folder for WAVE- and MP3 files for the Recorder. If an extended mix is to be recorded in WAVE format, the file can easily exceed several GBs. For this, you can specify another folder on another hard drive.

Filename

Here the filename, which later on will be generated by programs, will be defined. It is recommended to keep default values.

In case you have a large file archive of already present files without ID3 tags, and want to read it into BPM Studio, you can change the assignment temporarily.

The possible adjustments on this register tab are of increasing importance when user administration, and network functionality become involved. Please refer to the according chapters in the manual, for more information.



3.19.5. CDDA Copy Defining CDDA- and compression parameters

Block Count

Number of blocks on a media, that will be read if the CD-ROM drive is accessed.

Read CD Text Infos

Audio CDs that have text on them, will be read (will not work with older Audio CDs, or on older CD ROM drives

Force Generic (NT)

Activate this option if you are having problems under Windows NT with a possibly loaded ASPI driver

Encode during Copy

Select this option if you want to read in audio CDs directly and convert them into MP3s, without temporarily storing them.

Otherwise the ripper module will merely write files in the WAVE format, and copy them to their prospective folder. The conversion into the MP3 format will then be done in the encoder mode of the CD player / ripper.

CDDB Server

Here you can define the desired CDDB server. With a click on "GET LIST" the mirror server list will be loaded, and then the desired mirror server can be selected. When having problems with cddb.cddb.com try freecddb.freecddb.org.

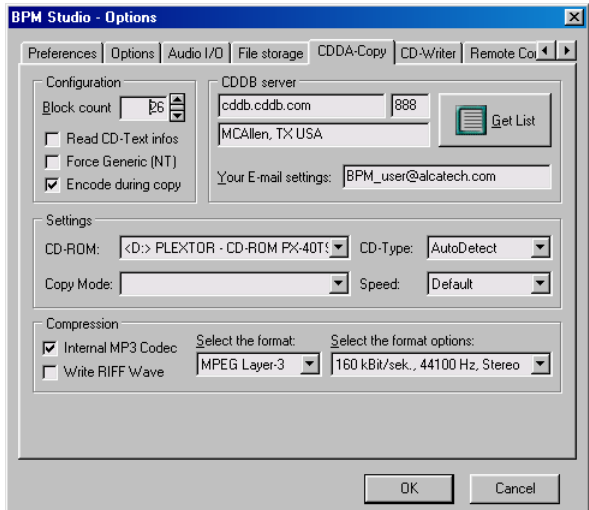

Your email settings

To register with a CDDB server, your email address is required

CD-ROM

Select here the CD-ROM drive, for which adjustments are to be made.

Copy Mode: Burst Copy

Read and write access will be performed simultaneously

Copy Mode: Normal

Alternating read and write access will be performed

Copy Mode: Sector synchronization

In this mode an exact repositioning of the reader head is guaranteed in case the information flow should be interrupted. This is the safest mode, but also the slowest copy method.

**CD Type**

Here you can select out of the list of your CD-ROM drives. This setting is only necessary when you are experiencing problems while reading in CDs, and "AutoDetect" does not solve the problem.

 Internal MP3 Code

When encoding, BPM Studio's own internal code is used (Recommended). If additional codes are installed on your PC, they can also be selected here.

 Write RIFF Wave

Writes a MP3-Wave-File, that is compressed, but can still be played on most Windows players.

Format

This selection field shows all audio compression codes available on a system. The BPM Studio's own supplied MPEG Layer 3.

Format Options

Here the quality of the compression is defined. (Depending on file format). It should be at least a 128 kBit/s, 44,100 Khz stereo.



3.19.6. CD Writer Adjusting Recorder Parameters

CD-ROM

Select a Recorder out of a list of all Recorders available in the system. The following six checkboxes indicate which functions are supported by the selected Recorder. Functions not supported by the selected Recorder will be displayed in gray. (Inactive)

Speed

Here the burner speed is defined. MAX adjusts the speed to the maximum possible on the selected Recorder. Decrease the speed if you frequently receive errors caused by the performance of your system, or the used media.

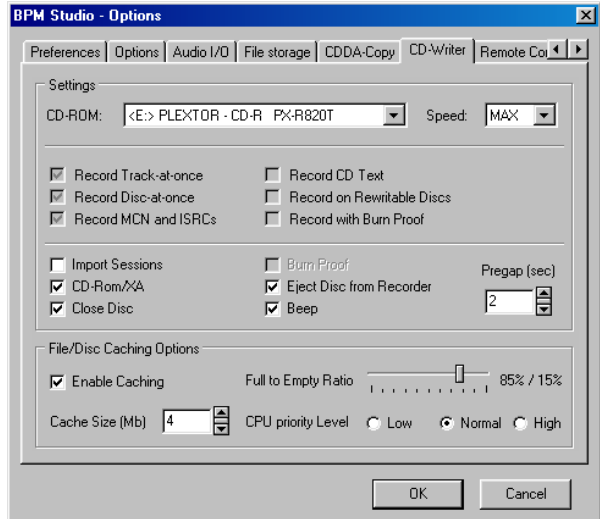

Record Track-at-once

Track-at-once (TAO) is a writing method that for once (similar to disc-at-once) burns single session discs, and for the other (mainly) can be used to create multi session discs – which would actually not be able with DAO per definition. With TAO the laser will be switched off after writing each particular track, moved to the PMA to update the temporary table of contents, repositioned to the end point of the previously burned track, and switched back on to continue.

Record Disc-at-once

Disc at Once is the writing method of choice when creating professional Audio-CDs and masters for commercial mass production. With this method a CD will be burned within one single session, and then closed. The laser writes without interruption the Lead-in with the table of contents, all tracks, and eventually the Lead-out. (This explains why a unusable through write interruption disc appears to be containing all tracks, even if the mistake occurred during the first track. The table of contents has been written first, thus the player “thinks” the listed tracks are really on the media.)

Record MCN and ISRCs

The ISRC-Code (“International Standard Recording Code”) identifies a recording (in general this means a track). In principal therefor every track of a CD should have a ISRC code, which identifies it uniquely. This protocol is only mastered by newer CD burners.

Record CD Text

A procedure developed by Sony® and Phillips®. With CD text audio players of the newest generation are capable of displaying name of artist, name of current title, and even annotations. The information of the ID3 tag will be added onto the media, if the Recorder supports this function

Example of CD-ROM drives capable of reading out CD-Text*:

- Plextor PX-40TS (SCSI)
- Sony CD-ROM CDU 711 (SCSI)
- Teac CD-524-EA-B (IDE)
- Teac CD-532-E-A (IDE)
- Teac CD-532-E-B (IDE)
- Teac CD-540 (IDE)



Following CD Recorders are currently capable to read and write CD-Text*:

- Teac 56S/58S later than Firmware 1.0j (SCSI)
- Plexwriter 4220 later than Firmware 1.02 (SCSI)
- Plexwriter 8220 (SCSI)
- Ricoh 7040 later than Firmware 1.20 (SCSI & ATAPI)
- Ricoh 7060 later than Firmware 1.20 (SCSI & ATAPI)
- Sony 948S later than Firmware 1.0h (SCSI)
- Sony CDX 100 / 110 / 120 / 130 / 140 / 145
- HP 8100 / 8110 / 8200 / 8210 / 9100 / 9110 (Same vendor as Sony)

To find regular CD players capable of reading CD-Text, visit your local consumer electronics store.

Record on Rewriteable Discs

The Recorder supports writing on CD-RWs. Media that can be reused.

Record with Burn Proof

Burn Proof is a procedure developed by Sanyo® in which throughout the whole process of burning the Recorder's internal buffer is monitored. When system performance becomes slow, or even critical, the drive notices that a buffer underrun is unavoidable – and stops the burning procedure at a suitable location. This gives the buffer time to reload, the data is compared and synchronized, and the writing process continues right after where it stopped. This averts the media to become unusable, if the data throughput should be interrupted again.

Import Sessions

Sessions already present on the CD will be imported, the CD may not be finished though. Select this option if you want to write more data on a multi session CD. Important! When writing on a multi session CD without activated import, all previous sessions will be destroyed.

CD-ROM/XA

The CD-ROM/XA is a mixture of the specifications for CD-I, CD-ROM mode 2, and the current format for data CDs. Deactivate this option if you are having problems reading in the CDs created with BPM Studio. Some older CD-ROM drives do not support this format. When writing multi session CDs, this format is a requirement in most recorders.

Close Disc

Finalizes the CD after the burn procedure. Older CD-ROM drives can not read Data-CDs if they are not finalized. Audio CDs will always be finalized in general, since here it is not possible to write on the CD in several sessions.

Burn Proof

Activates the burn proof function of the recorder. (if any) Buffer underrun errors will be averted, and the burn process will be faster.

Eject Disc from Recorder

If this option is selected, the tray of the drive will automatically be opened when the burning process is complete.

Test Mode

When in test mode, writing will only be simulated. All functions of a "real" burn will be performed, with the exception that the laser is switched off. Thus the media will not be changed or damaged. This mode is used for troubleshooting, to avoid to many plain media will turn out as scrap. Keep the function "Eject Disc from Recorder" activated, since many Recorders only allow another recording on the same media if it has been removed, put back into the device, and scanned back in anew.

* no Guarantee



Pregap (sec)

Here define the pause between tracks of a audio CD. For data CDs this function is obsolete.

File / Disc Caching

By using File / Disc caching, buffer underrun errors are mostly history. Also it allows for a more efficient use of the processor and other system reasources.

File/Disc Caching Options

Enable Caching

Enables File/Disc Caching

Cache Size (MB)

Select cache size in MB. (Minimum is 1MB, max. is 32MB)

Recommended cache sizes depending on available RAM:

<i>RAM</i>	<i>Rec. Cache Size</i>
64MB	2 to 4 MB
128MB	4 to 8 MB
256MB	8 to 16 MB

Please do not exceed the maximum cache size. This could cause performance to decrease even more, than it would without activated caching

Full to Empty Ratio (%)

Setting of data size to be read in, before the cache has to be refilled. If the ratio is 86% to 15% for example, the cache will be filled to a 100%, and after 15% of the data have been purged, refilled to a 100% again. (This cycle will be repeated, until no data to be cached is present anymore.) It has been proofed that this method is more efficient than trying to keep the cache filled to a 100% at any given time.

CPU priority Level

Selects the processor priority level of the cache process. For 99% of all systems the "normal" setting can be maintained.

A very extensive and clearly arranged documentation about CD-Rs, CD-RWs, Recorder, and file formats can be found at <http://www.disc4you.de/kompendien/cd/>

Please pay attention also to troubleshooting hints in chapter 3.15. CD Player / CD Writer of this Manual!



3.19.7. Remote Control Configuring external control units

On this register tab the connected control units will be adjusted to your needs. Depending on how deployed, (local PC / DJ Case, portable PC, or notebook) hardware outfit (number of sound cards, hardware audio outfit), and type of remote control unit, different functions can be assigned to the sliders, and multi purpose buttons. The level of adjustability depends on the type of the connected remote control unit. Additional information can be found in the chapters of each particular unit.

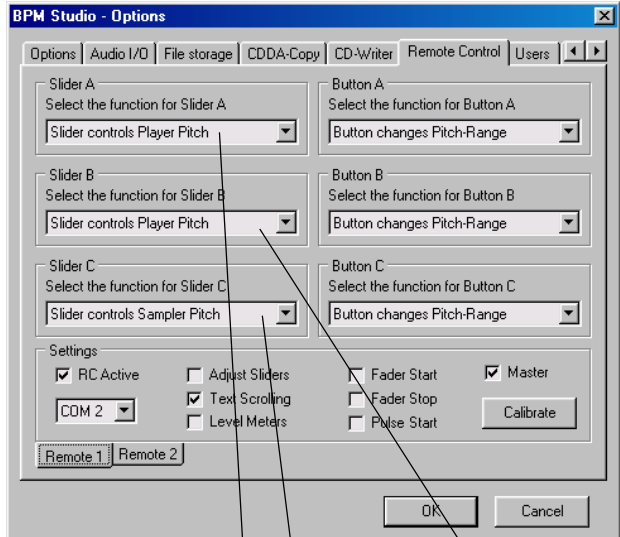

Connecting 2 remote control units:

BPM Studio PRO can be operated with two remote control units simultaneously. Thus, the same system can be accessed from two different rooms. For each control unit separate options are available, like COM port, etc. Of course very control unit needs it's own serial port. The two tabs to the lower left you can select options for control units 1 and 2:



When using two control units with sliders, one of them must always be dedicated as master

Master, the sliders of the other unit will stay inactive. When combining a unit with sliders with a unit with pitch wheels, only sliders will work. The pitch wheels of the other unit will be disabled. When combining two units with pitch wheels, no restrictions apply, therefore this solution should be preferred.

RC Active

Should always be enabled at the connected remote control unit. If so, the program will check on start up if the unit is connected, and operational.

Available control units can freely be combined with each other. Although, under certain circumstances, restrictions can arise from the fact that the sliders on the control units can not be automatically used.



Selecting a COM port:

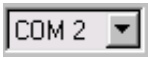

Defines on which port the unit will be connected during the initial installation.

Slider A, Slider B

Select here which functions you wish to assign to the sliders of the two players. (Not with RCP-2001-B).

Slider C

(Only RC V3) is the slider of the sample player. Three functions are available: Sampler Pitch, Sampler Volume, and Manual Fade A/B. When setting as manual fader, crossfades between player A, and player B can be performed even without external mixer.

Switches A, B, C

Define here the functions of the multi purpose buttons of the two players. (Only RC V3) These settings also apply for the two players in the program!

Adjust Sliders

Activate this option when you have problems with the sliders. (Only RC V3)

Text Scrolling

Activates title scrolling in display (Needs some system resource)

Level Meters

(only RC V3) Shows level indicator in RC display. (Uses some system resource)

Fader Start

Activate this checkbox if a external mixer is connected to the fader start socket [36] or [37], and the players should be started automatically when blending in a particular channel (Only RCP-1001 / 2001)

Fader Stop

Activate this checkbox if a external mixer is connected to the fader start socket [36] or [37], and the players should be stopped automatically when blending in a particular channel. Should this checkbox stay activated, the players will keep playing, even if the mixer controls are pulled down. (Only RCP-1001 / 2001)

Pulse Start

Activate this option if you would like to use the pulse start socket of the remote control unit. (Only RCP-1001 / 2001)

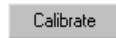

(only RC V3) With this button the remote control unit sliders are calibrated. To do so place the 3 sliders into their center position and click on CALIBRATE. The slider position will be defined to 0.



3.19.8.

User Administration

A detailed description of these features can be found at a later point in this manual later.

With the user administration, several users can work in the same system at different times, without influencing each other. Each user has his own program settings, for example play lists, file archives, skin (program appearance), Program Options, or the assignment of virtual devices to particular sound card channels. Further all modules can be activated/deactivated, user specifically. Each user can have his own File Archive, or access the (write protected) Master Archive.

The user administration is activated by creating the first new user, or by creating a password for the administrator. From this point on a password inquiry will be performed at any every program start. The password field can also be left blank though.

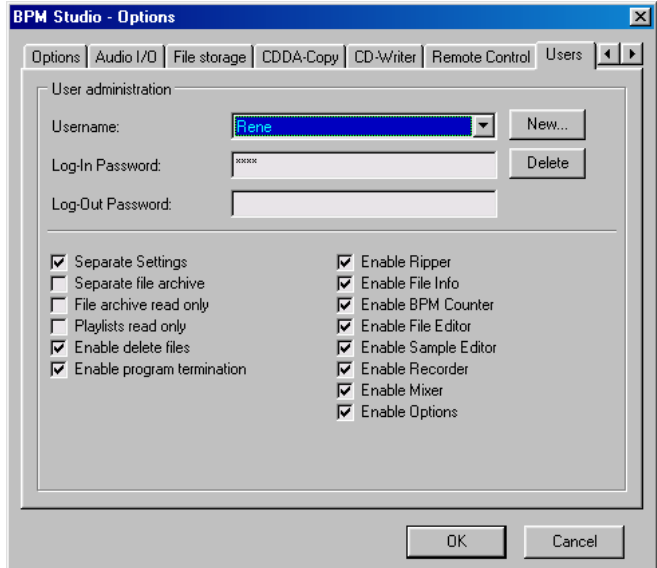

Separate Settings

Settings for this user will be administrated separately in the Program Options

Seperate File Archive

User obtains own File Archive

File Archive read only

The user is not authorized to change the file archive (with no regards on if he has his own archive, or uses the administrators)

Playlists read only

User can not save play lists

Enable delete files

User is authorized to use "Delete file from harddisk"

Enable program termination

The user is authorized to close BPM Studio (if inactive, the administrator password is required)

Enable Ripper/Encoder up to Enable Encoder

Here BPM Studio modules can be activated, res. deactivated for this user.

Enable Options

User is authorized to change Program Options (regardless on if he uses his own, or the system administrators.



3.19.9.

Server components

Further informations about this feature can be found in the chapter BPM Studio Server Components.

The server components of BPM Studio offer functions that allow to remotely control the program via Web-Browser, or Telnet. On this register tab the most important parameters for both servers are defined. We recommend maintaining the preset settings, as long as they do not cause conflicts with other PCs or Servers in the network.

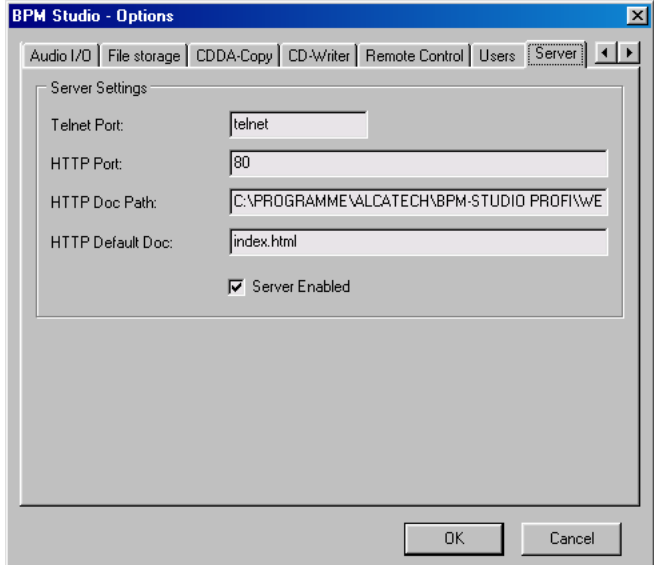

Telnet Port:

Here the port number for the Telnet server is defined. Default is 23

HTTP Port:

Here the port number for the HTTP Server is defined. Default is 80. If the server is active, access to the PC with a web browser is possible. This is done, in the best case scenario, by entering http:// -followed by the IP address of the computer.

If access is to be gained on the same computer, on which the program is installed, you can enter "localhost" instead of the IP address.

HTTP Doc path:

The HTTP server will make this folder as main directory publicly available. It can contain proprietary information, e.g. web pages with control functions for BPM Studio

HTTP Default Doc:

Define the file that will be displayed as start page if the user enters merely the IP address of the computer into his browser, without specifying a particular file.

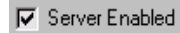

If this checkbox is selected, both servers will be activated and BPM Studio is accessible, and can be controlled from every PC connected to the network. Provided appropriate measurements have not been taken against this.



3.20. Additional Functions

3.20.1. Normalize Function

Via the pop up menu in File Archive and the different play lists, the normalize-function can be activated. Use this function if a title playback is either too loud, or too quiet. If you activate this function in the categories window, all titles present on the system will be normalized. With large archives this procedure can take several days (!), therefore must only be applied to a title once. If new titles are added, this function will be applied, already normalized titles will not be scanned again though, which speeds up the procedure considerably.

During normalization the Peak- and RMS Values of all titles are determined, and a average value for the titles volume is calculated. Upon this the loudest and most quiet title are known, and based on these values titles will be adjusted later on. Very quiet titles will be amplified, and very loud ones will be reduced in their volume. The dynamic mostly stays unchanged, since only one amplification factor is applied and no dynamic adjustment.

3.20.2. Search Dialog

The search dialog is also accessible via the pop up menu in BPM File Archive or the  button in the file lists. Here you can perform your search according to the following search criteria: BPM range, artist, title, title version and album. The search term or text string will always be compared exactly with the list entries. But you can also use

wildcards. Here some examples: WEST* will find all titles with WESTBAM, WESTERNHAGEN, etc. *HAGEN will find all titles like WESTERNHAGEN, NINA HAGEN, etc.

EN finds all titles containing an EN, e.g. DEN HARROW, or X-PERIENCE.

If the search was successful, a new folder SEARCH RESULTS will be created in **BPM File Archive** in which the search results will be listed. If this folder should exists already, all files in it will be overwritten.

3.20.3. Monitor Functions

For professional use of BPM Studio the monitor functions are essential. While a title in **Player A**, **B**, the **Sample Player** or the **CD Player** is played over the PA System, it is possible to listen to, or prescreen any other given external or internal signal source via headphone to e.g. screen titles, place Cue-Points, determinate the BPMs of a particular title, or equal out BPMs. The basic requirement for this is at least one additional sound card, or multiple channel sound card, to assign the monitor channels if BPM Studio to a dedicated audio channel.

The monitor functions have to be enabled in the **Program Options** on the register tab Audio I/O. In the monitor area, a dedicated sound card will be assigned to the monitor channel. The following virtual devices utilize the monitor channel:

- All **Preview-Players** in the **Play Lists** and the **BPM File Archive**
- The preview player of the **BPM Counter**
- The monitor switch in the main program
- The monitor buttons in the **Mixer**



The volume of the monitor channel is adjusted with the MONITOR control, in the **Mixer**



Before the monitor functions can be used a sound card test, and synchronization need to be performed. Otherwise differing sample frequencies would cause runtime differences between monitor channel and player when playing. To synchronize sound cards proceed as follows:

First select the desired driver. (Synchronization is necessary with Direct Sound, WAVE, and KERNEL driver.)

Then click on the button "Test Sound Card". Each Sound Card will now be tested for 1 min. BPM Studio then analyzes the results, and synchronizes the Sound Cards. This test needs to be performed separately for WAVE and Direct Sound Driver, if both are to be used.

3.20.4. The Program internal BPM Database

BPM Studio disposes over it's own database, in which the BPM values of all titles are stored. A basic supply of BPM values is included. Additional titles will be added through the **File Info Box**, or the **BPM Counter**.

Whenever you add a new title to the system, the program checks if a BPM value is already available, and assigns it to the file.

If a new MP3 file is loaded, that has a BPM Value in it's ID3 tag already, then this tag will be adopted into the internal BPM database. If a value is already determined for this title, it will be updated.

3.20.5. The PreAmp-Function (Limiter)

Within the equalizer the PreAmp function can be activated. This is recommended if the red "OVERFLOW" LED stays on permanently. This means the overall amplification is to high, which may cause distortions.

3.20.5. The back-up- and Update functions

Via the pop up menus of the Group window and the File Archive you can access the BackUp and Update function.

The **back up Function** allows you to create a backup copy of the entire File Archive in a predefined folder. From there it can be restored later on. With this method a copy of the File Archive can be transferred to another PC also.

The **Update-Function** offers two options.

"Search Hard Drive" scans the entire system, including all connected network drives for playable titles, and lists them under NEW FILES + date.

"Update Archive" removes all titles no longer present out of the File Archive, and lists all new titles in the NEW FILES category.

3.20.7. Interface for Visualization Plugins

Via the Recorder pop up menu the interface for WinAMP Visualization Plugins can be activated.

In a list, the in the folder \BPM Studio\Studio\Plugin installed plugins are listed. Some of these plugins can be configured within the range of their functions. To do so, click on the button "Configure" and make the desired adjustments. To compensate for resource problems the "Priority" control is uses. ALCATech GmbH does not guarantee that BPM Studio will work with these Plugins.



More information about current sound card tests, program updates, and answers to frequently asked questions can be found on our website www.alcatech.de



3.21. User Administration

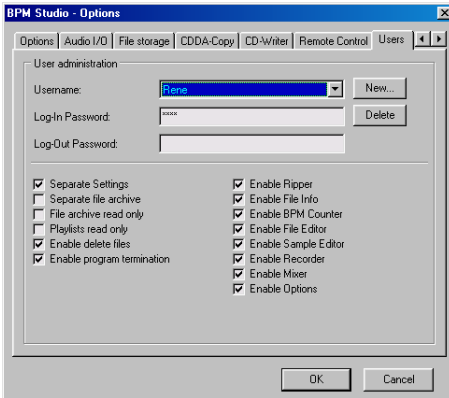

3.21.1. In General

This section explains the work method of the BPM Studio user administration. Example configurations can be found at the end. The user administration enables different users to work at the same system independently. Additionally it is possible to assign different levels of access. Especially when more than one version of BPM Studio is in use in a network environment, the network functions and the user administration develop a synergistic effect and offer extensive administration possibilities. Please see also "Network functions".

Activating the User Administration

To activate the user administration either a new user is created with the "NEW" button, or a password is defined for the system administrator. From this point on, a username and password inquiry is performed whenever the program is started. The password can be omitted.

Defining Login and Logout passwords

In the "Login password" and "Logout" fields the passwords for program start, end exiting the program are defined. A password for exiting the program is usually not necessary though. If the field is left blank, no inquiry will be performed when exiting

Switching the active (logged in) users

Only exiting, and restarting BPM Studio can switch the active user. At the new program start, the other username needs to be selected.

3.21.2. User specific settings

The "User" register tab is divided into the global settings for a selected user, (left column), and the access restrictions for the BPM Studio modules (right column).

Separate Settings

When this checkbox is activated, all settings on the 6 register tabs in the Program Options will be stored separately. This can be done if the user logs on under his user name, and then defines his own settings in the Program Options. This is only possible though, if the "Options" Checkbox, in the right column of the user administration, is selected. This offers the opportunity that the user adjusts these settings once (or the administrator logged on under the users name), and the administrator then locks access to the Program Options.

Other possible utilization is to serve different sound card settings. (Channel assignment or flexible configurations / notebook installations)



Separate File Archive

When this checkbox is marked off, a own File Archive will be created for this user. The user can configure this archive independently from the Master File Archive (which is maintained by the administrator) to his liking. If so though, he is responsible for backups, and actualization. For this the File Archive Function in the group windows pop up menu can be used.

In network installations the users archive can be stored also on the server, or the Master File Archive of this server will be displayed for this user (read only). See also **Network-Functions**. If this is the case, the user can store his file archive also on the server. Or the Master File Archive can be displayed for this user. (Read only)

File Archive read only

This option is pretty much self-explanatory. If this checkbox is marked, the user will not be able to make modifications to the File Archive. This relates to the category structure, and play lists in these categories. Modifications to the titles themselves (in the ID3 tags) will be granted though.

(If this is to be avoided, either the modules "BPM Counter" and "File properties" need to be disabled, or the checkboxes "write ID3 tags" and "save ID3Vs tags" need to be deselected.)

Play Lists read only

This checkbox deactivates the "SAVE LIST" button within all play-lists. This avoids lists being saved, or present lists to be overwritten. The user will only be able to access prepared play lists, he can change them while the program is running. Saving modifications at the end of the session is not possible though.

Enable delete files

This checkbox activates the pop up menu option of File Archive and Play Lists to delete files from the hard drive. When deactivated, files can merely be removed out of the Play List and the File Archive. To deactivate this option can be helpful to avoid accidental file deleting.

Enable program termination

If this checkbox is selected, the logged on user can close BPM Studio. If previously a log out password has been defined it will be required though.

If this checkbox is not marked, the administrator password is required to exit BPM Studio. If BPM Studio has been defined as exclusive shell application, and the PC is not accessible, this way it can be avoided that user gains unauthorized access to the system.

Checkboxes " Ripper" to " Mixer"

Here the different modules are activated / deactivated for a particular user

Enable Options

When selected, the user is authorized to modify the Program Options.



If a Master File Archive is accessible through the network, access will always be granted on a "read only" basis, even if "File Archive read only" checkbox is not selected.



If the "Separate Settings" checkbox is not selected, the user will have access to the same options as the system administrator.



3.21.3. Example Configurations

A given PC is used by the system administrator (e.g. the dance club owner) and two DJs. The owner keeps the File Archive current, and frequently adds new titles. Both DJs work with those titles available on the system. DJ 1 merely uses the File Archive provided by the owner, DJ 2 has created his own File Archive, and updates it himself. Both DJs work independently at different times.



If you upgrade from BPM Studio Home to BPM Studio Pro, the settings of the use administration will not be automatically adopted. If so, please specify the old folder during the installation. Read also the more extensive explanation in the Update instructions.

=selected, =not selected, !=necessary, *=recommendable, .=irrelevant)

DJ 1:

- * Separate Settings
- ! Separate File Archive
- * File Archive read only
- . Playlists read only
- * Enable delete files
- . Enable Program termination

- * Ripper
- . File Info
- . BPM Counter
- . File Editor
- . Sample Editor
- . Recorder
- . Mixer

- * Options

DJ 2:

- ! Separate Settings
- ! Separate File Archive
- ! File Archive read only
- . Playlists read only
- * Enable delete files
- . Enable Program termination

- * Ripper
- . File Info
- . BPM Counter
- . File Editor
- . Sample Editor
- . Recorder
- . Mixer

- * Options



3.22. Network Functions

This part explains the extended network functions of BPM Studio.

The first two subchapters separately explain the different functions. Following, different examples of application and example configurations are described. Since the network functions strongly interact with the user administration, it is recommended to consult the **User Administration** in your studies. Deploying BPM Studio in a network basically has the objective of serving MP3 files to clients from a central server, res. a client that also shares this task. Additionally, network wide access to file archives is possible.

3.22.1 Addressing MP3 Files

You can install BPM Studio on several client PCs, and then use a shared pool of MP3 files, which is basically a requirement when working with network file archives. Although we recommend the use of a 100Mbit network, but also 10Mbit networks of up to 5 clients are known to run smoothly. The folder /s with the MP3 files will be shared on the server PC. On the client PCs access can now be gained either over a network drive (recommended), or via the network client of Windows98.

Addressing MP3 files via the Drive letter

This form of addressing is predefined in the Program Options logical drive letter assignment on the "Storing" register tab. It is also a requirement for correct functioning of the network functionality in general, and the "Update" function in the File Archive. Also when you add MP3 files to the File Archive using the "+FILE" or "+DIR", you usually select them via **Desktop\My Computer\[LW]:[Folder]**.

Addressing will follow the **LW:\[Folder]\[Subfolder]*.mp3** pattern

At the end of this page two example entries are shown. In the first section of the entry, the location of the files becomes obvious. Also, at initial program start, only logical drives, meaning local drives, and network drives will be scanned. A network drive can be connected in Windows Explorer -> connect network drive.

Addressing via drive letter:

Example entry in a *.grp-file of the File Archive
(Displayed with a word wrap, that is not present in the original file)

```
Track0=C:\PROGRAMME\ALCATECH\BPM-STUDIO PROF\DATA\A-HA - EARLY MORNING.MP3|TAG|A-HA|EARLY MORNING||HEADLINES||HEADLINES THE HITS OF A-HA|||OTHER|MP3|0|179696|0|327680|0|0|-1|0|0|0|3|128|7|-1|0|0|0|-1|||0|
```

Example entry in a Playlist
(Displayed with a word wrap, that is not present in the original file)

```
C:\MP3\EIFEL 65 - BLUE DABADI.MP3|TAG|EIFEL 65|BLUE DABADI|||HTTP://WWW.BPMSTUDIO.DE||MP3|0|221152|0|327680|0|0|-1|0|0|0|3|128|8|-1|0|0|0|1019794890|||0|
```



Addressing MP3 files via the computer name

If no network drives are supposed to be installed on a client PC, for example if the client PC is connected to particular servers only randomly, it is possible to access the files through the Windows network client. Here also the files or folders are loaded with +DIR or +FILE, but now via the network neighborhood of Windows, not "My Computer"

The address of the MP3 files will then be in form of `\\[Computer name][Folder][Subfolder]*.mp3`

An example of a File Archive row, in which the file is addressed via the computer name, can be found at the end of this page. In place of the drive letter here `\\HOLI` (the computer name) and the name of the shared folder `DATA1` are displayed. When using this method of addressing though, at every access a Windows name resolution needs to be performed, which can, under circumstances, lead to timing problems for example if the address of the WIN-S-Masterbrowser changes. Until now though, dropouts due to this addressing method are unheard of. Be also reminded though, that the BPM File Archive "Update" functions don't work correctly.

In mobile use with local server connectivity it is recommended, to create a user for every place of use, and then load the files via the network client.

3.22.2. Network File-Archives

A BPM File Archive consists of a group of text files located at the DATA folder of the particular BPM Studio installation. The files `Groups.gps` and `Groups.idx` contain the folder directory of the File Archive. The `*.grp` files, like `Default.grp`, contain the paths to the different MP3 files. These files can be located on a local drive, a connected network drive, or on a PC addressed via `\\[computer name]` See also addressing via computer name. With no regards to the type of the file archives, it is always the MP3 files provided by the central server that are actually accessed. In general one tells apart between a Master File Archive, and user file archives.

A Master File Archive will be provided by the server, and is only editable from there. It can be viewed on the clients in read only mode. Any given user can use this File Archive, without having to worry about updating or maintenance. This will be the network administrator's task.

A user file archive can be created on the client PCs or, similar to the Master File Archive, on the server. If the user file archive stored locally, there is no way to access it from another client PC. Modifications would have to be made by each particular user.

Addressing via the Network Client:

Example entry in a `*.grp`-file of the File Archive

(Displayed with a word wrap, that is not present in the original file)

```
Track620=\\HOLI\DATA1\MP3\RUBRIKEN\HOUSEWATERGATE - MADE OF
ORLEANS.MP3|TAG|WATERGATE|MADE OF ORLEANS||DREAM DANCE - VOL.13 - DISC
1|||MP3|0|230400|0|327680|0|0|-1|0|0|0|3|128|8|-1|0|0|0|-1|||0|
```



For this reason it is possible to store the user file archives on the server. This way the user can find his own, current archive on every client PC. All these settings can be adjusted in the user administration on the "Storing" register tab. What type of network file archives actually will be used, depends on the type of network, number of users, maintenance strategy, and other local circumstances. In general it is recommended to analyze these facts before the installation, and to coordinate with the network operator.

Creating a Master File Archive

When initially installing BPM Studio on the server (or the client PC that will later on provide server services) a default archive is created in the program folder under \DATA. This archive will not be deleted, even if new user accounts are created, and can be edited through the administrator account.

The path to this File Archive is defined in the Program Options-> file storage. Additionally the equalizer presets (eq.eqp), and the locally stored CDDDB (cdda.cdb) inquiry results are stored here. Also the default path to the encoded mp3 files is located here after the initial installation, which should at this point be modified to the shared folder for MP3 Files. (See also shared MP3 files)

To be able to access this File Archive from a BPM Studio client on another PC, some adjustments are necessary.

To begin with the folder \DATA in the BPM Studio directory must be unlocked in the file sharing options if Windows Explorer. *(There is also the possibility to grant access to the whole drive c: of the server PC, for security reasons this is not recommendable though).*

On the client PCs a new drive letter will be created, and assigned to the shared DATA folder. Afterwards, in the BPM Studio Program Options of the client PCs, the server PCs folder can be selected via this drive letter. When closing the Program Options, BPM Studio will now announce the presence of a File Archive, after a security inquiry, this Master File Archive will be displayed, instead of the user File Archive.

Protected Access of Network File Archives

To ensure that current information is available on all clients, BPM Studio has two background functions.

- 1.) The File Archive can only be edited on the server, and will be provided to the clients in read only mode. BPM Studio automatically detects if a File Archive is located on the server, or no a client.
- 2.) Each client inquires the server in short intervals for modifications of the file archive, and updates its own archive accordingly.

Title search function when loading

When several PCs use a shared File Archive, it can not be guaranteed that a MP3 file will be located under the same drive letter, although it will be in the same folder res. the same directory. Therefore BPM Studio scans all logical drives for a file when it is loaded. This is also useful on standalone platforms, when additional hard drives are added to the system. BPM Studio will automatically scan for the same directory under all other drive letter.



3.22.3. Example Configuration

With this example the work method of network functions are explained.

A dance club with 1 server in the office, and 2 clients in different areas. All DJs work with the same File Archive provided by the dance club, but can make their own BPM Studio settings and adjustments on the clients. Archiving of new CDs, and File Archive maintenance are done at the server.

Configuration:

The MP3 files and a Master File Archive are saved on the server. The servers access the File Archive, and the files in "read only" mode.

Server:

The server consists of a system drive C:\, two data drives D:\ and E:\, and a CD-ROM drive F:\. Reading in CDs is done locally in the office, which can be done during an event without any problems. To do so, the server needs to have W98, and a version of BPM Studio Home installed. The User Administration on the server will be unmodified. On drive C:\, the BPM Studio \DATA folder, drive D:\ and drive E:\, will be opened for file sharing.

Client:

The client PCs will be configured as follows:

System drive C:\,
W98, BPM Studio Home or Professional
Sound Card depending on intended purpose
CD-ROM drive D:\

Three network drives, connected with the server:
E:\ as the data directory of the server
F:\, G:\, with D:\ and E:\ of the server

Now, in BPM Studio, the data path will be modified from C:\program files\Alcatech\BPM Studio\DATA to the server (D:\, since this is the logical drive connected with the server's DATA folder). Thus the administrator of the client PC will hence use the Master File Archive. Modifications can from now on only be done on the server.

After a restart of BPM Studio the Master File Archive will be loaded from the server, and the client will automatically log on to the server. If a title of the file archive is selected, BPM Studio scans the two connected network-drives for this title, and loads it.

Expansion for multi user:

More users can be created on the client, which will have their own settings, and will also be able to store their own play lists, while still being able to access the Master File Archive. To do so, the two new users will get entries into the user administration, get passwords, and the according entries will be made. Additionally, the "File Archive Write Protected" function should be enabled.



4.1. Where can I get MP3 files?

BPM Studio will be delivered without any MP3 Files. Our systems are designed for you to copy your Audio CDs to your computers hard drive, and save them as MP3 Files. Thus you can be assured that there will be no loss in quality, and playability of the titles. But also the most MP3 titles from other systems, as well as MP2, and WAVE files can be played with BPM Studio. Step-by-step instructions on how to copy CDs, and creating a File Archive can be found in the First Steps chapter of this manual. You can also utilize other encoders from other vendors, be aware though, that quality differs between different encoders.

Lately, titles are offered for purchase in the MP3 file format already, these can usually used be with BPM Studio without problems.

Legal reminder:

BPM Studio may only be used to copy/encode titles if you are the author, or if the author, or a person owning the copyrights has authorized you to do so. Otherwise you take the risk that you make yourself liable to prosecution, res. to be held liable by the copyright owner. Please pay attention to laws and regulations regarding the use of MP3 files. You can inform yourself about these either with the regional office of the GEMA, or on the Internet at www.gema.de. If you use BPM Studio outside of Germany, please refer to the according institutions representing artist, and record company rights.

4.2. How can I play MP3 files?

BPM Studio offers two independent **Players** for playing MP3 files, which provide all functions of a professional double-CD-player for DJs.

A requirement to use BPM Studio that there are already MP3 files saved on a PC. These will be read in, and displayed in the **play lists**, at the first program start after the installation. The players will automatically play the play list in descending order.

1.) At any given time titles can be added to the

Play List by clicking the  button at left lower corner of the Play List The title selected in the **File Archive** will be added to the play list. If no title is selected, a Explorer window will open showing the directory of your hard drive(s). Select here the MP3 files to be inserted, and confirm with OK. The selected MP3 files will now be inserted into the play list.

2.) Load a given title out of a **Play List** or the **File Archive** into one of the two players by Drag&Drop. To do so, move the mouse pointer over the title, press the left mouse button, and hold it down. The mouse pointer will change into two little musical notes. Now move the mouse pointer over one of the two players, and let go of the button. The title will be loaded into the player, and the red LED display over the **[CUE]** button will come on. A click on the **[PLAY]** button starts the playback. Alternatively you can start the title via the remote control unit also. The buttons **[PLAY]** **[CUE]** on the computer screen are identical with the buttons **[4]** and **[5]** on the unit.

In the following chapter read how you can mix MP3 files with single beat accuracy, and use the players professionally. In the **Player** chapter of this manual you can find detailed descriptions of all player functions.



4.3. Beat Matching with BPM Studio

As when working with regular CD – players, single beat accurate mixing takes quite an amount of empathy and lots of practice. But to make the transition from CD to MP3 as easy as possible, the especially for BPM Studio developed remote control units and the extensive and versatile software allow you work with the same look & feel as with a high quality, conventional double CD player.

Single beat accurate mixing means a titles seamless transition into the next one, where the base beats of both titles can be heard simultaneously, but appear to be one. (3)

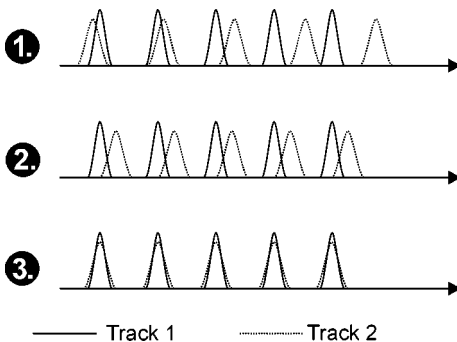







During this process both titles play simultaneously for a certain time, which allows to create various effects.

To achieve this it is necessary that both players play the titles at exactly the same speed. The BPM values (Beats per Minute) of both titles must be exactly equal. Also, the beats of both titles must be played simultaneously. (Beat synchronizing 3.). BPM Studio offers powerful tools to simplify beat matching. The real time BPM counter determines the BPM value of every title in real time. With the **[SET]** button **[21]** (also called BPM Match button) the BPM value of the other player (Master) is automatically adopted, and both title's speed is automatically equaled.*



Only remote control units with Pitch Controls:



When this process is executed the pitch LED **[25]**, and the pitch indicator in the equaled players display **[14f]** will blink. The adjusted player will maintain its pitch value, until you position the pitch control on the remote control unit to the value indicated by the software. Following the pitch value of the adjusted player can be manipulated from this position on again. (With the pitch wheel of the RCP-2001-B this value can be manipulated again immediately)

Quick description of single beat accurate mixing:

- 1.) Select two titles that somewhat correspond in style and speed. Load these titles into the two players, e.g. via Drag&Drop out of the File Archive. Now the BPM value for both titles will automatically be determined, and be indicated in the top right corner of the player's displays. (If this indicator shows PITCH, it can easily be switched to BPM by left clicking on it.
- 2.) Initially, move both pitch controls back to zero. To do so, right click on the slider scale of both pitch-controls.
- 3.) Activate speed control (Pitch) with the  button. The green pitch LED should now be on in both players.
- 4.) In player B click on the BPM match button () , and observe the BPM indicator. The BPM value of player A should be adopted. If this is not the case, then the difference between the two speeds is too small for the currently selected pitch range. By clicking on the  or  button select a larger range, and try again to adjust by clicking on the  oder  button. (The BPM Match button is also available at the remote control units.)



- 5.) When the BPM values in both players are equal, the titles are played with the same speed. You can ensure this, if you start Player B, and screen with headphones simultaneously to Player A.
- 6.) Now prepare the second title to be mixed in, by setting a Cue Point directly in front of a beat. To do so start the player B with headphones.
- 7.) Stop player B at approximately the first beat of a new bar. BPM Studio will from now on remember this point a Cue Point
- 8.) Now start player A, and try to start player B at a beat of player A. You can try this several times by not stopping player B with the Play/Pause button, but with the Cue button. Thus the player will return to the stored point, and will start from there on again. Should the two titles not be approximately synchronized, the Cue Point needs to be corrected as follows.
- 9.) Click one of the search buttons  or  smartly. The player is now in loop mode, and frequently repeats 160ms of the title from the Cue Point on. Through clicking these two buttons again (or with the jog shuttle dial at the remote control unit) you can now move this Cue Point forward, and backwards, within the title. By screening the title through headphones, and by observing the spectrum analyzer in the player's display, you can place the Cue Point exactly on the beginning of the beat. The loop mode will be ended by clicking the Cue- or Play button, and made adjustments will be adopted. When the Cue Point is placed so accurate that you can start player B approximately simultaneously with player A, not until then the title is prepared for accurate beat mixing.

- 10.) Now you can start player B simultaneously to a beat of player A by clicking the  button. Player B will now play approximately synchronous to player A.
- 11.) Now you can shortly slow down, or accelerate the player B with the  and  buttons, and compare by headphones when the beats will be exactly synchronous. If you discover that the titles become asynchronous after a little while, simply adjust the pitch value with the according control in the smallest, possible increments. For this the pitch wheel of the RCP-2001-B remote control unit is especially suitable.



After BPM equalizing with the **[SET]** button the adjusted player will block the use of RC's Sliders. As soon as you position the pitch slider of the locked player to its true position at the remote control unit, the block will be removed, and thus the pitch value can be modified again, e.g. to make slight corrections. The PITCH indicator on the remote control unit will blink when blocked, and will show the difference between remote control unit slider, and real position of the slider, which simplifies positioning the remote control unit slider to its real position.

- 12.) From now on there are no limits to your imagination when it comes to working with the two synchronously playing titles. Alternate between the two players by beat or by bar with the manual fader, kill frequencies at the external mixer, or just play both titles parallel.



4.4. How do I work with Playlists?

BPM Studio saves the title order in the play lists below the two players. The player will now play those titles in the order of this list.

You can modify this list to your liking, add titles, delete titles, rearrange the title order, or save the list for further use. It is also possible to enter a title a couple of times repeatedly, or in different positions on the list. All modifications made to the list, (for example with the File Editor) will be stored, and will be available when loading this list again.

In the Play List Archive you will manage all your play lists conveniently and you can even copy parts of one play list into another, or load complete lists into the player. During this process only the title information get modified, the MP3 files themselves will stay at their location.

#	Artist	Title	BPM	Time
1.	NO MERCY	WHERE DO YOU GO O	127	7:29
2.	PEARL	THE NEVERENDING S	132	3:38
3.	VANILLA ICE	ICE ICE BABY 2001	137	6:30
4.	VOODOO & SERANO	BLOOD IS PUMPIN	137	4:59
5.	DUSTY SPRINGFIELD	IN PRIVATE	130	4:15
6.	SPARKS	WHEN DO I GET TO SI	123	3:51
7.	GIGI AGOSTINO	ILL FLY WITH YOU	138	7:59
8.	YORK	FAREWELL TO THE M	138	9:09
9.	HIGHLAND	SOLO TU	123	3:42
10.	TRAN-SIZTA	ON THE RADIO	140	3:30

CLEAR LIST LOAD LIST SAVE LIST + FILE - FILE SEL ALL FILE INF TOTAL: 1:41:45

This part of the manual only covers handling of single play lists. Read in the File- / Play List Archives what possibilities you have when archiving play lists.

4.4.1. Adding titles to a play list

- 1.) Click on the  button, in the bottom left corner of the play list. The title selected from the **File Archive** will now be inserted into the play list at the predefined spot. If no title is selected, a Explorer window will open showing the root directory of your hard drive/s.
- 2.) Now select the MP3 files to be inserted, and click OK to confirm. The selected titles will be inserted into the play list.



You can also pull complete play lists or categories from the File- and Play List archive into a play list. The titles will be added. Pull a complete play list, or category on a player, and the old list will be replaced with the new one.

4.4.2. Modifying the title order

Via Drag&Drop the order of titles can be modified. Click on a title, and drag it to another position within the list. A little red arrow to the left in the list simplifies sorting in.



4.4.3. Storing a Play List

Click on **SAVE LIST**. An Explorer window will open in which you can specify a name, and a folder for the play list to be saved. OK confirms, and the play list will be stored under this name.



You can also store the complete Play List in the Play List Archive, by dragging and dropping it on the group window. Upon doing so, you can renamed the newly created list.

4.4.6. Adding a play list to the archive

Click into the head row of a play list window of a player, and hold the mouse button down.

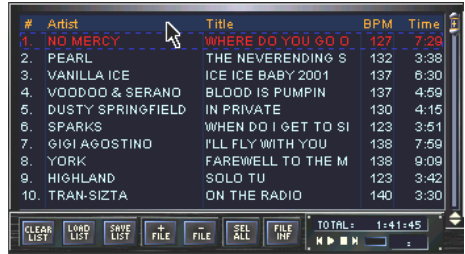

You can also store the complete Play List in the Play List Archive, by dragging and dropping it on the group window. Upon doing so, you can renamed the newly created list.

Now drag the play list into the group window of the Play List Archive. There, a list symbol will appear beside the mouse pointer.

4.4.4. Loading a Play List from Hard Drive

Click on **LOAD LIST**. A Explorer window will open, from which you can load BPM Studio play lists (*.pls), as well as other formats like for example WinAMP play lists. The previously loaded list will be lost though.



4.4.5. Drag&Drop functionality of Play Lists

BPM Studio offers various functions to conveniently assemble, load, and archive play lists. A central position in this functionality is presented by the Play List Archive. Here, the play lists can be stored in freely definable categories. Also, the play list history is located here. Switch

Drop the play list by letting go of the mouse button, it will now be added to the archive under the name PLAYLIST. Now choose [rename] in the pop up menu of this entry, and define a name that makes sense for this list. You can also sort this new list into another category by Drag&Drop, or move it freely within the group window.

to the play list archive by clicking the **LISTS** button. The left window will now display the different play list categories, and the right window (title list) will show the titles within a category selected to the left.



4.4.7. Loading a Play List from the Archive into a Player

In the group window of the Play List Archive click on the list to be loaded, and hold down the mouse button. A note symbol will appear beside the mouse pointer.



Now drag the selected play list on the desired player. Drop the list by letting go of the mouse button. This play list will now be loaded into the player, and the previous one will be replaced. Read how to amend, or insert a play list onto or into a already present list in the next chapter.

4.4.8. Merging a Play List to an already loaded List

Scroll to the end of the play list window of the desired player. In the group window of the Play List Archive click on the list to be loaded with the left mouse button, and hold it. A little note symbol appears beside the mouse pointer. Now drag the play list to the last title of the loaded play list, and drop it below. The new play list will be amended to the one already loaded.



You can also insert the new play list at any other desired spot within the loaded play list. The little red arrow to the left of the list simplifies this.

4.4.9. Adding title sequences of a play list to an already loaded list

In the group window select the desired play list containing the titles to be added. Then mark the desired titles by clicking right into the title window. By holding the [Ctrl] key down, you can select and deselect multiple titles. When all desired songs are selected, click on one of the selected titles, and drag the whole block into the play list window of the player, and drop them.



You can also, as when loading complete play lists, drag the selected titles directly on the player. Thus the selected titles will be loaded into the player, and the previous play list will be discarded.

4.4.10. Screening titles

With the preview player in the lower right hand corner of the play lists you can screen marked titles, without having to load them into a player.



The preview player of the File Archive can also be controlled with the Sample Player keys <, 0, and > of the remote control unit. 0 stops and starts the player, < and > are used for rewind and fast forward.

In chapter 3.3 all functions of the play list are extensively explained



4.5. Creating Fades between Titles

The Cross-Fader enables automatic fades between the two players. Every single title of the play list can have a different fade assigned. Thus the fade can be adjusted exactly to the particular title.

- 1.) Screen the end of the title to be faded, and select a point from which on you wish to start fading out. Before doing so, switch the time indicator to REMAIN so you can observe the remaining playtime of the title.
- 2.) Adopt the remaining playtime of the title into the cross fader as fade time. To do so, adjust the FADE TIME control accordingly.
- 3.) Now pick up the end of the level curve of the title to be faded, by clicking the left mouse button on it.



The mouse pointer changes into a bi-directional arrow.



Move the end of the curve into the lower right hand corner of the cross fader display.



Now the last seconds of the title to be faded will be displayed in the cross fader's display. The time will also be displayed.

The title will be faded out in accordance with the adjusted level curve. If this curve is set like in this picture, the cross fader will start fading out slowly at half of the set fade time.

By moving the start point of the fade curve you can adjust the time, in which the title will be faded out.

If you move the point all the way to the right for example, then the title will be played with the full volume all the way to the end.



If the start point of the curve is set all the way to the left, a slow, and continuous decrease of volume until the end of the title will be applied.



But also any other desired fade pattern can be adjusted by Drag&Drop.



Assigning a fade to a title

When all adjustments have been made in the cross fader, the prepared fade needs to be assigned to the according title.



This is also accomplished by Drag&Drop. To do so, click on an empty spot within the cross fader display.

Drag the adjusted fade to the title in the play list, which it is to be assigned to. The mouse pointer will have a little cross fader symbol accompanying it:

#	Interpret	Titel	BPM	Zeit
1.	BOB SINCLAIR	I FEEL FOR YOU		4:22
2.	SPILLER	GROOVEJET		3:36
3.	DJ TONKA	DONT BE AFRAID	2.58	
4.	AVENIDA	CHANGE		3:45
5.	BOB SINCLAIR	I FEEL FOR YOU		4:22
6.	LOST N ALIVE	FUNKY PEOPLE	1.46	
7.	AFRO MEDUSA	PASILDA		3:24
8.	DJ BOBBY	TRANQUILITY MEGA	1.12	3:38

Once the fade is assigned, this title will be marked with a little rectangle in front of the time column of the play list:

#	Interpret	Titel	BPM	Zeit
1.	BOB SINCLAIR	I FEEL FOR YOU		4:22
2.	SPILLER	GROOVEJET		3:36
3.	DJ TONKA	DONT BE AFRAID		2:58
4.	AVENIDA	CHANGE		3:45
5.	BOB SINCLAIR	I FEEL FOR YOU		4:22
6.	LOST N ALIVE	FUNKY PEOPLE		1:46
7.	AFRO MEDUSA	PASILDA		3:24
8.	DJ BOBBY	TRANQUILITY MEGA		3:38

All following titles in the play list, will now have the same fade assigned, until another fade is assigned to one of the following titles. If an already assigned fade needs to be modified, the modified fade needs to be reassigned via Drag&Drop to confirm. This avoids unwanted modifications on previously assigned fades.

The Automatic-Mode will be switched on and off with **AUTO**. Only when automatic-mode is active, will the assigned fades be applied.

All functions will be explained extensively in the Cross Fader Chapter.



4.6. How can I change title information?

BPM Studio offers convenient options on how the informations attached to a title are managed. These informations are stored in the ID3 tags of the files themselves, and in the play list files (*.pls)

- 1.) Point the mouse pointer on the title to be modified.
- 2.) With the right mouse button / pop up menu select the "Properties" point. Alternatively you can also use the  button.
- 3.) The **File Info Box** will be opened:



Here all information contained in the ID3 tag will be displayed. If you want to modify any of the information, simply overwrite it, and confirm with OK. The information will be updated in the ID3 tag, as well as in the **Play List**.

To the right of the BPM field, the complete path to this MP3 file will be displayed. If there is not enough space, you can move the mouse pointer over it, and the whole path will be displayed as tool tip.

The "MORE" button will only appear if the selected file is a CD-at-once track. Read the **CD-Player** / CD-at-once chapter for further explanations.

With the BPM... button you can open the BPM Counter module, and be able to determine the BPM value directly out of the properties dialog, and save it.

Edit... will start the **File Editor** with the selected title.

In the chapter File Properties Dialog you can find further information and descriptions about modifying title information.

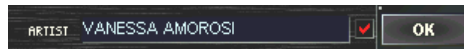

When you select several files, and open the File Properties Dialog, a checkbox will appear beside every entry. If this checkbox is marked, the modification in the according field will be applied to all titles. This is especially useful if several titles are to be assigned to a particular genre, or album title.



4.7. Ripping and Archiving Audio-CDs

BPM Studio does not only provide the means to professionally play and mix titles. Also many functions and perfected modules are available for copying and archiving audio-CDs. How you can transfer your existing CD collection to the BPM Studio system, is explained in the following section.

Requirements:

Music in the MP3 format occupies about 1 MB of hard drive space for 1 minute of music. This means that on a hard drive with 30 GB capacity approximately 8,000 to 10,000 titles with an average length of 3.5 minutes can be stored. The Audio-CDs are read in with the CD-ROM drive and copied to the hard drive. This procedure is also called "ripping". The speed of this process mainly depends on the quality of the drive. But also the performance of the overall system is important, for example if copying and encoding are to be done in one single process.

After the installation of BPM Studio, MP3 files will be stored in the \DATA folder on drive C by default. We recommend, when using the program professionally, to install a second (or even more) additional hard drive/s, and to move the MP3 folder accordingly to the new hard drive. This can be done in the **Program Options**, "storage" register tab.

Optimally create a MP3 folder on the new hard drive, and select this folder as standard for MP3 files. BPM Studio will then store all ripped, and encoded files in this folder.

A large relief, when adopting title lists on the PC, is the global CD database on the Internet. There, the title information of the most known and current CDs are stored, and can be downloaded for free. BPM Studio has a built in CDDDB inquiry function,

to be started over the  button. If a particular CD can not be found in this database, an alternative CDDDB-database can be defined in the Program Options. Or, the information can be entered manually in the file properties dialog. To be able to use the CDDDB inquiry you need a Internet connection either over the dial up network adapter of Windows, or through a real Internet connection through a masked network. Standard Proxy software for Windows only offers HTTP and FTP services. If you own a UNIX system as gateway, activate masquerading, and enter the IP Address of the gateway into the network settings of Windows. If you use programs like WinGate, or AVM KEN!, please activate the SOCKS Proxy in these programs, res. install the proper client software on the BPM Studio PC. You can get more help from about this topic from your system administrator, or your local PC store.



We recommend to save all MP3 files in one folder. The BPM Studio File Archive and the hard drive directory stand in no relation to each other. If you move a file in the BPM Studio File Archive, the physical location on the hard drive remains unchanged. This way, it can get messy very easily, if you store files in different folders on your hard drive, and later on rearrange them in the File Archive.



Ripping Audio-CDs:

1.) Switch to the CD-Player of BPM Studio by clicking the **RIPPER** button. Insert a audio-CD into the CD-ROM drive. After a couple of seconds, all titles on the CD should appear in the players Play List. Since BPM Studio doesn't know this CD yet, all titles will be displayed as TRACK – followed by their title number.

2.) Now click on the **CDDB** button. Provided Windows has a Internet connection set up, the PC will log on to the Internet, connects to the CDDB (central disc data base for audio-CDs) and try's to retrieve the information for the CD in the drive.



3.) After successful CDDB query all titles of the CD will be listed.

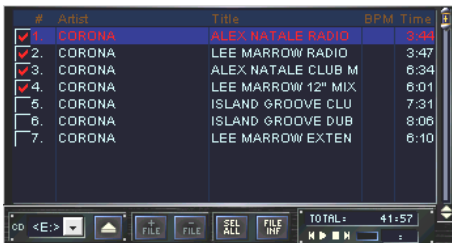

If no information was provided in the CDDB for this particular CD, at this point enter them manually, in the file properties dialog. Now mark the titles to be read in with the according checkbox

to their left in the list, and click on **COPY**. All marked titles will now be read in. The progress will be displayed in a status window.

After successful encoding all files will automatically listed in the File Archive's "NEW FILES" category. For clearer appearance a subfolder with the current date will be created. (See also screen shot at end of page)

In the chapter CD Player you can read up more functions available for convenient audio-CD read in BPM Studio. You can, for example, read in whole CDs as one track, or retrieve the CD information for several CDs with one single CDDB query.

Creating a own File Archive:

BPM Studio can manage several ten thousands of titles. At such vast numbers, it is easy to loose track, if titles are not assigned to different general categories. For this purpose the File Archive is used. In the screen shot to the side you can see an example structure of an archive of this kind. It consists of a number of categories, and sub categories that can be opened and closed by double click.



After the initial installation or after reading in CDs you'll find new titles here that can be assigned to categories according to your preference.

The archive shown here consists of the following categories:

#	FILE	TITLE	TYPE	YEAR	BPM	TIME
1.	AQUA	BARBIE GIRL	MP3		130 BPM	3:17
2.	AQUA	GOOD MORNING SUNSHINE	MP3			4:04
3.	AQUA	HAPPY BOYS & GIRLS	MP3			3:37

**NEW FILES:**

This category will automatically be created by the ripper, whenever new CDs are read in. The date, of when the CD was ripped, will be used as sub category. In this sub category you will then find all the titles that have been read in at this particular day.

FIND RESULTS:

This category will be created from BPM Studio after the initial installation, when all hard drives are scanned for MP3 files. This category will contain sub categories, sorted by drive letter, in which all found MP3 files will be located.

DEFAULT:

If you do not wish to make further modifications in different categories res. subcategories, you can sort in all titles here. Otherwise just leave the groups empty. This particular group/category is necessary for BPM Studio to work properly, and can not be deleted.

**Drag&Drop out of the group window:**

You can drag a whole group out of the group window (to the left in File Archive or Play List Archive), and drop it on a player. The previous play list will then be replaced with the new titles. If you drag the titles into a play list, they will all be amended to this list.

ARTIST:

This category is created individually. As sub categories, different artists are defined. In one of these sub categories all titles of a certain artist present on the system are listed. This is very useful if you have a lot of titles from one particular artist, or whole albums are intended to be saved together. The sub category MIKE OLDFIELD for example contains a second branch sub category called TUBULAR BELLS, in which all titles of this particular album are saved.

TIME:

This also individually created category utilizes different times as sub directories. Here titles are saved for which not the artist, but the release date is used as index.

Of course these are only examples. Every user should create a File Archive according to his own needs, and in the for him most overviewable fashion, so it can be browsed quickly during events.

Independent of the File Archive structure, it is recommended to use the search function, to find a particular title.

Read in the File- and Play List Archive chapter about even more functions available in BPM Studio for archiving titles. You can, for example not only archive files, but whole Play Lists, in which the order of titles will also contain all fades.



4.8. How do I use the Sampler most efficient?



With the sampler of BPM Studio you can load short jingles, loops, and sound effects, and then replay them by the click of a button. The maximum length of such a sample in BPM Studio LE is 20 seconds. As in the two players the playback will start exactly when the sampler button is clicked. This is achieved by utilizing very fast Direct Sound drivers, or the Kernel Driver

developed by ALCATech. Learn now, how you can load and play samples with the sample player.

- 1.) Look up a jingle in your **Play Lists**. (You can also use a regular title, merely 20 seconds will be loaded in the sampler though.)
- 2.) Drag the title onto the desired button of the sampler, e.g. **2**. To do so, place your mouse pointer over the title, push the left mouse button and hold it down, while you point at the desired button with the pointer now. The n let go. The sampler LED will shortly change its color from green to red, thus indicating that the sample has been loaded. When the sample is loaded completely, the digit on the Sampler Button will become brighter, this making it easier to determine which buttons have samples assigned.

- 3.) Now click on the sampler button. The sample will be played. For the duration of the sample playback can be stopped, by clicking the same button again (not in scratch mode). You can also start the sample with the number block on your PCs keyboard or with the sample block of the remote control unit (not RCP-1001). These buttons work parallel

Through the pop up menu two different playback modes can be selected for the sample player.

4.8.1. Single Play:

When this option is activated (a little check mark can be seen in front of the entry) a possible still playing other sample will b stopped. Only ONE sample will be played at a time.



You can also load a sample directly from the hard drive, via the pop up menu. To do so point on the desired button, and click the right mouse button. In the appearing menu select "Load", and select the desired file in the Explorer window popping up. Confirm with OK.

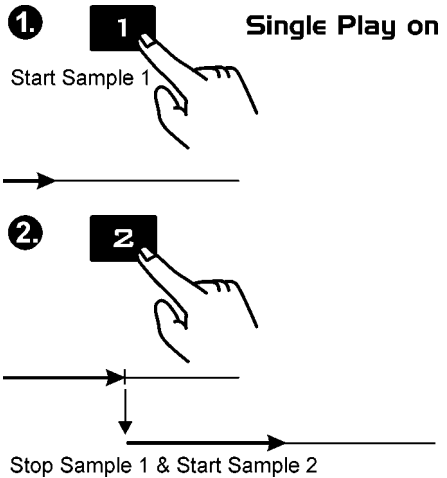



1. 1 Single Play off

Start Sample 1

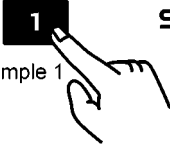

2. 2

Start Sample 2

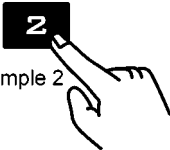

Play Sample 1 & Sample 2

Scratch Modus off

(Sampler-LED [29] lights green)

1. 2 Start Sample

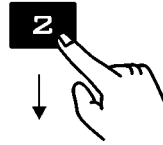

2. (press anew while sample is playing)

2 Stop Sample

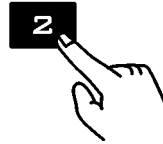

4.8.2. Scratch mode:

When this option is activated (a little check mark can be seen in front of the entry), upon clicking the same button again the sample will not be stopped, but restarted. With this function a sample can for example be played repeatedly to the beat of the title.

The volume of the sample player can be adjusted at the two **[VOLUME]** controls. Also the speed of the sample player, (Pitch) can be manipulated:



Scratch Modus on
(Sampler-LED [29] lights orange)

1. 2 Start Sample

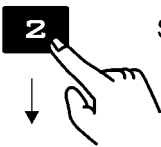

2. (press anew)

2 Restart Sample

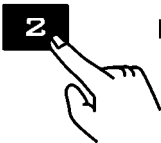

4.8.3. Configuring the Sample Player:

BPM Studio supports output of the different devices, through different sound card channels. If not enough channels are available though the sample player can share the two output channels of player A and B. In Program Options, register tab Audio I/O, simply the same channel as for player A, is entered for the sample player. When using BPM Studio, the assignment keys

und are used to select if the output is combined with that of player A or B. Please be aware that shifting the title takes a couple of seconds. This will also be indicated by the sampler LED, when turns green again, the sampler is ready.

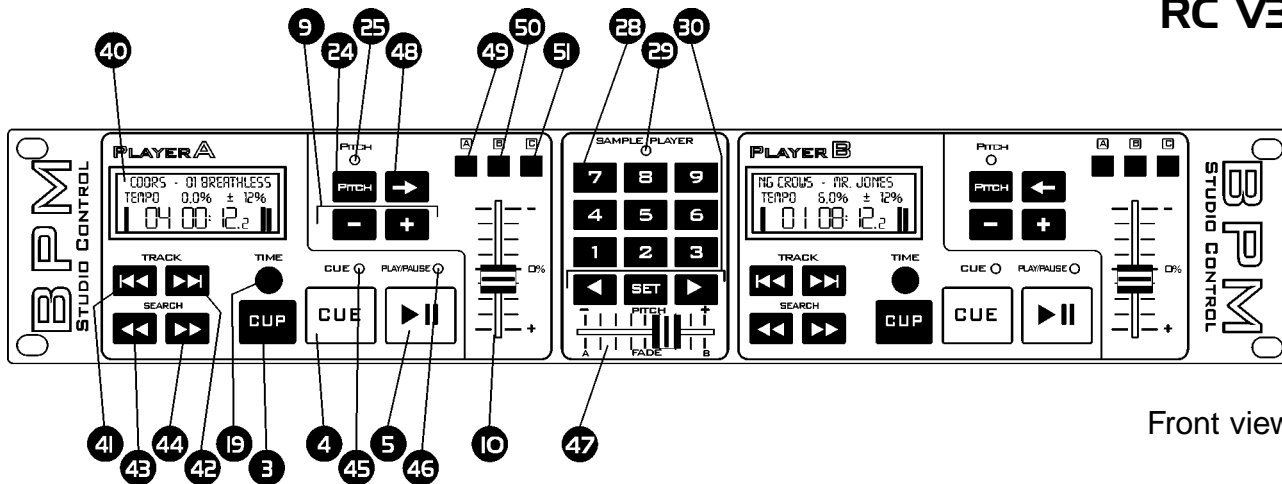

Front view



Reverse view



5. Remote Control Unit RC V3



The basic operation of the RC V3 is identical with the top area of the program window. If the remote control unit is registered in the **Program Options**, the program will check at start if the remote control unit is connected and ready.

Installation

(Also refer to the reminders for connection of remote control units, and reminders for the initial program start on page 13)

The remote control unit will be connected to the PC's serial port (COM1 or COM2) via its connection socket **[REMOTE/PC] [38]** and the supplied cable. A power supply unit is also provided.

Now start BPM Studio and open the remote control units register tab. The following adjustments need to be made:

COM1 / COM 2

Enter which COM port the unit is connected to.

RC Active

Mark this checkbox to inform the program about the presence of a remote control unit. The program will from now on check at start up if the unit is present, and ready.

Operation

The remote control unit is divided in sections for **Players A** and **B**, and the **Sample Player**. The basic functionality corresponds to the module descriptions on the according pages for **Player** and **Sample Player**.

If the program finds a external remote control unit at startup, and the controls of this unit are configured for **Pitch**, the pitch controls in the player's program window will be locked. Pitch modifications can then only be made at the remote control unit. The sliders on the monitor the merely indicate the slider position on the unit. The purpose of the sliders and the programmable multi purpose buttons can be assigned in the **Program Options**, register tab remote control unit. The two sliders on the two players **[10]** (Slider A and B in the Program Options) can either be used to control pitch, or volume. Thus, when using a notebook mixing can be done without external mixer, and the pitch will be adjusted by software. The slider in the **Sample Player [47]** (Slider C in the Program Options) can be programmed to control sample volume, sample pitch, or manual fading between player A and player B.



Also the multi purpose buttons in the top right corner of the two players **[49]**, **[50]** and **[51]** can be configured for different functions.



Controls at the front side of the device:

[3] Cue-Play-Button

This button combines the two buttons Cue and Play. If the player is in play mode (The green LED [46] is on) it will jump back to the previous Cue Point and start playing from there on, upon pressing the [Cue-Play] button. If the player is in pause mode, it will jump to the current Cue Point, and play from there on.

Alternative Cue-Play Function

Alternatively to the functions of the [Cue-Play] button described above, another variant can be selected in the Program Options. If this other variant is selected, the title will start playing upon pressing the [Cue-Play] and will play as long as the button is held. Upon releasing the button the title will be reset to the current Cue Point

[4] Cue Button

Upon pressing this button the player will jump back to the previous Cue Point, and switch to pause mode.

When pressing the button for longer than one second, the player will jump back to beginning of the title res. will jump back to that Cue Point when pressing for more than one second again.

[5] Play Button

When pressing this button the player will start playing from its current position, res. from the set Cue Point. If pressed again the player will go back to pause mode.

The current starting position of the player will be saved as Cue Point if the Play button is pressed again, and can be located with again at any time with the [Cue] button.

[9] Pitch-Bend-Button

With these keys the playback speed can temporarily be in- or decreased. An indispensable tool when synchronizing the beats of two titles

[10] Pitch Control

Adjust this control to the desired playback speed. On the display [40] the deviation will be indicated in %.

This control is only active when the [Pitch] – button [24] is switched on, and the Pitch-LED [25] is also on.

[19] Time Button

With this button the time indicator in the display [40] can be switched between elapsed, and remaining playtime.

[24] Pitch Button

This button can block adjustment of the playback speed with the [Pitch-Control] [10]. The Pitch LED [25] will indicate the current status.

[25] Pitch LED

This LED indicates if the Pitch Control [10] is active.



[28] Sample Buttons 1 to 9

These buttons start the samples 1 to 9 of the Sample Player of BPM Studio. Read the chapter **Sample Player** in this manual to learn about the different possibilities when working with samples.

[29] Sampler-Status-LED



The three colored status LED indicates the mode of the Sample Player. If green, the Sample Player is ready. Orange means ready in scratch mode. A red LED indicates that data is loaded into the Sampler. During this period no samples can be played.

[30] Sampler-Control, res. controlling the Preview Player

With the two buttons  and  the Sample Player's output can be assigned to **Player A** or **Player B**. This is only necessary if the Sample Player does not have its own sound card channel assigned, res. only two channels are available (depending on hard- and software outfit of your system) The [0] – button stops the playback of all samples.



Controlling the Preview-Player:

Whenever the Sample-Player is in pause-mode, meaning, when no sample is played, you can start the preview player from within the File Archive with the **[0]** button. Now the selected title will be played over the monitor channel and can be screened independently from the running program. In this mode the two  and  buttons function as rewind and fast forward.

[40] LCD Displays

In the LCD display the most important feedback of the particular player is indicated.

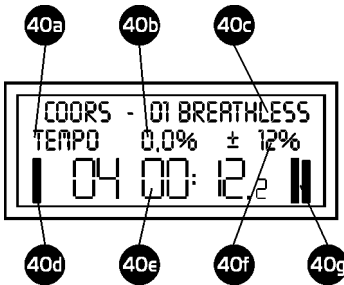

[40a] Indicates if speed control is applied with or without master speed function. (At this remote control unit only at the program window of the two players).

[40b] The deviation of the title from its standard speed in %

[40c] Current title. Here the title and artist are indicated out of the ID3 tag of this MP3 File. This display will scroll automatically if not all information of this tag can be displayed. If problems with the system's performance are at hand, this scrolling can be deactivated in the Program Options, on the register tab remote control unit.

[40d] Indicates the pre load buffer

[40e] Current playtime (Can be switched between ELAPSED and REMAIN with the **[TIME]** button **[19]**)

[40f] Indicates the selected pitch range. This selection can be made with the multi purpose buttons

A, B, and C (**[49]**, **[50]** and **[51]**) if this is set up accordingly in the Program Options. (see also page 11)

[40g] Signal level indicator

[41] to [44] Track- and Search buttons

With the track buttons you can select titles in currently loaded play list. The search buttons are used for exact setting of Cue Points. For this purpose a small portion of the title will be played as a loop. The position of this loop will then be moved with the search buttons.

Also read the chapter about players in this manual.

[45] Cue LED

This LED will come on if the player goes into pause mode

[46] Play LED

This LED will come on if the player goes into play mode

[47] Manual Fader res. Sampler Pitch

The horizontal control below the Sample Player can be used as manual fader, sample volume control, or pitch control of the sample player. The according settings are defined in the Program Options, on the remote control register tab.

When set as manual fader cross fades between player A and B can be created without external mixer.



[49], [50], [51] Universal keys

The universal keys can be verified in the program options, section Remote Control , every time as described below:

- The A [49] key:**
 - Pitch range 1
 - Player A Monitor
 - Loop - Sampler Record
- The B [50] key:**
 - Pitch range 2
 - Player B Monitor
 - Loop - Sampler play
- The C [51] key:**
 - Pitch range 2
 - CD Player Monitor
 - Loop - Sampler Play

[38] Serial cable socket (reverse side)

Connect plug (9-pin, Sub-D) of Remote Control Unit through serial cable to your PC. The maximal cable's length is 15 m, however we do not recommend to use more than 10 m.

[39] Power supply socket (reverse side)

Connect delivered power supply cable (9 V, at least 500 mA).

[52] Fader start cable socket (reverse side)

Connect to this plug (9-pin, Sub-D) an Fader start cable which is optional available as accessory by ALCATech. Please read instructions of 'Fader start' on the following pages of the manual before using it the first time.

Fader Start Functions RC V3 (BPM Studio Pro/HW from Ver. 3.00 B)

Fader start functions are only working with a Remote Control Unit from Ver. 3.00 B. According to the Remote Control Unit, connection of the mixer (fade start enabled) via the Fader-Start-Adapter (special accessory) or by the normal 3,6 mm stereo jack cable. Please pay attention to the installation instructions in the chapters of respective RCs, if you have acquired adapter separately or later.



From Ver. 3.00 B will be supported:
Mixer with Reedcontact or microsensor,
Mixer with of impulse control (for example PIONEER) is Ver. 3.00 C required.

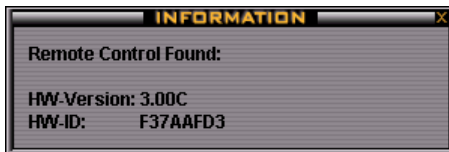

In the program options, you can choose the following different operation modes:

Fader Start (*Program options / Remote Control Unit*)

If this checkbox is active, then Player starts when the control of the external mixer will be put on.

Fader Stop (*Program options / Remote Control Unit*)

If this checkbox is active, then Player stops when the control of the external mixer will be put off.

The version number of your Remote Control Unit will be shown during start-up / Program start of BPM Studio. (By pressing CTRL key, the dialog box stays visible until the key will be released again).



Fader Start Functions RC V3 (BPM Studio Pro/HW from Ver. 3.00 B)

So you can connect Fader start adapter to Remote Control Unit and to the external Mixer

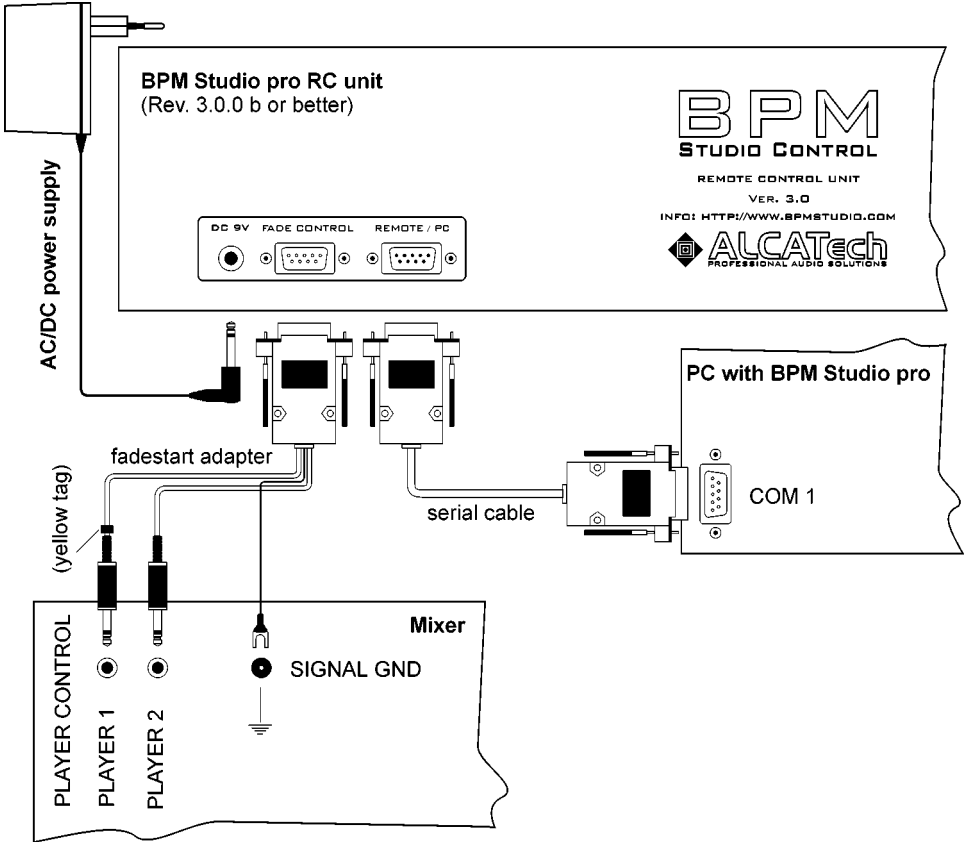

RCP-1001



BPM Studio

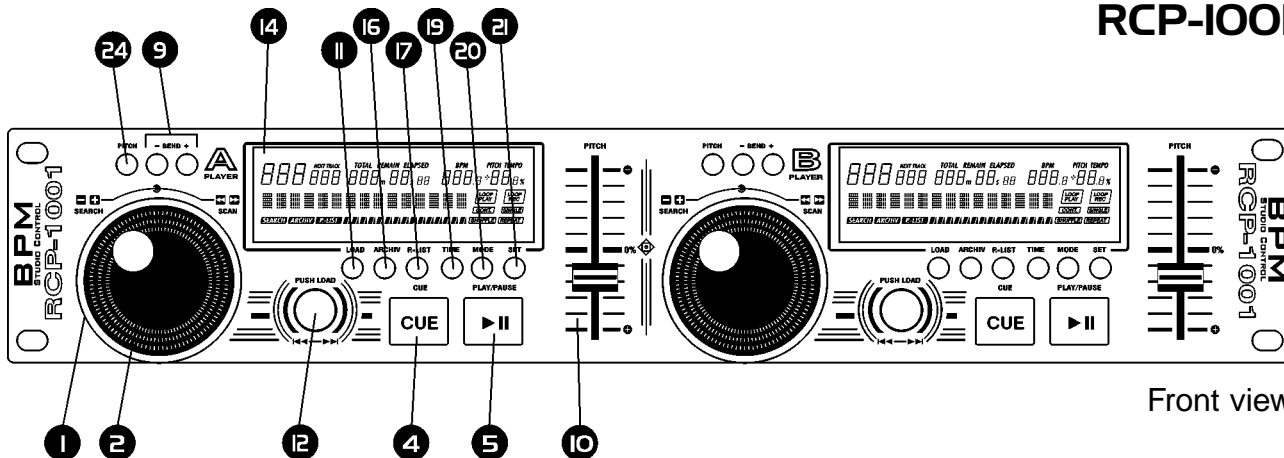

Front view



Reverse view

RCP-1001 view



6. Remote Control Unit RCP-1001



Remote Control Unit RCP-1001 is a simple version of the RCP-2001 with a limited functions range. It works with the BPM Studio Professional und with BPM Studio LE ex Version 4. Besides of very clear VFD displays, it is equipped , exactly as RCP-2001, with Track Selector and Jog Shuttle Wheels as well. It allows among other to choose directly the titles of the file archives (only BPM Studio Pro software). If external Remote Control Unit is logged-on in the **program options**, then program examines during start up, if the Remote Control Unit is connected and operative.

Installation

(Please, read the instructions on how to connect the Remote Control Unit on page 12 and instructions how to run the program for the very first time on page 13).

Connect **[REMOTE/PC] [38]** socket of Remote Control Unit using the supplied cable to a serial port (COM1 or COM2) on your computer. Power supply is given by delivered power adapter. Following settings should be made:

COM1 / COM 2

Select to which COM port the Remote Control Unit is connected

RC Active

Select this check box to inform the program that a Remote Control Unit is connected. Every time the program is started it will check, if Remote Control Unit is connected and operative.

Operation

The Remote Control Unit contains a controller for both **Player A** and **B**. The basic functionality is the same as described in the section of the manual dedicated to the player. When the program finds an external Remote Control Unit during its startup and the Remote Control Unit has the pitch button activated, then the pitch slider of both players in the program are locked. Only the external Remote Control Unit can change the pitch. The slider on the screen shows merely the position of the slider on the Remote Control Unit. Using the Remote Control options tab in the **program options**, you can program the slide bars. They are adjustable by either Pitch or volume. If you are using the notebook version, it is also possible to mix without an external mixer. The Pitch setup will be taken over by the software.



Control elements on the front side of device:

[1] [2] Jog Shuttle Wheel

The Jog Shuttle Wheel allows you to use a lot of the BPM Studio functions easily and ergonomically. The external ring [1] and the internal disc [2] are working touch sensitive. If the ring is moved further i.e. if the internal wheel is moved more quickly so the parameter modification of the player will be made more quickly. Jog Shuttle Wheel have 3 operation modes: Search, Cue und Archive mode.

Jog Shuttle Wheel in Search Mode:

This is the standard mode which is active during play of any title. Search Mode will be shown in the Display [14] by symbol **SEARCH**. You can influence the play back of the loaded or played title with the wheel.

You can move the loaded title forward or in the reverse direction using the external ring. According to the turn angle of the ring [1], there are 3 different search speeds available (+1, +2, +3 or -1, -2, -3) and step mode where you can play the title in 1 minute steps (+min or -min).

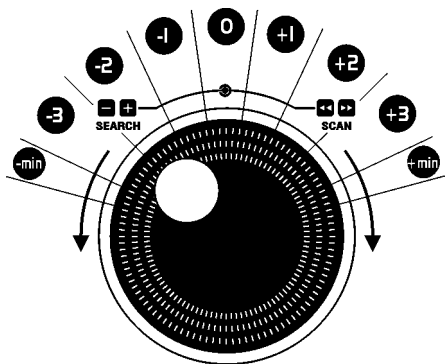

Using the internal disc [2] of the Jog Shuttle Wheel this title will slow down or accelerate. It works also when title slows down straight by BRAKE function or on start-up.

Jog Shutter Wheel in Cue Mode:

If the Player is in Pause Mode, then a Cue Point can be set exactly with the internal disc [2]. If the Player is stopped and the disc will be moved by one step, then the Player goes into this mode and 160 ms of the current play position will be played repeatedly as Loop. This position can be now positioned exactly before the next Beat. Changes of the Cue-Point are taken over by pressing the Cue key anew.

Beat-Stepping:

If in the Cue mode the [LOAD] key [11] is additionally held down, then you can move exactly step-by-step forward or backwards to a Beat in the title. Read chapter "Beat Stepping using the BPM Studio" too.

Jog Shuttle Wheel in Archive Mode:

In the Archive mode you can comfortably navigate in File Archive or Playlist Archive using this wheel. You can switch into the appropriate mode using [Archive] or [P.List] keys [16], [17]. The archive mode is shown in the display by the symbols **ARCHIV** or **P-LIST**. Choose the desired group in left part of archive window using external ring [1]. Once more you can choose from four different Scroll speeds. -1 or 1 switches exactly one group further or back. +2/+ 3 or -2/-3 present two different search speeds in the list with the groups. +min/-min finally moves the selction bar to the beginning or to the end of the list.

A group will be opened if you stay longer than one second on a group using the selection bar. Then, you can select the subgroups using the Jog Wheel. Now in this case you can load the complete group into Playlist by pressing the [LOAD]-key [11].

You can also select any title from the group using internal disc [2]. Loading may be made also by [LOAD]-key [11]. By a simple click, the title will be loaded into Playlist after the marked position.



If you would like to play the title immediately, then load it directly to the Player by double click. The just selected group or title will be shown in the display [14] during the selection using the Jog Shuttle Wheel. Therefore the Archive can be operated without looking constantly at the monitor. You can move back to the Search mode by pressing the **[ARCHIVES]** or **[P.List]** key [16, 17] anew. The Archive mode ends automatically after 10 seconds without any entry.

[4] Cue Button

Pressing this key moves the player back to the last Cue-Point and goes into Cue mode. Press the Cue key longer than one second and the player then moves to the beginning of the title or by pressing one second again will move it to the current Cue-Point.

[5] Play Button

Pressing this key starts the player from the current position (i.e. the Cue-Point). If the Play button is pressed again, the player goes into Pause Mode. The current start position of the player (before any anew pressing on the Play key is made) is stored as a Cue-Point and can be started again with the **[Cue]** key any time.

[9] Pitch-Bend Buttons

Using these keys, you can temporarily increase or decrease the play speed. These keys are an indispensable tool for synchronizing the second title's Beats. They are used to navigate by Beat in a title, if the Player is in Cue Mode (see also chapter 'Beat stepping using BPM Studio').

[10] Pitch Slider

Set the desired playback speed using the Pitch Slider. The actual speed in BPM appears on the display [14] as well as the difference in percent. The slider is only active if the **[Pitch]** key [24] is on and the Pitch-LED [25] enlightens.

[11] LOAD Button

The function of this key depends on the set mode of the Jog Shuttle Wheel [1] and [2]. In Search mode (standard), the next title of the Playlist is loaded into the Player by pressing of the **[LOAD]** key.

In Cue mode, additional holding of **[LOAD]** key will cause a change of current position of Cue-Point by beat or by tact (see chapter 'Beat stepping using BPM Studio' too). In Archive mode, pressing the **[LOAD]** key will load the selected title into the Playlist using the Jog Shuttle Wheel. This title will be loaded into Player immediately by double click.

Holding the key longer than 3 seconds will replace the complete Playlist by the selected group or playlist in the archive.

[12] Track Selector

You can move inside the Playlist using the Track Selector. A full turn of the ring switches 24 titles down the list. If you navigate in really big lists, then by pressing the Track Selector and turning it at the same time, you can move by 10 steps at a time. By pressing the button the selected title will be loaded into the Player.

[14] The VFD display

In the VFD display, all the parameters and activity modes of the respective Player will be shown as follows:

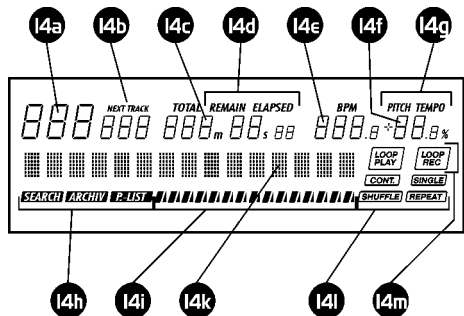



[14a] Indicates the number of loaded Tracks

[14b] NEXT TRACK indicator.
(Not active by RCP-1001)

[14c] Displays the time. Playtime of the title is shown in minutes, seconds and in tenth of seconds. Time information can be switched over by using the **[TIME] key [19]** between total title play time (ELAPSED), remaining title play time (REMAIN) and total remaining play time of the playlist (TOTAL). If the Player is in Cue mode, then the current Cue-Point will be shown.

[14d] Operation mode of the time display, switchable by the **[TIME] key [19]**

[14e] BPM value indicator, here the display will show BPM value taken from the ID3-Tag of the loaded title or value of real time BPM Counter.

[14f] Displays Pitch value in percents.

[14g] Displays the Pitch mode type. According to the chosen mode in the program panel, you will see if the changes of speed will work with or without change of the sound level (Master-Tempo).

[14h] Displays the mode of Jog Wheel. Using the Archive **[16]**, **[17]** keys it is possible to switch between operation modes of the Jog Wheels.

ARCHIV indicates File Archive Mode, **P-LIST** indicates the Playlist Archive Mode and the **SEARCH** Search Mode (standard operation mode).

[14i] Bar indicator displays the current play position

[14k] The title display shows the current loaded title and the interpreter from ID3- Tag of the MP3 file. The display scrolls automatically when data cannot be completely presented. If you experience problems with the performance of your system, title scrolling can also be turned off in the program options of the Remote Control Unit.

This display can be also used to show a lot of supplementary information. In the archive mode for example, the respective selected group, Playlist or the title in archive will be displayed here temporarily.

[14j] Displays the four additional functions: Single-/Continous-Play, Shuffle and Repeat. Programming can be done using the **[MODE] key [20]** and **[SET] key [21]**.

[14 m] Display for the Loop-Sampler
(not active in BPM Studio LE or RCP-1001)

[16], [17] Archive Keys

Using the **[ARCHIVE] [16]** key you can switch the Jog Wheel [1], [2] into the File Archive Mode. It is indicated additionally in the display by symbol. The **[P.List] key [17]** switches to the Playlist Archive mode. By pressing the key again the Search mode will be switched back (switching back takes place automatically as well, when any other key of the Player is pressed or after 30 seconds, if you have not moved the Jog Shuttle Wheel during this time).

[19] Time Button

Using this button you can switch the play time indicator in display **[14]** between total play time (ELAPSED) and remaining time of title (REMAIN). (TOTAL is not supported at present)

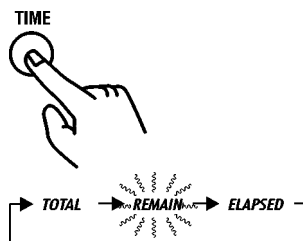

[20] MODE Button

By this button you can program four additional functions: Single-/Continous-Play, Shuffle and Repeat.

By pressing this **[MODE] button** multiply you can select one of the modes. Corresponding indicator will blink in display **[14]**.

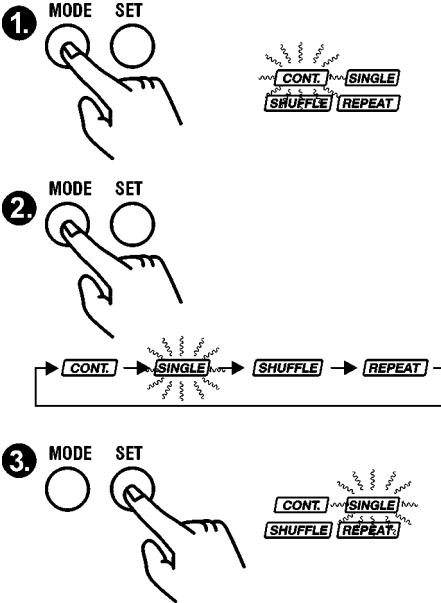

[21] SET Button

(Also BPM Match key) The current BPM value of respective (Master) Player will be taken over by pressing the SET key in Standard Mode. Read also chapter 'Beat-Matching using BPM Studio'. Please read in this chapter the exact description of the function of the SET button. If the Programming Mode is active (**[MODE]-key [19]** pressed), pressing the SET key will then switch that function on or off.

[24] Pitch Button

Using this key, you can deactivate the settings of the playback speed via the **[Pitch slider] [10]**.

Now, using the **[SET]-key [21]** function, you can switch it on/off.

Continuous Play [CONT.]:

If this mode is activated, then next title in the Playlist will be automatically loaded and played at the end of the current title.

Single Play [SINGLE]:

If this mode is activated, then next title in the Playlist will be automatically loaded but not started at the end of the current title.

Shuffle [SHUFFLE]:

The titles in the Playlist will be played in random order. Each change of the Playlist will cause a random new title order of list as long as this mode is enabled.

Repeat [REPEAT]:

If this function is active, then the loaded title is played continuously. If this function is turned off, then the next title of the list will be loaded.

Reverse side sockets:

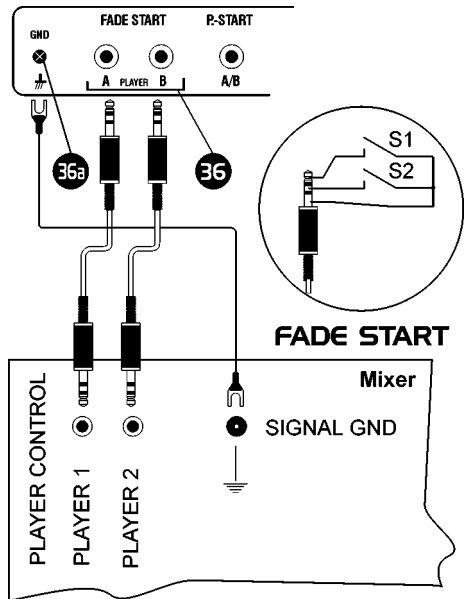



[36] Fade Start Input Socket

This socket usually works with all mixers that have an available fade/start function, for example the PIONEER series. Connect the plug (1/8 inch jack) of the Remote Control Unit using a universal cable to your mixer. Connect the ground device (**GND [36a]**) with the ground of the mixer.

How it works:

Both players are controlled by a separated 1/8 inch stereo jack. The player starts by locking the contact S1 (temporarily or constantly) and stops when contact S2 is locked (temporarily or constantly). Through program options you can activate fade start and also stop the separate fade. Do not set up the grip ground to the same as the device ground! This will avoid a short circuit between the device and the grip ground.

[36a] Device ground

Connect the device ground (GND) to the ground of mixer.

[37] Remote start input (P. START)

This input works with mixers through the Remote Start function (or Puls Start). An example would be some of the BEHRINGER models. Both players will be controlled using one contact. Connections to the mixer are mostly accomplished through a 1/4 inch - mono jack. Connection to the BPM Studio Remote Control Unit RCP-1001 by the RCP-2001 can be made through a 1/8-inch stereo jack. So, please use an adapter connecting the 1/8-inch stereo jack to 1/4 inch - mono jack. Remote Start Input has to be chosen in the program options (index card „Remote Control“, Checkbox „Puls Start“). Finally you can activate Fader-Start and Fader-Stop.

How it works:

Player A is started by locking contact A and is stopped by locking it once more. The same is valid for Player B and contact B. Through program options you can activate fade start and also stop separate fade.

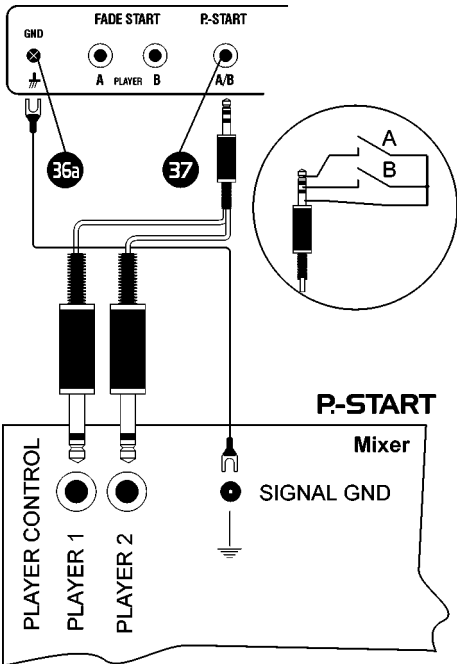

[38] Serial cable socket

Connect the (9-pin, Sub-D) plug of the Remote Control Unit with the supplied serial cable to your PC. The maximum length of cable that can be used is 49.2 feet (15 m), however we do not recommend using more than 32.8 feet (10 m). Another socket to connect power supply and serial connection is on the left side of casing. This makes it possible to use Remote Control Unit also as table device without bothering plugs on the back side of device. To use it you need a special cable, which is available from your local ALCATech dealer or directly from ALCATech.

[39] Power supply socket

Connect delivered power supply cable (12 V, at least 1 A) to this socket.



RCP-2001-B

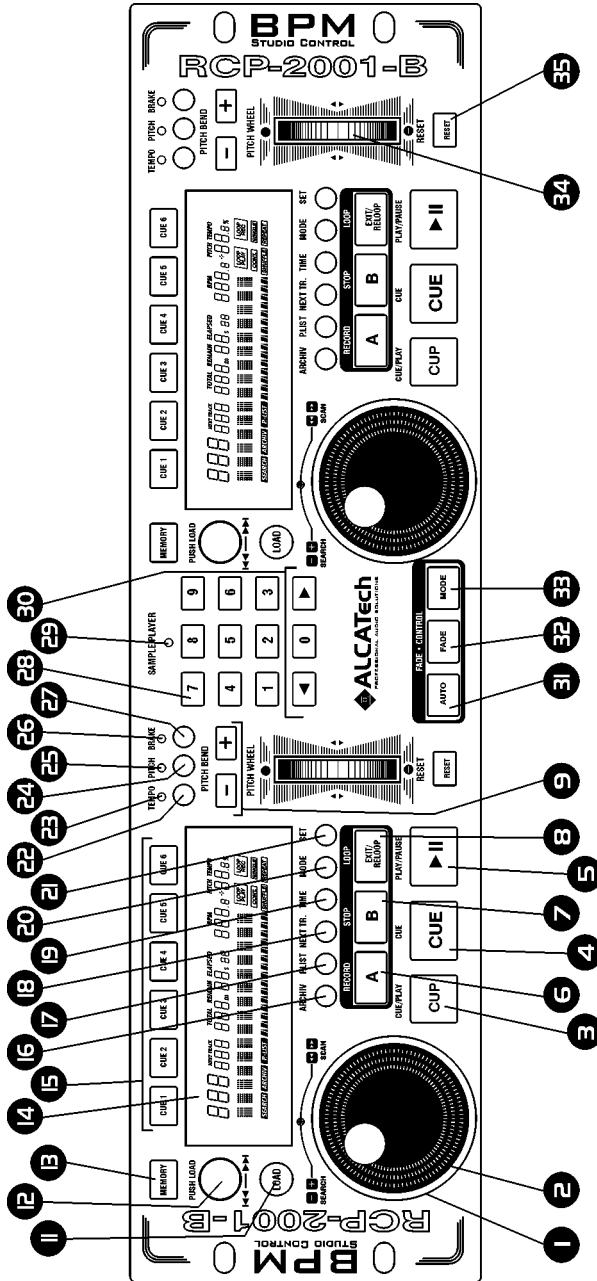

Front view



RCP-2001-B



Reverse view



7. Remote Control Unit RCP-2001



RCP-2001-B with Pitch Wheel

The Remote Control Unit RCP-2001 is available in two different designs. The RCP-2000-A is equipped with a conventional Pitch-Slider. The RCP-2001-B is equipped with **Pitch-Wheels** developed by ALCATech. These Pitch-Wheels enable independent changes of Pitch value of both Players between Software and Remote Control Unit. It is especially of importance by using the BPM Match function or by connecting several Remote Control Units. Not lastly it is also possibility to make finer regulation of Pitch values up to 0.1 % steps. The RCP-2001 works with BPM Studio LE and Professional from Version 4 up. In addition to the easily readable VFD display, it is equipped with Direct-Cue keys, Loop - Sampler and Jog Shuttle Wheels. Among others, it allows direct selection of titles from the File archives (only in BPM Studio Pro software).

Installation

(Also, read the instructions on how to connect the Remote Control Unit on page 12 and instructions how to run the program for the very first time on page 13).

Connect **[REMOTE/PC] [38]** socket of Remote Control Unit using the supplied cable to a serial port (COM1 or COM2) on your computer. Power supply is given by delivered power adapter. All settings will be made by index card Remote Control and are in chapter 3.18 'Program options' detailedly described.



*RCP-2001-A
with Pitch Slidern*

Operation

The Remote Control Unit controls both **Players** A and B. The essential function of the unit corresponds to the description of the player on the corresponding pages of that manual. If the program finds an external Remote Control Unit and the sliders of the Remote Control Unit are configured at Pitch during start up, then the Pitch sliders of both players are set in the program panel interface. Then Pitch modifications can be made but only using the external Remote Control Unit. The Sliders on the screen will only show the position of the sliders.

Using the Remote Control options tab in the **program options**, you can program the slide bars of the RCP-2001-A. They are adjustable by either Pitch or volume. If you are using the notebook version, it is possible to mix with the RCP-2001-A without using an external mixer. The pitch setup will be taken over by the software.



Control elements on the front side of device:

[1] [2] Jog Shuttle Wheel

The Jog Shuttle Wheel allows you to use a lot of the BPM Studio functions easily and ergonomically. The external ring [1] and the internal disc [2] are working touch sensitive. If the ring is moved further i.e. if the internal wheel is moved more quickly so the parameter modification of the player will be made more quickly. Jog Shuttle Wheel have 3 operation modes: Search, Cue und Archive mode.

Jog Shuttle Wheel in Search Mode:

This is the standard mode which is active during play of any title. Search Mode will be shown in the Display [14] by symbol **SEARCH**. You can influence the play back of the loaded or played title with the wheel.

You can move the loaded title forward or in the reverse direction using the external ring. According to the turn angle of the ring [1], there are 3 different search speeds available (+1, +2, +3 or -1, -2, -3) and step mode where you can play the title in 1 minute steps (+min or -min).

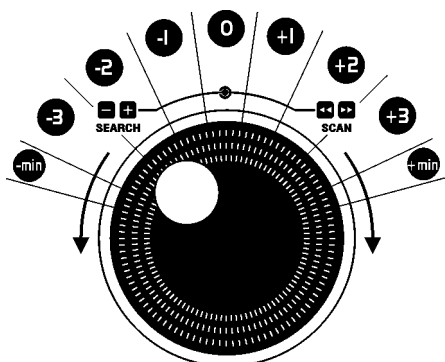

Using the internal disc [2] of the Jog Shuttle Wheel this title will slow down or accelerate. It works also when title slows down straight by BRAKE function or on start-up.

Jog Shutter Wheel in Cue Mode:

If the Player is in Pause Mode, then a Cue Point can be set exactly with the internal disc [2]. If the Player is stopped and the disc will be moved by one step, then the Player goes into this mode and 160 ms of the current play position will be played repeatedly as Loop. This position can be now positioned exactly before the next Beat. Changes of the Cue-Point are taken over by pressing the Cue key anew.

Beat-Stepping:

If in the Cue mode the [LOAD] key [11] is additionally held down, then you can move exactly step-by-step forward or backwards to a Beat in the title. Read chapter "Beat Stepping using the BPM Studio" too.

Jog Shuttle Wheel in Archive Mode:

In the Archive mode you can comfortably navigate in File Archive or Playlist Archive using this wheel. You can switch into the appropriate mode using [Archive] or [P.List] keys [16], [17]. The archive mode is shown in the display by the symbols **ARCHIV** or **P-LIST**. Choose the desired group in left part of archive window using external ring [1]. Once more you can choose from four different Scroll speeds. -1 or 1 switches exactly one group further or back. +2/+ 3 or -2/-3 present two different search speeds in the list with the groups. +min/-min finally moves the selction bar to the beginning or to the end of the list.

A group will be opened if you stay longer than one second on a group using the selection bar. Then, you can select the subgroups using the Jog Wheel. Now in this case you can load the complete group into Playlist by pressing the [LOAD]-key [11].

You can also select any title from the group using internal disc [2]. Loading may be made also by [LOAD]-key [11]. By a simple click, the title will be loaded into Playlist after the marked position.



If you would like to play the title immediately, then load it directly to the Player by double click. The just selected group or title will be shown in the display [14] during the selection using the Jog Shuttle Wheel. Therefore the Archive can be operated without looking constantly at the monitor. You can move back to the Search mode by pressing the **[ARCHIVES]** or **[P.List] key [16, 17]** anew. The Archive mode ends automatically after 10 seconds without any entry.

[3] Cue-Play button

This key unites two keys: Cue and Play. If the player is in Play Mode (green LED [46] lights), then the player moves back to the last Cue-Point by pressing the the **[Cue-Play]** button and begins to play again from there. If the player is in Cue Mode, then the title will be started from the current Cue-Point.

Alternative Cue-Play function

As alternative to the described function of the **[Cue-Play] key**, second variant can be chosen from the program options. The title starts then by pressing the **[Cue-Play] key** and goes until the key is released and then it moves back to the current Cue-Point.

[4] Cue Button

Pressing this key moves the player back to the last Cue-Point and goes into Cue mode. Press the Cue key longer than one second and the player then moves to the beginning of the title or by pressing one second again will move it to the current Cue-Point.

[5] Play Button

Pressing this key starts the player from the current position (i.e. the Cue-Point). If the Play button is pressed again, the player goes into Pause Mode. The current start position of the player (before any anew pressing on the Play key is made) is stored as a Cue-Point and can be started again with the **[Cue] key** any time.

[6], [7], [8] Loop Player

Using Loop Player you can repeat any programmed sequence as often as you wish. You can set start and end points on-the-fly. Each Loop can also be stored in Direct Cue key [15] and is also at the disposal again after system restart. You will find exact description how it works in chapter 'First steps - Working with Loop Player'.

[9] Pitch-Bend Buttons

Using these keys, you can temporarily increase or decrease the play speed. These keys are an indispensable tool for synchronizing the second title's Beats. They are used to navigate by Beat in a title, if the Player is in Cue Mode (see also chapter 'Beat stepping using BPM Studio').

[10] Pitch Slider

Set the desired playback speed using the Pitch Slider. The actual speed in BPM appears on the display

[14] as well as the difference in percent. The slider is only active if the **[Pitch] key [24]** is on and the Pitch-LED **[25]** enlights.

[11] LOAD Button

The function of this key depends on the set mode of the Jog Shuttle Wheel **[1]** and **[2]**. In Search mode (standard), the next title of the Playlist is loaded into0 the Player by pressing of the [LOAD] button. In Cue mode, additional holding of LOAD button will cause a change of current position of Cue-Point by beat or by tact (see chapter 'Beat stepping using BPM Studio' too). In Archive mode, pressing the LOAD button will load the selected title into the Playlist using the Jog Shuttle Wheel. This title will be loaded into Player immediately by double click. Holding the key longer than 3 seconds will replace the complete Playlist by the selected group or playlist in the archive.



[12] Track Selector

You can move inside the playlist using the Track Selector. A full turn of the ring causes switching 24 titles down the list. If you navigate in really big lists, then by pressing the Track Selector and turning it at the same time, you can move by 10 steps at a time. By pressing the button chosen title will be loaded into player.

[13] MEMORY button

(not active in the BPM Studio LE)

This key has vast functions to store and delete different Cue-Points, Loop and other parameters. Pressing this button switches the Player into memory mode. It will be indicated while the key lights in green. The memory mode will be abandoned automatically after 10 seconds without any entry.

1.) If the Player is in the Play mode, then pressing **[MEMORY]** button, followed by **DirectCue key [15]** will set Cue-Point "on-the-fly".

2.) If the Player is in the Pause mode, then pressing **[MEMORY]** button, followed by **DirectCue key [15]** will store current play position as Cue-Point on this DirectCue key.

3.) If the Player is in the Loop Player mode, then pressing **[MEMORY]** button, followed by **DirectCue key [15]** will store current Loop on DirectCue key.

4.) If the Player is in the Loop Player mode, then pressing **[MEMORY]** button, followed by Sample Player key will store current Loop on this Sample Player key [28].

5.) Pressing on **[MEMORY]** button, followed by **[SET]-key [21]** will take over BPM value discovered by real time BPM-Counter into ID3-Tag.

6.) Holding on **[MEMORY]** button and simultaneously pressing DirectCue key will delete Cue-Point or Loop of this key.

7.) Holding on **[MEMORY]** button and simultaneously pressing key A of the Loop Player **[6]** will delete stored Loop.

8.) Pressing on **[MEMORY]** button longer than 3 seconds will complete DirectCue keys and Loop Player deleted.

You will find detailed description of these functions in chapters "Working with DirectCue keys" and "Working with Loop Player" of manual worker.

[14] The VFD display

In the VFD display, all the parameters and activity modes of the respective Player will be shown as follows:

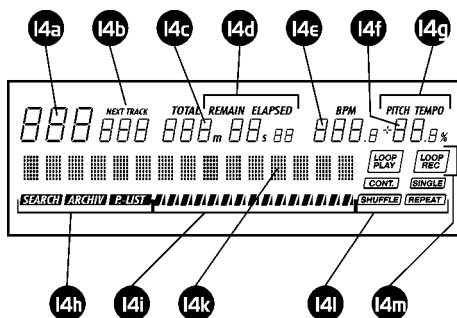

[14a] Indicates the number of loaded Tracks

[14b] NEXT TRACK indicator. *(Not active by RCP-1001)* Indicates the Titel "parked" by the **[NEXT TRACK]-button [18]**

[14c] Displays the time. Playtime of the title is shown in minutes, seconds and in tenth of seconds. Time information can be switched over by using the **[TIME]** key **[19]** between total title play time (ELAPSED), remaining title play time (REMAIN) and total remaining play time of the playlist (TOTAL). If the Player is in Cue mode, then the current Cue-Point will be shown.

[14d] Operation mode of the time display, switchable by the **[TIME]-key [19]**



[14e] BPM value indicator, here the display will show BPM value taken from the ID3-Tag of the loaded title or value of real time BPM Counter.

[14f] Displays Pitch value in percents.

[14g] Displays the Pitch mode type. According to the chosen mode in the program panel, you will see if the changes of speed will work with or without change of the sound level (Master-Tempo).

[14h] Displays the mode of Jog Wheel. Using the Archive **[16]**, **[17]** keys it is possible to switch between operation modes of the Jog Wheels. [Archive] indicates File Archive Mode, [P.List] indicates the Playlist Archive Mode and the [Search] Search Mode (standard operation mode).

[14i] Bar indicator displays the current play position

[14k] The title display shows the current loaded title and the interpreter from ID3- Tag of the MP3 file. The display scrolls automatically when data cannot be completely presented.

If you experience problems with the performance of your system, title scrolling can also be turned off in the program options of the Remote Control Unit.

This display can be also used to show a lot of supplementary information. In the archive mode for example, the respective selected group, Playlist or the title in archive will be displayed here temporary.

[14l] Displays the four additional functions: Single-/Continuous-Play, Shuffle and Repeat. Programming can be done using the **[MODE]** key **[20]** and **[SET]** key **[21]**.

[14m] Display for the Loop-Sampler
(not active in *BPM Studio LE* or *RCP-1001*)

[15] DirectCue keys 1 - 6

(Not active in the BPM Studio LE)

The Direct-Cue keys make it possible to store up to 6 favourite positions in any title as Cue-Point on-the-fly or optionally to save Loops recorded with the Loop Player. Then, these points and Loops can be started just by a single touch of the DirectCue key. Stored Cue-Point will be indicated by a key lightning in red. If a stored Loop is on this key, then key color is changed into orange. Read all about these keys in chapter "Working with DirectCue keys" and "Working with the Loop Player".

[16], [17] Archive button

Using the **[ARCHIVE]-key [16]** you can switch the Jog Wheel **[1]**, **[2]** into the File Archive Mode. It is indicated additionally in the display by **ARCHIV** symbol. The **[P.List] key [17]** switches to the Playlist Archive mode **P-LIST**. By pressing the key again the Search mode will be switched back **SEARCH** (switching back takes place automatically as well, when any other key of the Player is pressed or after 30 seconds, if you have not moved the Jog Shuttle Wheel during this time).

[18] NEXT TRACK button

Using this function, you can "park" any next title in waiting position during current reproduction of a title. Then, it will be played automatically as next title irrespective of current Playlist. Press NEXT TRACK key. In the display **[14]** will be **NEXT TRACK** displayed. Now, choose a title from current Playlist by the TRACK SELECTOR **[12]**. (Chosen title is shown in the display under **NEXT TRACK**). Optionnaly you can enlighten a title immediately and then start NEXT TRACK also by pressing TRACK-Selector.



[19] Time Button

Using this button you can switch the play time indicator in display [14] between total play time (ELAPSED) and remaining time of title (REMAIN). (TOTAL is not supported at present)

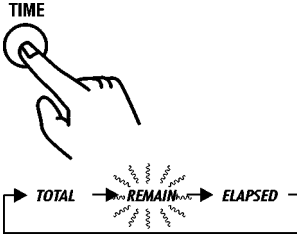

[20] MODE Button

By this button you can program four additional functions: Single-/Continuous-Play, Shuffle and Repeat.

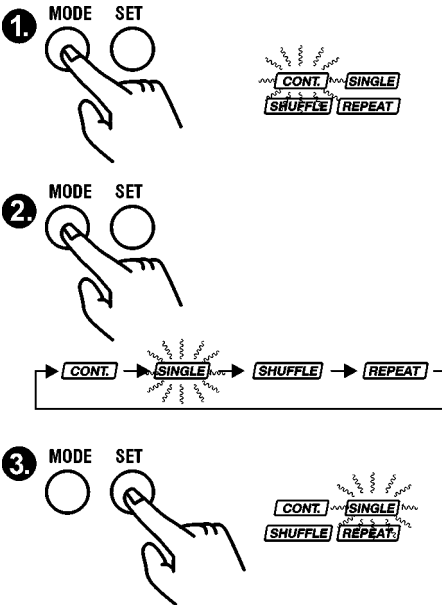

By pressing this **[MODE]button** multiply you can select one of the modes. Corresponding indicator will blink in display [14]. Now, using the **[SET]-key [21]** function, you can switch it on/off.

Continuous Play **[CONT.]**:

If this mode is activated, then next title in the Playlist will be automatically loaded and played at the end of the current title.

Single Play **[SINGLE]**:

If this mode is activated, then next title in the Playlist will be automatically loaded but not started at the end of the current title.

Shuffle **[SHUFFLE]**:

The titles in the Playlist will be played in random order. Each change of the Playlist will cause a random new title order of list as long as this mode is enabled.

Repeat **[REPEAT]**:

If this function is active, then the loaded title is played continuously. If this function is turned off, then the next title of the list will be loaded.

[21] SET Button

(Also BPM Match key) The current BPM value of respective (Master) Player will be taken over by pressing the SET key in Standard Mode. Read also chapter 'Beat-Matching using BPM Studio'. Please read in this chapter the exact description of the function of the SET button. If the Programming Mode is active (**[MODE]-key [19]** pressed), pressing the SET key will then switch that function on or off.



[22] Tempo Button

Press this key to change the playback speed without modification of the pitch. The TEMPO - LED [23] indicates the Master-Tempo function. Attention! The pitch range changes when closing the Master Tempo function. Please also read the information contained in chapter [Player](#) of this manual.

[23] TEMPO - LED

Is lit if the Master Tempo function is active.

[24] Pitch Button

Using this key, you can deactivate the settings of the playback speed via the [\[Pitch slider\]](#) [10].

[25] Pitch-LED

Is lit if the Pitch or Master Tempo function is active.

[26] BRAKE-LED

Is lit if the function BRAKE is active. If BRAKE is in progress, then this LED is blinking.

[27] BRAKE Button

The BRAKE function simulates braking down to 0 or the push of a turn-table. The effect is triggered if the BRAKE light is on and the title is started or stopped using the [\[PLAY\]](#) button [5]. Once the braking effect of the title has started you can slow it down or stop playing by using the internal Jog Wheel disc.



[28] Sample Player [1] to [9]

Using these keys you can start the Samples to 9 of the BPM Studio Sample Player. Read section [Sample Player](#) in this manual about different possibilities of working with samples.



[29] Sampler-Status-LED

3 colors LED display shows the Sample Player status. If the green light is on, then Sample Player is ready to work. Orange light indicates that Scratch mode is ready. Red light indicates that a file is loading into the Sampler Player. During this time no sample can be played.

[30] Sampler Control and Preview Player's Control

With both  and  keys you can assign output of the Sample Player to Player A or Player B. It is only necessary when no own sound card channel is assigned or only two output channels are at disposal (according to the hardware and software configuration of your system). [\[0\]](#) key stops playing all samples.

Preview Player's Control:

If the Sample Player is in Pause mode, that means, if no sample is played, you can start the Preview Player of the File archive using the [\[0\]](#) key. Now, the selected title will be played via the monitor channel and can be heard irrespectively of the running program. In this mode, the  and  keys work as fast forward and fast reverse.

[31], [32], [33] Fade Control

(not active in the BPM Studio LE)

These three keys adjust the automatic Cross fader.

[\[AUTO\]](#) [31] switches Auto-fade mode on or off. If the Auto-fade mode is activated then this key shines in red.

By the [\[FADE\]](#) key [32] you apply the set fade process to the current title. This key blinks in red as long as Cross fader is on and both Players run. Using the [\[MODE\]](#) key [33] you can switch between 6 different fade process presets. The current running fade process will be deleted.



[34] Pitch Wheel

(only in RCP-2001-B)

Set the desired playback speed using the Pitch Wheel. On the display [14] the actual speed in BPM and the difference in percent appear. The Wheel is only active if the [Pitch] key [24] is on and the Pitch-LED [25] is shining.

[35] Pitch Reset

(only in RCP-2001-B)

You can put the Pitch to 0 using this key.

Reverse Side Sockets:

[36] Fade Start Input Socket

This socket usually works with all mixers that have an available fade/start function, for example the PIONEER series. Connect the plug (1/8 inch jack) of the Remote Control Unit using a universal cable to your mixer. Connect the ground device (GND [36a]) with the ground of the mixer.

How it works:

Both players are controlled by a separated 1/8 inch stereo jack. The player starts by locking the contact S1 (temporarily or constantly) and stops when contact S2 is locked (temporarily or constantly). Through program options you can activate fade start and also stop the separate fade. Do not set up the grip ground to the same as the device ground! This will avoid a short circuit between the device and the grip ground.

[36a] Device ground

Connect the device ground (GND) to the ground of mixer.

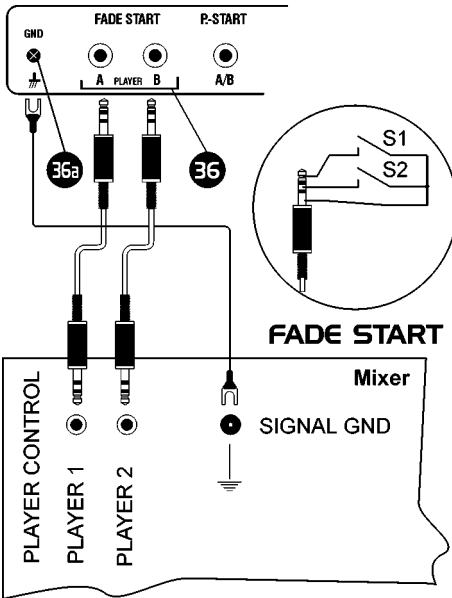



[37] Remote start input (P. START)

This input works with mixers through the Remote Start function (or Puls Start). An example would be some of the BEHRINGER models. Both players will be controlled using one contact. Connections to the mixer are mostly accomplished through a ¼ inch - mono jack. Connection to the BPM Studio Remote Control Unit RCP-1001 by the RCP-2001 can be made through a 1/8-inch stereo jack. So, please use an adapter connecting the 1/8-inch stereo jack to ¼ inch - mono jack. Remote Start Input has to be chosen in the program options (index card „Remote Control“, Checkbox „Puls Start“). Finally you can activate Fader-Start and Fader-Stop.

How it works:

Player A is started by locking contact A and is stopped by locking it once more. The same is valid for Player B and contact B. Through program options you can activate fade start and also stop separate fade.

[38] Serial cable socket

Connect the (9-pin, Sub-D) plug of the Remote Control Unit with the supplied serial cable to your PC. The maximum length of cable that can be used is 49.2 feet (15 m), however we do not recommend using more than 32.8 feet (10 m). Another socket to connect power supply and serial connection is on the left side of casing. This makes it possible to use Remote Control Unit also as table device without bothering plugs on the back side of device. To use it you need a special cable, which is available from your local ALCATech dealer or directly from ALCATech.

[39] Power supply socket

Connect delivered power supply cable (12 V, at least 1 A) to this socket.

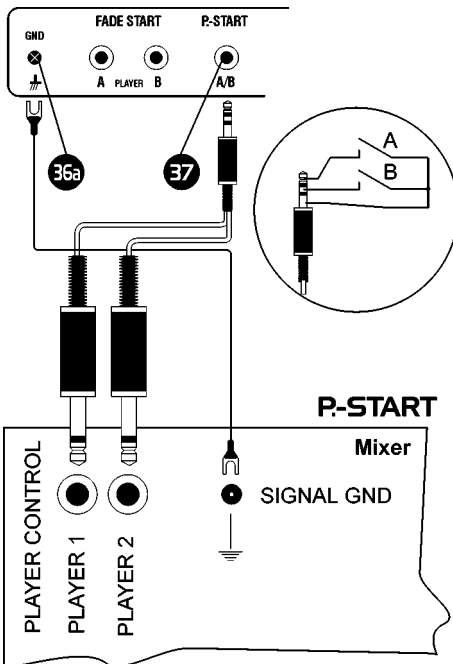



8.I. Working with Loop Player (only Remote Control RCP-2001)

Using the Loop Player you can repeat any programmed sequence as often as you wish. Start and exit points can be set on-the-fly and edited any time later. Using the Tact-Stepping function you can make each Loop wider or shorter in exact steps of 4 Beats. Each Loop can be also stored by the DirectCue key [15] or Sample Player key [28] and will be also at the disposal again after system restart.

Press the [RECORD] key [6] to set the start point of the sample (Point A) and to begin recording of the sample. [LOOP REC] will be shown in display and the A key shines.

8.1.1. Recording and reproduction of the Loop:

Learn in this section how you can record a sequence of the running title as Loop. The Player has to be in reproduction mode. To make first attempts, we recommend to use any title with well recognizable Beat (Dance, House or Techno-Track). It would be best if you try to press keys A and B in the exact tact.

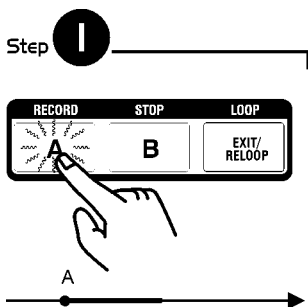
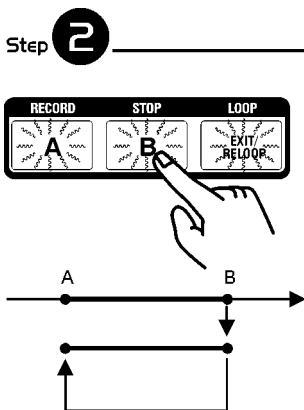

Press (for example after exactly 4 beats or 1 tact) the [STOP] key [7] to set the stop point of the sample (Point B). Now, the Player goes immediately into the Loop Mode and the stored tact will be repeated constantly. [LOOP PLAY] is shown in the display and the keys A and B are lighting in orange, the [EXIT/RELOOP] key will light in green. Simultaneously LOOP A <-> B will be shown in the title display.



As long as you pressed only the A key, you can overwrite the old start point of the Loop by pressing the A key anew and you set new point on-the-fly.



As soon as the B key is pressed, you can set the end point (B) on-the-fly by pressing the B key and again and reduce the Loop in this way.



Step **3**

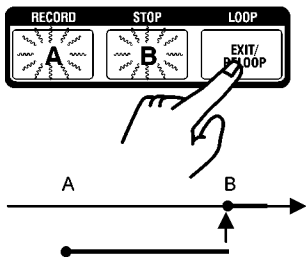

If you press the [EXIT/RELOOP] key, the sample will be played up to the point B and then pass seamless into the title again. In this time the [EXIT/RELOOP] key and [LOOP] are blinking. Finally all the three keys (A, B and [EXIT/RELOOP]) are lighting in orange.

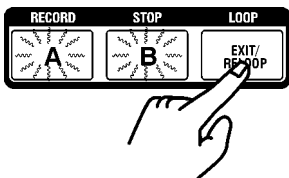

The Loop can be played again any time by pressing the [EXIT/RELOOP] key.

8.1.2. Recording using Auto-Loop function:

It is a little problematical to fix the end point of a Loop manually exactly at the first attempt. The Auto-Loop function of the BPM Studio helps at this, while it automatically record a tact exactly and then switches into the Loop-Play mode. Use the Auto-Loop function as follows:



The DirectCue information cannot be loaded into the Player in the Autofade Mode. Please do NOT use this mode if you want to use stored DirectCue's.

Set a start point at any position by pressing the A key. After that A key lights in orange.

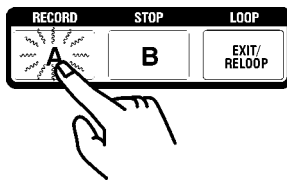

Switch now to the Edit mode pressing the [CUE] key ([CUE] key will light in red) and then the A button. A key will start to blink. (This is usually the Edit mode for the start point).

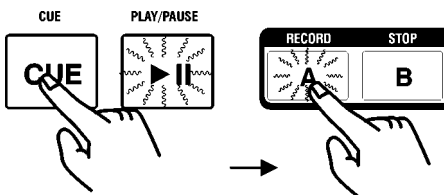

Press the B key. A Loop with exactly one tact (4 beats) is created automatically and played instantly.

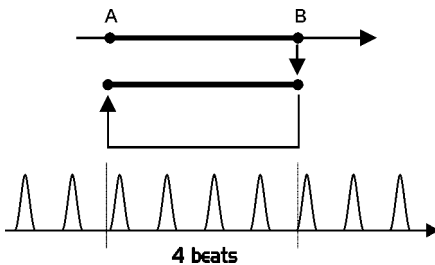
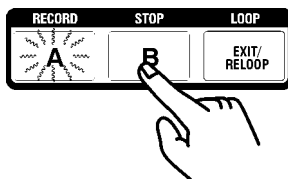



Now the **B** key and the **[EXIT/RELOOP]** key will light in green.+

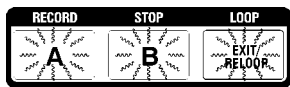

Now, using the Tact-Stepping function (ring of Jog Shuttle Wheel). you can make the Loop longer or shorter by a tact at a time. The result will be constantly played by what other interesting effects can be produced.

8.1.3. Loop storing

You can store a Loop for later use in two different ways. A Loop is at your disposal again after system restart as soon as the title is loaded into the Player.

As long as the Loop is played (A and B keys are lighting in orange and the **[EXIT/RELOOP]** key lights in green), the Loop can be stored by a DirectCue key (see also "Working with DirectCue keys"). This way up to 6 different Loops for each title can be stored and always are at your disposal, if the title is loaded to the Player. If the Loop should be at your disposal as well when another title is loaded, you can store it in the Sample Player.

8.1.4. Loop storing by a DirectCue key

The Player has to be in Loop-Play mode (Step 2 on the previous page).

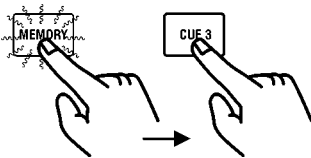

Press the **[MEMORY]** key [13], next followed by any of 6 DirectCue [15] keys.

After that this key will light in orange, what indicates that there is a stored Loop (Cue-Points will be shown by a red key). The stored Loop can be activated any time by pressing that key. Thereupon it will be taken to the Loop Player (keys [6] to [8]) and started. Also editing functions are once more at your disposal as usually.

8.1.5. Loop storing by a Sample Player key

The Player has to be in the Loop Play mode (Step 2 on the previous page).

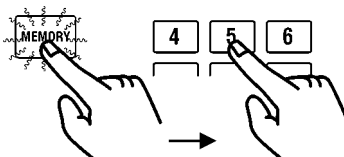

Press the **[MEMORY]** key [13], next followed by any of 9 keys of Sample Player [28]. Now, the Loop is at your disposal any time in the Sample Player by this key. Please, pay attention however that it is not automatically a new independent Sample. As soon as original title is deleted or displaced from the system, the Loop gets lost.

8.1.6. Deleting of the Loop Player

Hold the **[MEMORY]** key [13] and press simultaneously the A key of Loop Player [6]. Release all three keys and the sample will be deleted (Deleting works also using the **B** key or **[EXIT/RELOOP]** key).



Store the Loop by creating a real sample. For this you can open the File Editor of the corresponding Sampler key. The Loop will be displayed here automatically by start- and end-marker. Extend this area, select it and then choose "Export Selection" in context menu. Then, you can load the stored sample the usual way into the Sample Player.



8.1.7. Editing a Loop

Recorded Loop can be edited and changed using the Loop Player. Therefore the Player has to be in the Cue mode. Therefore press the Cue key [4]. Now, all the three keys of the Loop Player light in orange and Cue key shines in red:

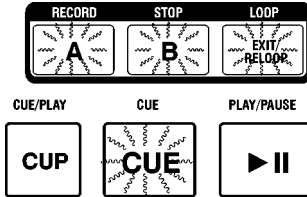

Replacing of the start point (A):
Press the A key [6] now.

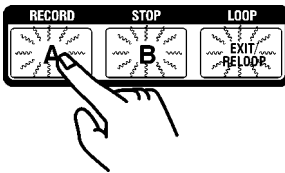

After that this key blinks and 160 ms after this point will be played repeatedly as Loop. (This Cue mode is equal as editing of the Cue points. See also chapter "Beat matching using the BPM Studio"). In the title display "MOVING-> A" will be shown additionally and the exact time of the start point. Now, you can move the point using the disc of Jog Shuttle Wheel:

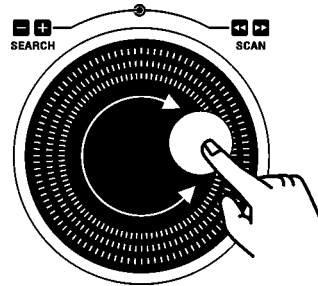

8.1.8. Beat-Stepping

Hold the [LOAD] key [11] pressed and additionally turn the disc of Jog Shuttle Wheel, then you can move the A point exactly one tact (per 4 beats).

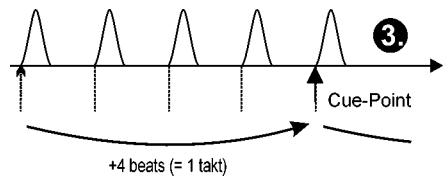
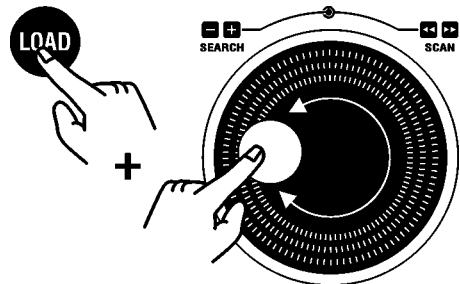

We recommend to store the BPM value, exactly determined by the Realtime BPM Counter earlier, using the key combination: **[MEMORY] + [SET]**. It decreases possible differences of those positions in the title, where Beat cannot be predetermined exactly.



If you hold the **[LOAD]** key [11] pressed, you can navigate with the Pitch Bend buttons exactly one beat forward or reverse.

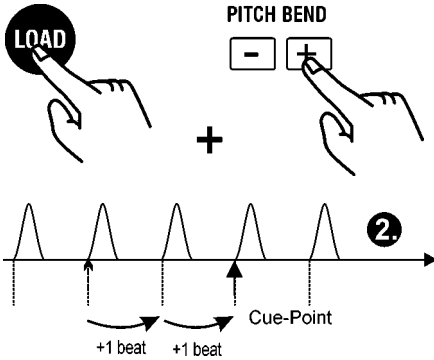

Press again while the A key is still blinking to transfer the changes.

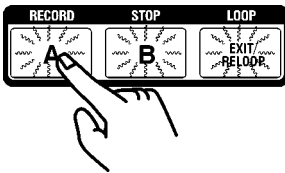

You can also change the exit point equally by pressing the **B** key in Edit mode or start the Loop by **[EXIT/RELOOP]**, for example for preliminary listening. In every case, edited points are taken over.

Read chapter "Beat Stepping" in this manual, where you will find more about the way of how to work exactly with these functions.



If the Player is in Cue mode (for example by editing a normal Cue-Point), then this point can be taken over immediately as a A point. Then, by pressing on the A key, you will arrive at once in Edit mode for the start point.

Replacing of the end point (B):

The Player has to be again in Pause mode. Press the **B** key [7].

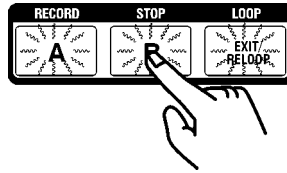

After that this key will blink and the complete Loop will be played. In the title display "**MOVING-> B**" will be shown additionally and in the time display the total length of the Loop, and the time between A and B as well.

Now you can displace this point by the disc of the Jog Shuttle Wheel.

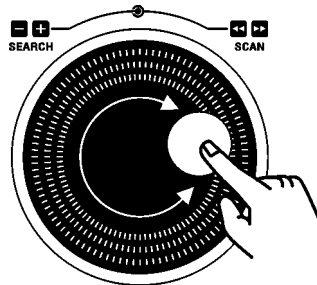

This way an exact correction of the Loop is possible, for example if the end point was not exactly met during the first setting.



Shifting of the end point by tacts (Tact-Stepping):

Using the ring of Jog Shuttle Wheel, the end point B can be moved in Edit mode by tacts (exactly 4 beats).

This means it is presupposed that the title is a 4/4 tact. Also at a 2/4 tact, efficient results can be reached, however not by titles with 3/4 or 6/8 tacts.

(1.) The Player is in Edit mode for the exit point (B blinks).

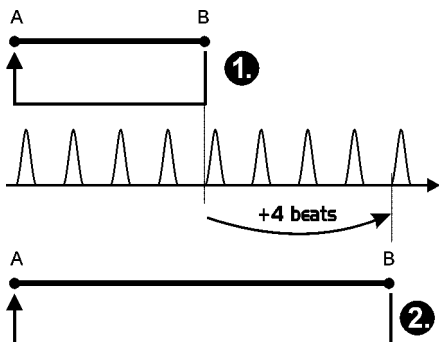

Move the ring of Jog Shuttle Wheel to the right stop.

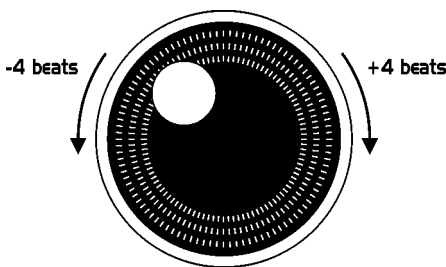

Now, the point of exit is moved behind by exactly 4 Beats (= 1 tact in 4/4 tacting) (2.) and the Loop has been extended by 4 beats consequently. You can repeat it as many times as you wish or reduce the Loop once more.

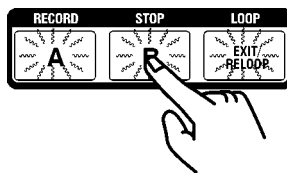

Press again on the still blinking B key to take over changes.

You can also change the exit point equally by pressing the **B** key in Edit mode or start Loop by **[EXIT/RELOOP]**, for example for preliminary listening. In every case, the edited point is taken over.



It is necessary, to store the BPM value, exactly determined by the Realtime BPM Counter earlier, using the key combination: **[MEMORY] + [SET]**. It decreases possible differences of the positions in the title, where Beat cannot be predetermined exactly.



8.2. Working with DirectCue buttons (only Remote Control RCP-2001)

The BPM Studio offers beside the standard Cue function additionally 6 Direct-Cue keys. Therefore it is possible to store up to 6 favourite positions in any title on-the-fly as Cue-Point. Then, these points can be called up without delay by a single press of a Direct Cue key. All the stored DirectCue points are available after system restart and at your disposal after the title is loaded again. With the Remote Control Units RCP-2001 you have comfortable access via the Direct-Cue keys 1 to 6 [15]. In the user interface of the software (only the BPM Studio Pro from Version 4 on up) all DirectCue points will be shown alternately in the title display. Read first how to use the Standard Cue-Funktion.

8.2.1. Define a Standard Cue-Point

The Player is in the Play mode, [PLAY/PAUSE] key [5] enlightens in green.

Press the [PLAY/PAUSE] key, then the Player is in Pause mode, [PLAY/PAUSE] key blinks in green and indicates that the Player is stopped at the paused Play position.

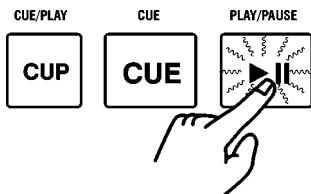

A new pressing of the [PLAY/PAUSE] key [5] allows you to continue the playing of the title. Simultaneously, this PAUSE position will be stored as Cue-Point.

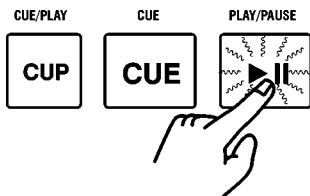

If you activate now the [CUE] key [4], then the Play position is set on this CUE point and the Player is switched to CUE. Now, the [CUE] key [4] lights in red and indicates, that the current Play position is at the CUE point.

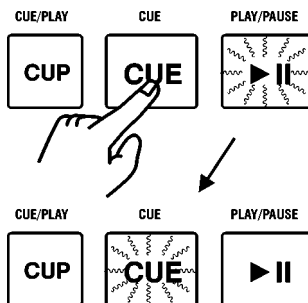

By pressing the [PLAY/PAUSE] key [5] starts the Player from the CUE point.

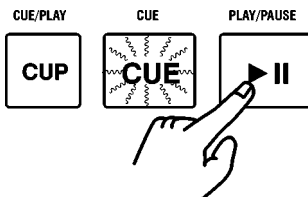

Now, you can stop the Player any time by pressing the [CUE] key [4] and set it back to Cue-Point position, in order to start it again by using the [PLAY/PAUSE] key [5].

8.2.2. Editing of a Cue-Point

If the CUE point was not exactly hit by the [PLAY/PAUSE] key [5], then it can be corrected later. Therefore the Player has to be in CUE mode, the ([CUE] key [4] lights and in the display the current CUE point appears (for example 01:22:43)).

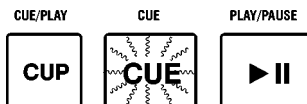

Now, move the disc of the Jog Shuttle Wheel [2]. The [CUE] key [4] is **extinguished** and 160 ms will be played as Loop repeatedly from that CUE point. (See also chapter "Beat-Matching with the BPM Studio").

Now, you can displace that point using the disc of the Jog Shuttle Wheel:

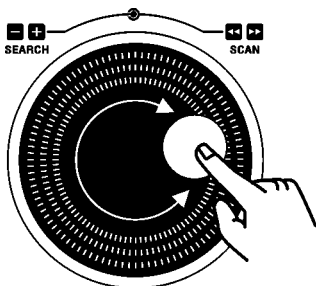

8.2.3. Beat-Stepping

Hold the [LOAD] key [11] pressed and additionally turn the disc of the Jog Shuttle Wheel, then you can displace a Cue-Point one exact tact (4 beats each).

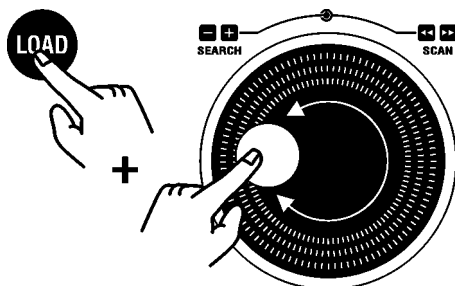

If you hold the [LOAD] key [11] pressed, then you can navigate with the Pitch Bend keys each time exactly one beat forward or reverse.

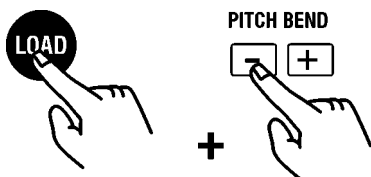

Press again and then the corrections will be stored by the [CUE] key [4] and the Player remains in Pause Mode.

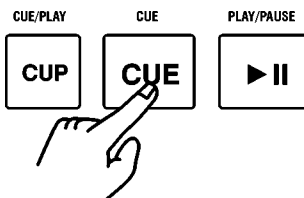

You can also immediately store corrections by pressing the [PLAY/PAUSE] key [5] and start the Player at once from this corrected Cue-Point.



Edit of a Cue-Point with the Remote Control Unit RC V3 or the software can be made by using the Search keys [43] and [44].

8.2.4. Storing of a Cue-Point by a DirectCue key

(Available only with the BPM Studio Pro Software and only included with the Remote Control Unit RCP-2001)

Every CUE point can be stored by a DirectCue key for later use. In this case the Player has to be in CUE mode (the [CUE] key [4] lights and in the display the current CUE point appears (for example 01:22:43)).

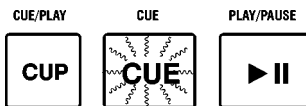

Press the [MEMORY] key [13] above the display. Now, this one enlights for 10 seconds in green.

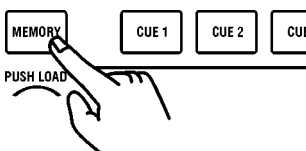



Press the Direct Cue key within this 10 seconds to store the Cue-Point onto this key.

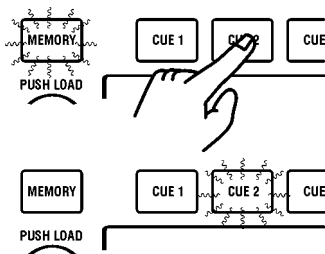

The **[MEMORY]** key [13] is extinguished and the selected Direct-Cue key lights in red. Now, the title can be started any time from this point by pressing the Direct-Cue key.



The DirectCue points cannot be loaded into the Player in Autofade Mode. Please do NOT use this mode, if you want to use stored DirectCue's.

8.2.5. Setting DirectCue points on- the-fly

You can store Cue-Points directly to the DirectCue keys, while a title is played. Simply press the **[MEMORY]** key [13] during play and then at the desired time point (but within 20 seconds) on the selected DirectCue key. Each pressing of DirectCue key prolongs the holding time of the **[MEMORY]** key by 20 seconds.

8.2.6. Editing of DirectCue points

Start the title to edit the DirectCue point by pressing the corresponding DirectCue key.

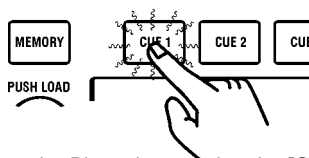

Then stop the Player by pressing the **[CUE]** key [4]. Now, you can edit the Cue-Point as written on the previous pages. Changes can be transferred by using the key combination **[MEMORY]** and pressing the corresponding DirectCue key anew.

8.2.7. Deleting of Direct-Cue points

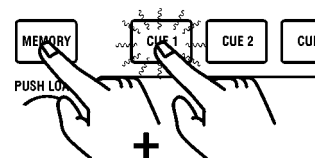

Hold the **[MEMORY]** key pressed and then press the Direct-Cue key you wish to delete within 3 seconds.

8.2.8. Deletion of all DirectCue points and the Loop Player

Hold the **[MEMORY]** key pressed longer than 3 seconds. Then, all the 6 DirectCue keys and the contents of the Loop Player will be deleted.



By a Checkbox in the program options you can prevent that pressing a DirectCue key will result in an immediate start of the Player by a Cue-Point or a stored Loop, if the Player is in the Pause or Cue Mode. If the Checkbox "Cue Memory Direct Start" is deactivated, then Cue-Points are merely taken into the Player and primarily started by the **[PLAY/PAUSE]** key or the **[EXIT/RELOOP]** key.



8.3. Beat-Stepping

(nur RCP-1001 und 2001)

Based on the exact BPM values of the Realtime BPM Counter you can navigate unrestricted within the exact Beat Raster of the title as soon as a Cue-Point has been singly synchronized to a beat. This possibility can be useful by editing Cue-Points and start or end points in the Loop Player. *All the following functions are only practicable if the Player is in Cue Mode or if the Edit Mode of the Loop Player is activated. Read corresponding chapters of manual how Beat-Stepping can be especially applied.*



(1.) A usual change of a Cue point will move it constantly forward or backwards. This way also the first Cue-Point will be defined for the Beat-Stepping resp corrected. You can use the disc of the Jog Shuttle Wheel to displace a Cue-Point.

(2.) Using Beat-Stepping you can navigate through the title by beats beginning from a already defined Cue-Point.

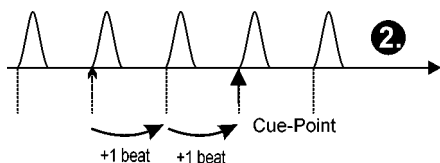

It is necessary to store the BPM value determined exactly by the Realtime BPM Counter earlier, using the key combination: **[MEMORY] + [SET]**. It decreases possible differences in the positions of the title, where the Beat cannot be predetermined exactly.

This can be attained by simultaneous holding the **[LOAD]** key and pressing any of the Pitch Bend keys:

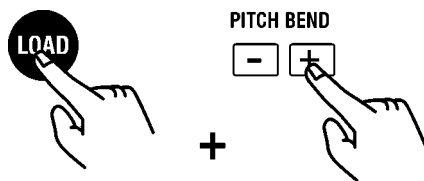

(3.) By using Tact-Stepping you can navigate through the title by tacts (4 beats each), beginning from a already defined Cue-Point.

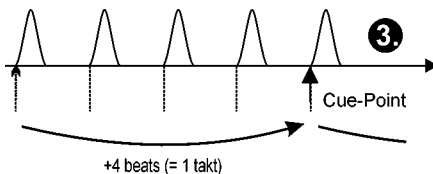

Therefore hold the **[LOAD]** key [11] pressed and turn the disc of the Jog Shuttle Wheel.

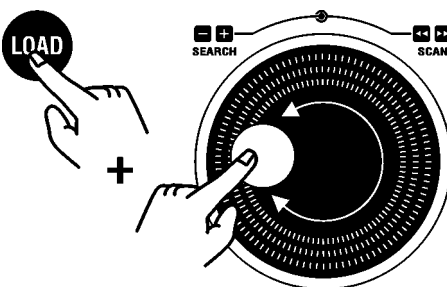

While the Player is in Cue mode, each time 160 ms will be played from the Cue-Point repeatedly as a Loop. (See chapter "Beat Matching with BPM Studio").



9.I. Keyboard use

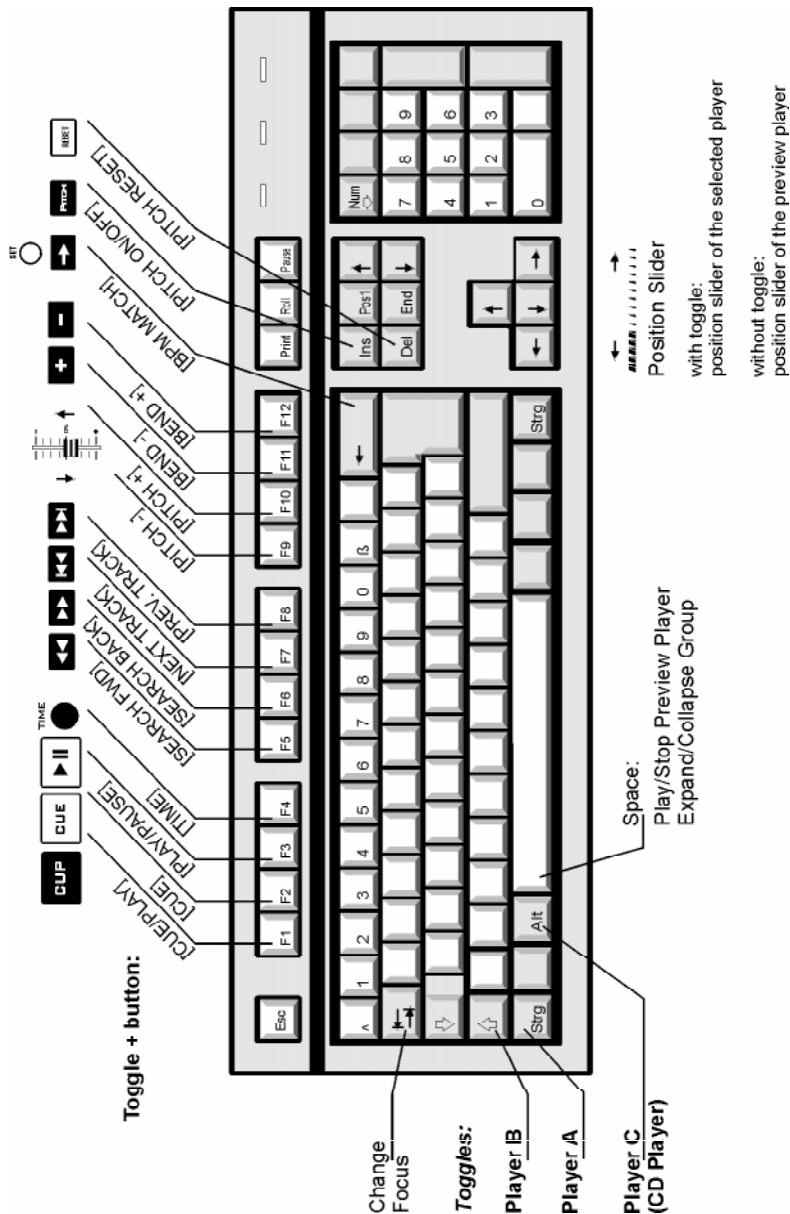



General functions:

Menu key: opens the context menu

Insert:

1. Add records to the list with focus
2. Add new group
3. Alt+Insert: Add new subgroup

Space: Play/Stop Monitor
oder Expand/Collapse Group

F1: Help

CTRL-P, SHIFT-P, ALT - P:

Loads a track from a selected playlist into a respective Player (CTRL for Player A, SHIFT for Player B, ALT for CD-Player) by inserting the selected title into the playlist of this player after the current loaded title.

CTRL-Q, SHIFT-Q:

Loads a track from the FileArchive into the left or right playlist (after the selected title in the playlist)

ALT - Q:

Loads a track from the FileArchive into the Waitlist (after the selected title in the Waitlist)

Other functions:

Toggle + P: Load selected Track into Player
Toggle + Q: Load selected Track in Playlist
Toggle + Y: Pitch reset
Toggle + Z: Pitch on/off

Clipboard functions (Windows compatible):

CTRL-A: Select all
CTRL-C (CTRL-Insert): Copy
CTRL-V (SHIFT-Insert): Paste
CTRL-X (SHIFT-Delete): Cut

Alt + A: AutoFade on / off
Alt + B: BPM counter
Alt + C: Clear List or Clear Groups
Alt + D: Load Directory
Alt + E: File Editor
Alt + F: Start Manual Fade
Alt + G: Show Group-File Archive
Alt + H:
Alt + I: File Info Box
Alt + J:
Alt + K:
Alt + L: Load list (or load files into File Archive)
Alt + M: Show Mixer
Alt + N: Normalize
Alt + O: Options

Alt + R: Show Ripper
Alt + S: Search files
Alt + T:
Alt + U:
Alt + V:
Alt + W: Waitlist / PlayList
Alt + X: Exit

Sampler's control:

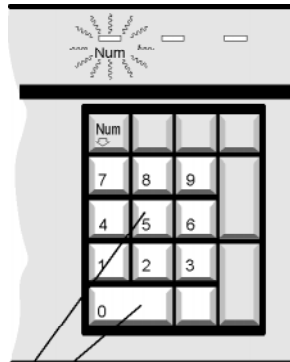

Sample button
(stops all samples)

Sample buttons to



9.2. Tips and Instructions

General information:

The different virtual devices of BPM Studio can be put on two different sound cards, respectively one multi-channel sound card. Assignments are made in the Audio I/O section of the Program Options. Usually BPM Studio works with all sound cards serving DirectSound, installing one driver for all available channels.

If you experience any problems, you should at first (as a rule) load the newest driver for your sound card, searching for it on the Web Site of the manufacturer. Normally drivers are continuously updated and as the sound card is the most important system component for BPM Studio, you should regularly check if a new driver is available.

ALCAtch recommends and tests actual sound cards for Windows 98 systems, however we cannot support NT or 2000, so we recommend to use Windows 98 resp ME. Most sound cards are anyway not equipped with useful drivers for those systems and they might have some disadvantages opposite to Windows 98/ME. They are suitable as server operating systems, but for multimedial purposes they are completely unsuitable.

Several sound cards in one PC:

(This information concerns the „normal“ sound cards with one stereo output, for example Soundblaster, Terratec etc.).

Sound card driver usually can support only one sound card. They do not recognize the presence of 2 identical sound cards in one PC. So, as a rule you should use different sound cards. If actual driver by Creative Lab from November '99 shall be used, these drivers must be from other manufacturers, for example SB-Live and Terratec DMX. The preference should be given in any case to a multichannel card, because they are essentially more simpler to install and mostly cascable.

The distribution of resources:

The BPM Studio evaluates all frames of a MP3 file and needs therefore a little more resources than other simple MP3 player as WinAmp™ for example. BPM Studio has essentially a much greater function range than this player and a direct comparison does not make any sense. So, we should point out, that all sound cards possess their own, free IRQ and that is no other card or PC element uses it.

Also other components like hard disk, CD-Rom or graphic card play a role which is not to underestimate for the total performance of a system. It is also recommended to use a PC exclusively for BPM Studio (for professional use).

Driver latency:

Under „latency“, we understand the „delay“ between a command as for example 'Play', 'Pause' or 'Stop' and the moment the sound card reacts to these commands and begins play for example. Fundamentally 'latency' depends on the used driver type and partially on the driver too. As lower the latency of a driver is, the more qualified is the driver for exact Beat-mixing.



More information, description of our current sound card tests, program updates and answers to frequently asked questions (FAQ), can be found on our web site: www.alcatech.com



Contact, support

ALCATEch GmbH assures the technical support by e-mail and fax. Your questions by e-mail please send to support@alcattech.de or by fax to +49 3675 4201 20.

Please remember to give your Registration number and program version. We will be glad to receive your suggestions to improve this manual.

Updated: 06/14/2001.



9.4. Glossary

Application

Software programs that perform different tasks that otherwise wouldn't be accomplished by an operating system itself. Examples of such applications are: a text-editing program such as Microsoft WORD, a bookkeeping program and BPM Studio.

ASF

Abbreviation for Advanced Streaming Format. It is a streaming format for files developed by Microsoft.

Beat

A repeating sound that defines speed and tempo of a title and is normally produced by an instrument such as a drum for example.

Bit

A Bit is the smallest unit for binary data. With a Bit exactly two different states (0 and 1) are representable. (Bit = binary digit). A Bit is also a position in the dual system. Most of the PCs and also the modern information technology are based on this numerical system.

Bit Rate

The bit rate is a measure for the transmission speed of binary information. The scale unit for the bit rate is bps (bits per second, number of transmitted bits at one second). The maximal bit rate of a connection is also named as "bandwidth". As greater the bandwidth, as bigger is the transmission speed. Some standard bit rates are e.g.: 96 Kbit, 128 Kbit, 196 Kbit, 244 Kbit. As higher bit rates allow to transfer more information a better sound quality is obtainable. But a higher bit rate is always associated with a higher demand on memory space, as you have to store more information as well.

Buffer

A memory space where data is held temporarily before final treatment. BPM Studio loads the title from the hard disk into the buffer for a few seconds and then uncompresses it before the sound card receives it. Thanks to this action, no lockups or other malfunctions occur.

Configuration

"To configure" means to adapt the hardware and software to meet your own needs. BPM Studio has a lot of possible different configurations in the program options context menu. Please, read the program options section in this manual for a detailed description of each selection.

Constant Bit Rate

It means simply that the bit rate is not changed during the copying or encoding. (See VBR also - Variable Bit Rate)

Cue

A cue is a position within a title that the player recognizes as a beginning point. BPM Studio makes it possible to set up different Cue-Points for a title. You can also start playing within a title from this place.

Cursor

Symbol which shows on the monitor the position of the next input. The traditionally cursor (e.g. at a DOS operating system) was displayed as a simply, blinking underline. Since the era of graphical user interfaces and operating systems the cursor can change its design in accordance with its function.

Desktop

The desktop or the background is what you see on your computer monitor before you start any other programs. This is the place where you start to work with other programs or files that you may open.

**Dialogue box**

The Dialog box is a window that you can use to communicate with the computer or application. Dialog boxes give you information on the progress of a working application and offer you the option to put that information to the use in the application. For example BPM Studio will show the program options as a dialog box.

Directory

A directory is an area on the hard disk designated for storage for data files and other directories. As an example, you would store all of your music titles in a directory.

Driver

A driver is a program that determines how a computer will communicate with a peripheral device such as a sound card or video card. The manufacturers of the peripherals create the drivers. We recommend always visiting the manufacturer homepage of your sound card and other peripherals to find the newest information about their drivers.

Dynamics

Dynamics (or dynamic volume) in regard to sound is a range between the smallest and the greatest value of volume (the softest and the loudest position). If the possibility to copy or play silence or loudness is greater, then greater the dynamics will be. It is also valid in the same way in the recording of audio signals.

Encode, Encoder, Encoding

To encode (code) means to transfer messages or files into an encrypted form. Code is a system of rules that is applied to transform a message into an impossible form so that it can only be read by authorized persons (normally to keep a message in secrecy). Another way to encode is by decreasing the number of determined rules used by an application with regards to huge data transfer without a considerable loss of content. MP3 files are created as audio files by using an audio Codec that holds only a fraction of the original size of the file. The reading of AUDIO CDs is also called 'ripping'.

In this process, titles are copied from the CD as WAVE files to the hard disk. Then, an encoder will read these files and transform them into MP3 FORMAT. BPM Studio also offers the option to encode the CDs into MP3 format immediately during reading ('ripping'). You can activate that option (rip and encode) in the program options -> option CDDA.

Encryption

Data translation into an appropriate code to protect information against unauthorized use by other persons. To be able to read coded files, you must to have access to a code (or to a password) that authorizes you to decipher the coded information.

File

Data collection (based on an application or program) of a determined type put on a computer, on floppy disks, on CD etc. Each file is stored under an attributed name so that it's quick to find for later use.

Format

This is the preparation of a data medium (for example: a hard disk) to store files. This is usually done during the first installation of an operating system on a hard disk. It is also done to any additional hard disk in a PC.

Format is a word that determines arrangement based on rules. For example, there are left hand and right hand text formats and there are determined audio file formats like WAVE, MP2 and MP3.

Icon

A small image on the Desktop that symbolizes or represents a program or file. You can see examples of different icons on your Desktop. Normally, they are arranged on left side of the screen as 'Recycle Bin', 'My Computer', and 'My Documents'. They are also called 'shortcut icons'. Programs associated with an icon will start by double clicking on the icon.

**ID3 Tag**

This is a feature of MP3 technology that gives the user the possibility of storing information regarding the MP3 within the MP3 itself. Basically, there are two types of ID3 tags: the old ID3-Tag, which is the fundamental tag and also the ID3V3 tag, which is a more developed tag. BPM Studio supports both formats and gives you the option to choose the one you want to use. We recommend using the ID3V3 Tag, because it can contain much more information than the original tag. The choice for which tag is used is made in the program options.

Interface

This is the medium between hardware, software and the user. Basically, it allows the user to communicate with the PC in a simple way.

Joint Stereo

This means that the encoder dynamically chooses an encoding algorithm according to the contents of the audio file for each separate frame. This way each frame is encoded with the best possible quality. The file size is simultaneously reduced thanks to a better compression ratio. These files are also known as VBR files. BPM Studio can play these files without any problems.

Kbit (kilobit)

A kilobit corresponds to 1024 bits (1 kBit = 1024 bits). The BPM Studio glossary definition should not be confused with the metric system definition where kilo is 1000.

Metronome

This is a device that utters a fixed or continual sound (Tick, Whistle or blinking light). It is primarily used by musicians to maintain a desired beat or play speed of a title so that it is not slower or faster than what is designated.

Midi

Midi is a serial communication protocol between electronic musical instruments and effect devices. It serves to enlarge the sound capacities of a device. An example of this would be a PC with MIDI software.

Modem

This makes it possible for a PC or similar device to connect to the Internet through a telephone line. A modem (MOdulator / DEModulator) transforms digital signals from the PC into analog tones in preparation to send them across telephone lines. This is needed because traditional telephone lines can only support analog signals. Modems are mostly used to connect to the Internet. There are also modems that send data digitally. An example of this type of modem is an ISDN modem. ISDN works on a dedicated digital telephone line instead of an analog line.

Module

Hardware or software that is a part of a bigger system and represents influences to this system. A software module is a program that is developed to take over a specific part of a bigger program. The virtual Player, Mixer and CD - Player/Encoder are modules of BPM Studio. These modules are available in some or all versions of software.

MP3

This is a file format developed by Fraunhofer IIS in Germany. It contains compressed audio and ID3 tag information. MP3's are intelligently compressed and are adapted to the sensibility of the human hearing and acoustic susceptibility. It dynamically takes away all of the redundant, non-essential and not perceptible information and only stores the necessary information for Hi-fi quality play. The file size can be minimized to 1/8th and 1/19th of the original Wave file size. Thanks to the MP3 Format, it was possible for the first time to transfer music through Internet in Hi-fi quality with minimal download times. Larger and larger hard disks make it possible to store more music titles directly on your computer. As a result of all this, it was possible for BPM Studio to be developed and introduced as a MP3 technology into the DJ field.

Parameter

A parameter is a factor that determines a range of variations. By adding parameters to the end of a program command line, you can make the program run differently. A few examples of parameters in BPM Studio are: buffer size, data path and compression rate.

**Peripheral**

An auxiliary device, such as a printer, modem, storage system or external Remote Control Unit that works in conjunction with a computer.

Pitch

Professional CD players allows the user to change the playback speed of a track. This is necessary e.g. for synchronizing two titles with different speed (BPM - beats per minute) resp. playback with the same speed. The measure of the changed speed in contrast to the original speed is called "pitch" and is stated in percent. A pitch value of +100% means that the title will be played with the double speed, -50% plays the title with the half of the speed.

Pitch Bend

Using the Pitch Bend function a temporary increasing or decreasing of the pitch is possible. This is useful if two titles, already played back with the same speed, shall be synchronized in beat. By pressing a Pitch Bend button the speed will be increase or decrease continuously. At releasing the button the title returns continuously to its original speed as well. With the Pitch Bend buttons the beats of two titles can be synchronized exactly and very small corrections of both players are possible.

Rip, Ripping

Ripping is act of reading an Audio CD using the CD-ROM drive of a computer and storing the information onto a hard disk. IBM PC's use the Wave format for ripping and Mac computers use the AIFF format. The generation of an MP3 file can happen either after a rip or simultaneously as the rip is being performed.

Root Directory

When a floppy or hard disk is formatted for use, this particular directory is created. It is called the Root Directory. It contains important systematic files and is the first level for subdirectories.

Selection box

This is a text box that enables a choice between 'ON' and 'OFF' or 'Yes' or 'No'.

Subdirectory

This is a directory within a directory. Subdirectories are used to organize files. This makes it easier to find files.

Tempo

Tempo is the original speed of a title. The song writer or interpreter defines this speed. With the Pitch function of most professional CD players, and BPM Studio as well, this speed can be changed in a wide range.

Text field

This is a rectangular box where text can be entered. There are many different ways to use these Text boxes for example: changing standard text entries or other pretending text (if the change is allowed), entering necessary program information to enable the program to work and also editing title entries in the ID3V3 tags for later use.

Track

We refer to a Track as recorded title, a piece of music or a song.

VBR Files

Compared to CBR (Constant bit rate), the encoder analyzes the title's VBR (variable bit rate) and chooses an exact compression algorithm for every frame adapted by the MP3 encoding. This allows for better compression at higher bit rates compared to the compression of a simple signal or CBR.

WAVE file

This format is used by Windows to store audio signals free of sound quality loss. Examples of sources of this sound quality could be: Audio CD's, Film soundtracks and records. All signals are copied exactly. The quality in the WAV file is the same as in the original data. But, in order to have this kind of quality it is necessary to have a large amount of free hard disk space.



© 1999-2002 by ALCATech GmbH. All rights reserved.

BPM Studio user manual for Windows

This working manual as well as the software described in it are part of the license agreement and can only be used or copied in accordance with conditions of the license and it is not considered as an ALCATech GmbH obligation. ALCATech GmbH does not give any guarantee or warranty in regard to the correctness and/or exactness of the contents of this manual. No part of this license can be reproduced, stored in data banks, or transferred in any other form, whether it be electronic, photomechanical, on sound media or in any other way - unless by the electronically-agreed license, without prior written permission of ALCATech GmbH.

License conditions:

The program and all its parts are copyright protected. The buyer is granted the right to use the program on one computer. This right is not transferable, rentable or distributable. It is forbidden to change, duplicate, rent, transfer and use the contents of the

CD-ROM on other data storing media. All authors and productive rights reserved. ALCATECH GmbH takes no responsibility for any damage caused by the use of the CD-ROM. Before installing any new software programs (including BPM Studio) on your computer, you should make a backup of your files. Intel is a registered trademark of the Intel Corporation. Pentium, Pentium II and Pentium Pro are trademarks of the Intel Corporation. Microsoft, Windows, Windows 95, Windows 98, Windows 98SE, Windows NT and Windows 2000 are registered trademarks of Microsoft in the USA and other countries. All other trademarks are property of their respective owners.

Composed and designed by ALCATech, Germany.

Copyright © 1999-2002 ALCATech GmbH,
D-96515 Sonneberg, Otto-Bergner-Strasse 30, Germany.

Internet: www.alcatech.de · www.alcatech.com

Printed in Germany

