

INTRODUCTION

Page 2

PNP GUIDE

Page 4

LOUDSPEAKERS

Page 7



ELECTRONICS

Page 37



ACCESSORIES INSTALLER TOOLS VOLUME CONTROL PAGING MICROPHONES

Page 69



SOLUTIONS

Page 75



INDEX

Page 80

Introduction





Welcome !

With a successful ISE and Pro Light+Sound just behind us, we'd like to welcome you to the 2010 version of the APart product catalogue.

ISE 2010 was yet another milestone in the history of APart, as we introduced MASK2 : a new model in our series of MASK cabinet speakers. A combination of cute looks and great sound, these incredibly small satellite top speakers are designed especially for use with the SUBLIME subwoofer in small to medium-sized rooms, in residential as well as public buildings.

Whether it is the inviting atmosphere of a shop or lounge bar, the tension of a white knuckle movie through a home theatre, the refined drama of opera or the kick of your favorite rock album through a HiFi system, MASK2 will fit effortlessly into any interior style and surprise anyone with its sound quality.

Further, find out more about our new series of FM/DAB+ tuners and CD/media players, and take a look at the SDQ5PIR. The active speaker set that has turned into the market's standard is now available with RS-232 and IR control and optional remote and wall panel controls.

For those situations where interior decoration does not permit cabinet subwoofers we now introduce CM-SUB, a build-in subwoofer with exactly the same looks as our stylish series of 8" ceiling speakers. And, because we are always thinking of installer-friendly solutions, you will find a full range of back boxes to go with all our models of square and rectangular build-in speakers. A brand new line up of cables that weren't on the market previously will save you precious time – no more soldering !

Finally, ask your APart distributor for our new Plug & Play audio guide. A 100 page guidebook for the fixed install audio market. Take a look at the sample pages coming up right behind this introduction. The guide will help you deepen your knowledge on Installed Sound or will help you to get started. Best of all, it will give you the opportunity to take up projects you have always considered out of reach. Enjoy !

The APart team



Get your head out of the box, and discover how APart can drive your business. Start using our unique plugNplay guide! 100 pages of practical installed audio information : FAQ about installing audio, a comprehensive index to help you find the most appropriate example for your project and more than 40 case studies where we explain which audio installation works best for your project. We walk you through the set-up, explain which speakers to use at what power setting, which electronics to use and how to wire the system. The guide will help you with installations, and will make you win projects you've always considered out of reach. Ask your APart distributor for it now!

Production hall

Area : 850m² - 1400m²

Situation

- Production hall, offices, cafeteria, loading dock : 1000m²

Customer requests

- One system versatile enough to cover the entire facility
- Powerful enough to ensure clarity of messages and music even in a noisy production area
- Outdoor speakers weatherproof and rustfree
- Speakers in the office stylish and fitting with the interior
- Different music in production area compared to office, loading dock, cafeteria and toilets
- Independent volume control for offices, reception production, cafeteria and loading dock

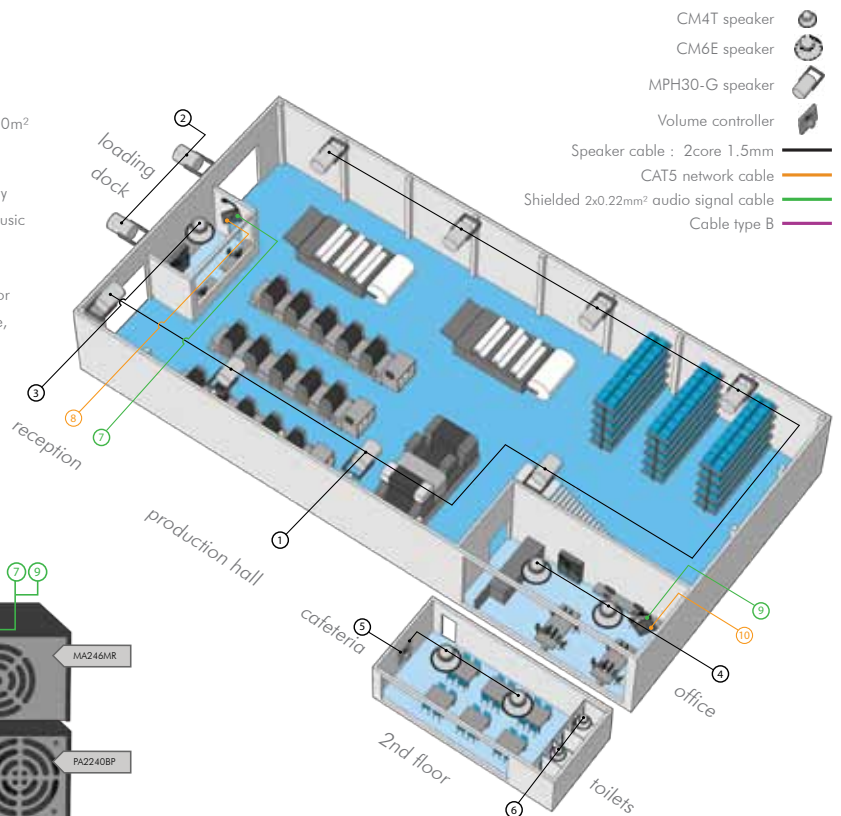
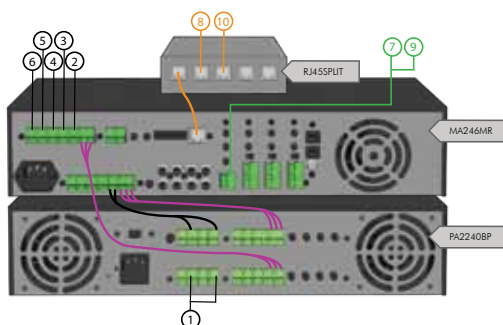



SPEAKER CHOICE STEP ONE

- CM4T : 4.2" ceiling speaker
- CM6E : 6.5" ceiling speaker
- MPH30-G : horn loaded sound projector

Zone	Surface in m ²	Speakers	Speaker power setting	Colour
production hall	600-1000m ²	8 x MPH30-G	30 Watts	●
loading dock	150-250m ²	2 x MPH30-G	30 Watts	●
reception	15-30m ²	1 x CM6E	6 Watts	○ ● ●
office	30-60m ²	2 x CM6E	6 Watts	○ ● ●
cafeteria	30-60m ²	2 x CM6E + E-VOL40	6 Watts	○ ● ●
toilets	20-40m ²	2 x CM4T	3 Watts	○ ● ●

Is the project you are working on bigger than the production hall in this example?
Check the other case studies in the corporate section of this book, or contact your APart dealer.
He will help you to work out a project that exactly fits your clients requirements.

ELECTRONICS CHOICE STEP TWO

- MA246MR : 100 Volts mixing amplifier with radio & CD/MP3 player
- MICPAT-6 : selective 6-zone paging microphone
- RJ45SPLIT : to connect multiple paging microphones
- PA2240BP : 2 x 240W / 100V amplifier
- E-VOL40 : 100 Volts volume controller

Max. total power consumption of this installation : 1000 Watts

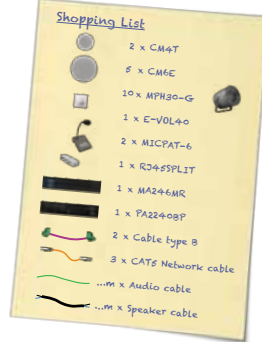

Production hall , Small factory , ...

Corporate



APart

Affordable quality audio solutions create possibilities !

APart products are very competitively priced. These prices give APart installers a stronger position in a competitive market.

But what's more : we give you the opportunity to deliver an even better project. Because prices are always under pressure, many installers do not allow for some extra power reserve in their sound system. sometimes none at all. This may result in a competitive offer, but sadly also in a sound system that does not perform well. APart allows you to count in that extra headroom and install those extra speakers for better sound coverage.

Hi-Fi and consumer audio is not designed for pro-applications !

Are you also sick and tired of having to install an unreliable consumer hifi system instead of the professional solution you really wanted? (The one your customer saw at the electronics megastore for half the price?) In the next pages you will discover professional solutions for a price that can compete with consumer material.

Discover it now: the combination of APart quality products and attractive pricing allows you to offer, and deliver the project you really had in mind!

MUSIC & DESIGN



CEILING SERIES

Page 9-13



IN-WALL SERIES

Page 15-17



MASK DESIGN SERIES

Page 19-23



SUB SERIES

Page 24-26



SDQ CABINET SERIES

Page 27-29



SPECIALS

Page 31



OUTDOOR MUSIC SERIES

Page 32

SPEECH & FUNCTIONALITY



OUTDOOR PAGING SERIES

Page 33



SOUND COLUMN SERIES

Page 34-35

LOUDSPEAKERS



Wired for sound. APart offers a wide range of build-in speakers that fit seamlessly into any interior. The CM lineup comes in various shapes and many models are now also available in black and silver. Voice applications in boardrooms, evacuation or paging in public areas, background music in restaurants or supermarkets: there is an APart ceiling- or in-wall speaker for every possible application or purpose.

Size does matter! The smallest models in our speaker range are ideal for use in restrooms, cloakrooms, quiet areas or discrete interiors. A new 4" speaker offers the ideal combination between small size and amazing sound.

The CM6SF is protected by a metal fire dome and is your speaker of choice for voice evacuation purposes.

3" METAL MINI

- CM3T • CM3T-BL • CM3T-SLV 
- Halogen spot size, bright sound
- 3" full range speaker
- 6 - 3 - 1.5 Watts 100 V
- 20 Watts @ 16 Ohm
- PAINTCMM (option: any RAL colour)
- Dimensions: 105 (outside Ø), 82 (cutout Ø), 70 (d) mm



4" METAL MIDI

- CM4T • CM4T-BL • CM4T-SLV 
- Perfect match of size and sound
- Surprising quality for a 4"
- 6 - 3 - 1.5 Watts 100 V transformer
- 30 Watts @ 16Ω
- PAINTCMM (option: any RAL colour)
- Dimensions: 135 (outside Ø), 105 (cutout Ø), 74 (d) mm



CM6SF METAL



- CM6SF 
- Safety first ... : voice evacuation alarms
- Compliant to the EN60849 regulation
- Steel firedome included
- 6.5" dual cone woofer
- 6 - 3 - 1.5 Watts 100 Volt transformer
- PAINTCM (option: any RAL colour)
- Dimensions: 217 (Outside Ø) , 205 (Cutout Ø), 148 (d) mm

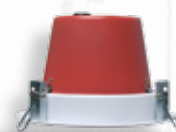

Easygoing

APart's dual cone speakers won't let you down. The CM6E is standard available in white, black and silver and can be used in any décor and style. Particularly suitable for voice applications and soft background music, the CM5E and CM6E assure constant quality while keeping your budget in check!

6.5" DUAL-CONE ELEGANCE



•CM6E •CM6E-BL •CM6E-SLV



- Start with elegance...
- 6.5" dual cone speaker
- 6 - 3 - 1.5 Watts 100 V transformer
- PAINTCM (option : any RAL colour)
- Dimensions : 205 (Outside Ø), 183(cutout Ø), 70 mm(depth)

5" DUAL-CONE BUDGET SOLUTION

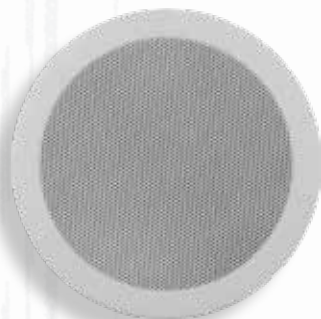

•CM5E



- Probably the most affordable in the world
- 5" dual cone speaker
- 6 - 3 Watts 100 V transformer
- Quick fit via 2 spring clamps
- PAINTCM (option : any RAL colour)
- Dimensions : 178(outside Ø), 160(cutoutØ), 53 mm(depth)



Did you know

Why APart speakers do not have back cans?

Because those cans enclose the back of the speaker, they have a negative impact on sound quality: a back can requires a bigger housing, and it makes your speaker a lot bigger than it actually is. With a 4" speaker hidden behind an 8" grille, the looks of your speaker do not match the sound. From an installer's point of view, a speaker with back can is difficult or even impossible to mount.

APart speakers are protected from dust and small debris by a rear net, which allows the air to flow freely around the speaker. This results in an elegant speaker with a full, rich sound!

Heart & Soul

These 6.5" two way ceiling speakers bring HiFi quality sound to every imaginable setting. They have a stylish design and are now available in silver and black, which makes them fit into any interior or architect's project. Aluminium grills allow applications in humid environment.

6.5" TWO-WAY REFERENCE



• BL

• SLV

•CM608 •CM608-BL •CM608-SLV

- The everlasting contractor's standard
- 6.5" enforced PP woofer, 1" tweeter
- 60 Watts program power @ 8Ω
- PAINTCM (option:any RAL colour)
- Dimensions: 205 (Outside Ø) , 183 (Cutout Ø), 80 (d) mm

•CM6T

- The contractor's reference
- 6.5" enforced PP woofer, 1" Tweeter
- 60 Watts program power @ 16Ω
- 6 - 3 - 1.5 Watts 100 Volt transformer
- PAINTCM (option:any RAL colour)
- Dimensions: 205 (Outside Ø) , 183 (Cutout Ø), 80 (d) mm

•CM20T •CM20T-BL •CM20T-SLV

- Just that little extra ...Power!
- 6.5" enforced PP woofer, 1" tweeter
- 60 Watts program power @ 16Ω
- 20 - 10 - 5 - 2.5 Watts 100 Volt transformer
- PAINTCM (option:any RAL colour)
- Dimensions: 205 (Outside Ø) , 183 (Cutout Ø), 80 (d) mm

•CMBB

- The CMBB can be used as an on-wall or in-wall back-box for the APart build-in speakers CM6T, CM6E, CM20T & CM608
- The conical shape of the CMBB guarantees a perfect fit into a concrete or brick wall or ceiling
- PAINTCM (option:any ral colour)
- Dimensions: 230 (Outside Ø) , 80 (h) mm

Speed Record

You've never installed ceiling speakers faster than the CM6QFT. This 6.5" ceiling speaker is equipped with the Quick Fit System that makes installing a large amount of ceiling speakers a piece of cake. No more fumbling with mounting screws and screw drivers on top of your ladder: count on APart for products that make an installers' life easier.

6.5" TWO-WAY
SPEED RECORD

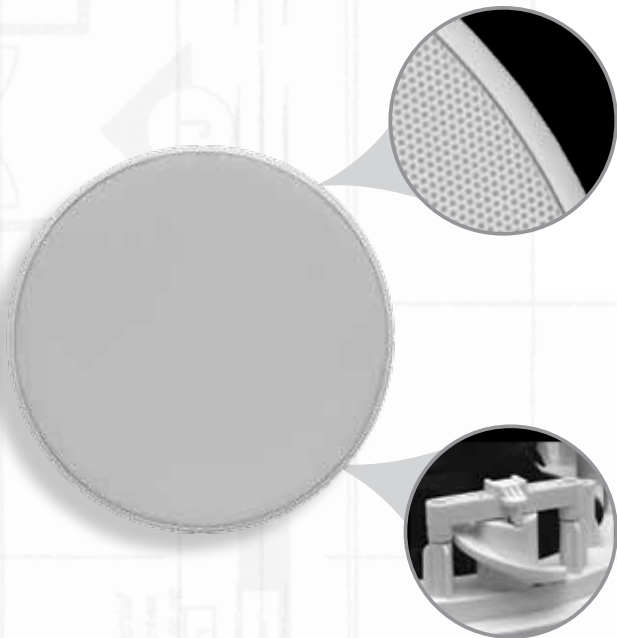

- Thanks to its sleek, flat looks and ultrathin edge, this ceiling speaker can seamlessly be integrated into any interior.

- The patented Quick Fit System allows easy installing. Connect the cabling, place the speaker in the cutout and push the clamp releases. It's as easy as that, a matter of seconds.

- CM6QFT 
- The new contractor's reference
- The patented Quick Fit System reduces install labor drastically
- Fits most ceilings 12,5 - 29mm thick
- 6.5" low-distortion paper cone woofer, 1" tweeter
- 6-3-1.5 Watts 100 Volt transformer
- 40 Watts program power @ 16 Ohm
- Strong metal grille
- PAINTCM (option: any RAL color)
- Dimensions: 237 (Outside Ø) , 216 (Cutout Ø), 65 (d) mm

High Profile

: this series of ceiling speakers bring background music to a level of perfection. The eight inch 2-way CM1008 and CMX20T offer a perfectly balanced sound, completed by the deep basses of the CMSUB. With exactly the same look as the ceiling speakers, this build-in subwoofer offers the ideal solution for situations where the interior design does not allow the use of cabinet subwoofers.

8" TWO-WAY PERFECTION



• BL

• SLV



•CM1008

- Perfectly balanced full spectrum sound
- 8" enforced PP woofer, 1" tweeter
- 100 Watts program power @ 8Ω
- PAINTCM (option:any RAL colour)
- Dimensions: 244 (Outside Ø) , 220 (Cutout Ø), 90 (d) mm

•CMX20T •CMX20T-BL •CMX20T-SLV

- When top quality does matter...
- 8" enforced PP woofer, 1" tweeter
- 100 Watts program power @ 16Ω
- 20 - 10 - 5 - 2.5 Watts 100 Volt transformer
- PAINTCM (option:any RAL colour)
- Dimensions: 244 (Outside Ø) , 220 (Cutout Ø), 90 (d) mm



CMSUB8 BUILD-IN SUBWOOFER



•CMSUB8

- 8" built-in stereo subwoofer (dual coil)
- Discrete, stylish and inconspicuous design
- Passive X-over filter incorporated
- Ideal with compact cabinet speakers and small ceiling speakers
- Active configuration: ideal with CHAMP4 amplifier
- Can be used in humid places
- 2 x 80 Watts program power @ 8 Ohm
- Dimensions : 246 mm diameter x 106 mm depth
- Cutout diameter : 226 mm



Breathe the atmosphere: 5.1 surround with a white-knuckle movie, a quality sound in your meeting room or showroom that matches your company's image, trendy background beats in the hippest location or your favorite band in your own living room: high quality sound can add so much to the experience. APart's range of hi-end Kevlar speakers stands for enjoyment!

Style & Quality

meet in the CMRQ Kevlar speakers. These in-wall speakers bring crystal clear high notes and powerful deep basses that will astound the most demanding audience. Hi-end stereo enjoyment and stunning 5.1 sensations in the home environment, or ultra-discreet quality background music in a public building. And, with their tight, flat design the CMRQ speakers are the perfect match for a wall mounted flat screen, and seamlessly fit into the most exclusive interior designs.

CMRQ108 EXPERIENCE



• CMRQ108

- Enjoy the best musical experience a wall speaker can deliver
- Top quality 6.5" woofer with Kevlar Dupont® cone
- Pivotal silk dome tweeter, very low distortion
- Built-in crossover with HF tone control
- 120-Watts program power
- 8 ohm, selectable to 12 ohm
- PAINTCM (option: any RAL colour)
- Dim. (outside): 296 (h) x 196 (w) mm
- Cutout: 272(h) x 172(w) x 78(d) mm



• CMRQ108BBI

- Backbox for IN-WALL mounting
- Dim. (outside): 351 (h) x 251 (w) x 90 (d) mm

CMRQ108C CENTER



• CMRQ108C

- Hi-end center speaker for home theatre use
- Attractive design for other use as well
- Precisely engineered for clear voice reproduction
- Dual 5.3" woofers with Kevlar Dupont® cone
- Silk dome tweeter guarantees crystal clear sound
- Built-in crossover with HF tone control
- 100 Watts program power @ 8 ohm
- PAINTCM (option: any RAL colour)
- Dimensions (outside): 176 (h) x 346 (w) mm
- Cutout: 153 (h) x 323 (w) x 69 (d) mm



• CMRQ108CBBI

- Backbox for IN-WALL mounting
- Dim. (outside): 221 (h) x 402 (w) x 90 (d) mm

Distinct

: The design and sound quality of our range of square speakers will win the heart of every sound loving interior designer. The lineup has now been completed with two new discrete 5" speakers in low impedance and 100 V. These speakers can be integrated with any interior style, whether it is a family room, bathroom or small office.

5" TWO WAY SQUARE



•CMS508

- Compact, stylish and powerful...
- 2 way : HiFi 5" enforced woofer, 1" tweeter
- 50 Watts program power @ 8Ω
- PAINTCM: (option) any RAL colour
- Dim. (outside): 171(h) x 171(w) x 54(d)mm
- Cutout: 145 mm x 145 mm

•CMS5BBI



- Backbox for IN-WALL mounting
- Dim. (outside): 221 (h) x 221 (w) x 90 (d) mm

•CMS15T



- Small format to fit discretely into any interior
- 2 way : HiFi 5" enforced woofer, 1" tweeter
- 50 Watts program power @ 16 Ohm
- 15 - 10 - 5 - 2.5 W - 100 V transformer
- PAINTCM option: any RAL colour
- Dim. (outside): 171(h) x 171(w) x 61(d)mm
- Cutout: 145 mm x 145 mm

6.5" TWO WAY SQUARE



•CMS608

- Great shapes ..., quality sound
- 6.5" enforced woofer, 1" tweeter
- 60 Watts program power @ 8Ω
- PAINTCM (option: any RAL colour)
- Dim. (outside): 201(h) x 201(w) x 75(d)mm
- Cutout : 176 x 176mm

•CMS6BBI



- Backbox for IN-WALL mounting
- Dim. (outside): 251 (h) x 251 (w) x 90 (d) mm

•CMS20T



- Looks good..., sounds great !
- 6.5" enforced woofer, 1" tweeter
- 60 Watts program power @ 16Ω
- 20 - 10 - 5 - 2.5 Watts 100 Volt transformer
- PAINTCM (option: any RAL colour)
- Dim. (outside): 201(h) x 201(w) x 75(d)mm
- Cutout : 176 x 176mm

Design

driven by reason creates power : meet APart's range of rectangular in-wall speakers. The new 4" CMR15T combines an outstanding sound quality with a distinguished look, while three 5" speakers make sure you have the right alternative for even the most challenging project.

4" RECTANGULAR

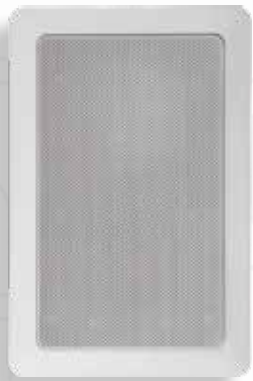

• CMR15T

- Quality sound by a small and elegant design
- 4" enforced woofer, 1" tweeter
- 60 W program power @ 16Ω
- 15 - 10 - 5 - 2.5 Watts 100 V transformer
- PAINTCM option: any RAL colour
- Dim. (outside): 220(h) x 147(w) x 60(d) mm
- Cutout: 192(h) x 118(w) mm



• CMR4BBI

- Backbox for IN-WALL mounting
- Dim. (outside): 301 (h) x 221 (w) x 90 (d) mm

5" RECTANGULAR



• CMR608

- Quality sound in style ...
- 5" enforced woofer, 1" tweeter
- 60 Watts program power @ 8Ω
- PAINTCM (option: any RAL colour)
- Dim. (outside): 237(h) x 170(w) x 65(d) mm
- Cutout : 210(h) x 143(w) mm

• CMR5

- The essentials
- 5" dual cone woofer
- 6 - 3 - 1.5 Watts 100 Volt transformer
- PAINTCM (option: any RAL colour)
- Dim. (outside): 237(h) x 170(w) x 65(d)
- Cutout : 210(h) x 143(w) mm

• CMR20T

- When sound meets design ...
- 5" enforced woofer, 1" tweeter
- 60 Watts program power @ 16Ω
- 20 - 10 - 5 - 2.5 Watts 100 Volt
- PAINTCM (option: any RAL colour)
- Dim. (outside): 237(h) x 170(w) x 65(d)
- Cutout : 210(h) x 143(w) mm

• CMRBB

- With the CMRBB on-wall back-box you can change a 5" CMR-build-in type into a cabinet speaker.
- PAINTCAB6 (option: any ral colour)
- Dim. 235(h) x 167(w) x 85(d)



• CMRBBI

- CMRBBI is used to build-in rectangular APart 5" CMR-Loudspeakers into concrete or brick walls.
- The build-in box has special grooves to guarantee an optimal grip into concrete and cement.
- Dim. 213(h) x 146(w) x 84(d)

* All dimensions are in mm

Cabinet

, APart offers you a full range of cabinet speakers to fit into any interior style or décor. Cabinet speakers that can be used independently or in a combination with our range of incredible compact and powerful subwoofers. Residential, retail, public buildings or catering,...

APart has a speaker to fit every budget and project !



Miniatures

without compromising on sound quality. MASK2 speakers in combination with a SUBLIME subwoofer offer a combination of cute looks and great sound. These incredibly small satellite speakers are designed especially for use in small to medium sized rooms in residential as well as public areas, while SUBLIME offers the ultimate blend of a compact size and deep, fat basses.

MASK2 SATELLITE SPEAKER



• MASK2-BL



• MASK2-W

- Sound quality that exceeds the market's standard
- Incredibly small design allows inconspicuous integration
- Easy mounting in corners or on ceilings with the included special bracket
- Full range 2.5" speaker, 50 Watts program power @ 8 Ohm
- Dimensions : 94 (h) x 82 (w) x 108 (d) mm

AMBI120 SET



- AMBI120-BL
- 1 x CONCEPT1
- 2 x MASK2-BL
- 1 X SUBLIME-BL

- AMBI120-W
- 1 x CONCEPT1
- 2 x MASK2-W
- 1 X SUBLIME-W

SUBLIME SUBWOOFER

- Extremely slim and compact, but yet produces a full, deep bass
- Built-in stereo X-over : the ideal partner for MASK2 satellite speakers
- Wall mounting brackets included
- 6.5" dual coil woofer
- 2 x 80 Watts @ 8 Ohm
- Dimensions : 420 (h) x 470 (w) x 120 (d) mm



• SUBLIME-W

• SUBLIME-BL



Champion

Thanks to their unique design, easy mounting and outstanding sound reproduction, MASK speakers have become one of the best selling APart products. They are available both in 8 Ohm and 16 Ohm/100 V, which makes them suitable for both low impedance as well as constant voltage installation. This series offers a combination of amazing sound and stunning looks: your guarantee for success in residential as well as commercial installations!

MASK4 INNOVATION



- MASK4T-BL 
- MASK4-BL



- MASK4T-W 
- MASK4-W



- MASK4T-SLV 
- MASK4-SLV

- MASK4-BL • MASK4-W • MASK4-SLV

- Cute as a baby
- 4.2" HD woofer, 1" tweeter
- 70 Watts program power @ 16 Ohm
- 20 - 10 - 5 - 2.5 Watts 100V transformer
- Protection Guard™ Technology
- PAINTCAB6 (option: any RAL colour)
- IP64 / Dimensions : 223 (h) x 129 (w) x 130 (d) mm

- MASK4-BL • MASK4-W • MASK4-SLV

- small and elegant
- fits into every décor and interior style
- 4.2" HD woofer, 1" tweeter
- 70 Watts program power @ 8 Ohm
- Protection Guard™ Technology
- PAINTCAB6 (option: any RAL colour)
- IP64 / Dimensions : 223 (h) x 129 (w) x 130 (d) mm

MASK6
REFERENCE



•MASK6-BL

•MASK6T-BL



•MASK6-W

•MASK6T-W



• MASK6-BL • MASK6-W

- The new reference ...
- 6.5" HD Woofer, 1" tweeter
- 200 Watts program power @ 8Ω
- Protectionguard™ technology
- PAINTCAB6 (option: can be painted in any RAL colour)
- IP64 / Dimensions: 315 (h) x 175 (w) x 195 (d) mm

• MASK6T-BL • MASK6T-W



- Quality & design 100V / 16Ω solution
- 6.5" HD Woofer, 1" tweeter
- 200 Watts program power @ 16Ω
- 60 - 30 - 15 - 6 Watts 100V transformer
- Protectionguard™ technology
- PAINTCAB6 (option: can be painted in any RAL colour)
- IP64 / Dimensions: 315 (h) x 175 (w) x 195 (d) mm

Involvement

of both end users and contractors alike formed the basis of the design for the INTELLI-MOUNT. The INTELLI-MOUNT is the perfect result of synergy between our years of experience and the wishes and remarks made by contractors in the field. This bracket comes as standard with all MASK4 & MASK4T, MASK6 & MASK6T models. A series of handy mounting accessories have been added to the range.

MASK1W - MASK1BL L-BRACKET



- MASKL-W
 - MASKL-BL
- (a set contains 1 pair)



MASKVW - MASKVBL V-BRACKET



- MASKV-W
- MASKV-BL

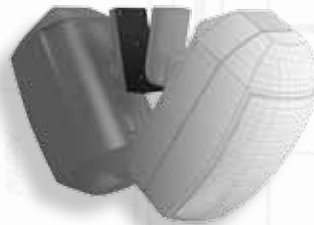

MASKWW - MASKWBL W-BRACKET



- MASKW-W
- MASKW-BL

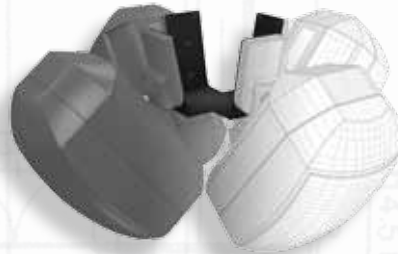

MASK4 & MASK6 SERIES INTELLI-MOUNT



- INTELLI-MOUNT
- (Included in MASK4 & MASK6 series)

MASK4 & MASK6 SERIES SAFETY



- SAF CAB6
- (Included in MASK4 & MASK6 series)



Flagship

Mask8 is the flagship of the MASK loudspeaker series.

Its sound quality and output level fits both background and high-level dance music.

Next to the MASK8 top speakers we now introduce the MASK8F : a full range speaker that can be used without subwoofer and that has a sound that comes close to a studio monitor. Whatever model you choose, you are always sure to experience every musical characteristic and any vocal detail of any musical style!

MASK8 PRECISION



- MASK8-BL*
- MASK8F-BL*



- MASK8-W
- MASK8F-W

• MASK8-BL • MASK8-W

- Vocal perfection and dynamic music
- Protection-Guard™ technology
- MDF Wooden cabinet
- 8"HD woofer, 1" tweeter
- 300 Watts program power @ 8 Ohm
- PAINTCAB8 (option: any RAL colour)
- Dimensions : 411(h) x 250 (w) x 250 (d) mm

• MASK8F-BL • MASK8F-W

- Full range speaker for stand-alone use without subwoofer
- HiFi quality at amazing high levels
- Protection-Guard™ technology
- 8"HD woofer, 1" tweeter
- 300 Watts program power @ 8 Ohm
- PAINTCAB8 (option: any RAL colour)
- Dimensions : 411(h) x 250 (w) x 250 (d) mm



- 90° rotatable 100°H x 70°V horn for vertical installation



- Mounting bracket included with all MASK8 models

Powerful yet so small is the most often heard comment about our passive subwoofers. The 10" dual coil, professional woofer produces an incredibly strong low bass that makes it easy for the satellites to complete the sound without fuss. The modest looking subwoofers occupy so little space they can be put under a bench, in a corner or they can be built into furniture.

**SUB2400
FOUNDATIONS**



• SUB2400*

• SUB2400-W

- SUB2400* • SUB2400-W
- David beats Goliath
- Very robust Plywood construction
- Stronger and "faster" than bigger 15" subs
- 2 pcs 10" dual coil long Xmax woofer
- 2 x 400 Watts program power
- 4Ω or 16Ω selector at back panel
- Protection-Guard™ technology
- Dimensions: 700 (h) x 352 (w) x 450 (d) mm

**SUB2201
SUBWOOFER**

- Smooth and punchy bass from a compact enclosure
- 10" long-stroke woofer
- 250 Watts music power @ 4 Ohm
- Ideal partner for APart MASK speakers in active setup, X-over frequencies at 150 Hz
- Now in plywood and with structured paint
- Dimensions : 600 (h) x 300 (w) x 380 (d) mm



• SUB2201-BL*

• SUB2201-W

**POLE
MOUNT**



- STFLOOR
- Floorstand for MASK8F-BL or MASK8-BL speaker



- STSUB
- Pole to combine the SUB2400 or SUB2201 with MASK8F-BL or MASK8-BL speaker



- STT
- T-mount to mount two MASK8F-BL or MASK8-BLspeakers on a single STSUB pole or STFLOOR stand.

* Our black cabinets are equipped with 35mm pole mount adaptor.

Vibrations

Can you believe your ears? Yes, you can! These small subwoofers are responsible for the deep bass that gives you this perfect sound! They are compact, and available in white and black color, a guarantee that they can be integrated in any interior: public or home. SUBA165 and SUBTILE fill the room with a full rich sound, even if you are using small top speakers.

SUBA165 COMPACT



• SUBA165

• SUBA165-W

- Compact, yet powerfull
- 8" HD type woofer
- Adjustable active x-over
- 140 Watts power amplifier, auto -on/off
- Line or speakerline inputs
- Passive stereo low-Cut x-over for top satellites
- Dimensions : 362 (h) x 261 (w) x 405 (d) mm

SUBTILE THIN

• SUBTILE-BL



• SUBTILE-W

- Brings incredible vibes in shops, lounge bars or in a living room
- 125 W @ 4 Ohm program power
- Wall bracket suspension system included
- Perfect match with Champ-4 amplifier
- Dimensions: 450 (H) x 500 (W) x 120 (D) mm

Probably the thinnest sub in the world... Custom-designed to be integrated inconspicuously into any interior, or to be hidden under a closet, behind a curtain or under a sofa.

Industry standard

: especially for classrooms, meeting rooms, boardrooms,... these active speaker sets combine clever features and reliability with unique affordability. The new SDQ5PIR offers IR and RS232 control along with remote and optional wall panel control.



•SDQ5P-BL

• SDQ5P-BL

• SDQ5PIR-W

•SDQ5P-W

SDQ5P ACTIVE



SDQ5PIR DIGITAL



- Comes as a stereo speaker set: 1 active and 1 passive LS
- Dynamic music and detailed voice clarity
- 2 x 30 Watts RMS power for high level outputs
- Balanced inputs allow long input-signal cables
- Bass & treble control
- RCA and mini-jack stereo inputs (MP3 players)
- Low distortion, high efficient 5.25" woofer and 1" tweeter
- Magnetically shielded components
- Brackets and 3 metres long power cord included
- Dimensions (L = R): 243 (h) x 180 (w) x 148 (d) mm

- Same ad above, now with IR and RS232 control
- Input A: unbalanced stereo mini jack connector
- Input B: balanced euroblock connectors
- 2 x 30 Watts music power
- Volume, bass + treble control, auto-off standby function
- IR remote control, mounting brackets and 3m power cord included
- Optional: wall panel remote control
- Dimensions (l=r) 243 (h) x 180 (w) x 148 (d) mm



Established Value

probably is the key feature of the SDQ series. With the price quality ratio becoming more and more important in the contractor market, the SDQ loudspeaker range perfectly matches this criterion!

Its new discrete, yet distinguished design is in perfect harmony with the transparent sound exhibited. The SDQ series are available for both constant voltage and- or low impedance use, all with overload protection and brackets included.

SDQ3 MINI



• SDQ3T-BL



• SDQ3T-W



• SDQ3T-SLV



- Small & Cute, but yet a great sound
- 3" woofer, 1" tweeter
- 40 Watts program power @ 16Ω
- 6 - 3 - 1,5 Watts 100V transformer
- PAINTCAB6 (option: can be painted in any ral colour)
- Dimensions: 152 (h) x 105 (w) x 110 (d) mm

SDQ5 SERIES



• SDQ5-BL

• SDQ5T-BL



• SDQ5-W

• SDQ5T-W



• SDQ5T-SLV

- SDQ5T-BL • SDQ5T-W • SDQ5T-SLV

- Reliable & competitive install solution
- 5.25" woofer, 1" tweeter
- 80 Watts program power @ 16Ω
- 30 - 15 - 6 - 3 Watts 100V transformer
- PAINTCAB6 (option: any ral colour)
- Dimensions: 245 (h) x 180 (w) x 154 (d) mm

SDQ3 & SDQ5 SERIES SAFCAB6



- available as an option

- SDQ5-BL • SDQ5-W

- Powerfull HiFi sound
- The winner takes it all!
- 5.25" woofer, 1" tweeter
- 80 Watts program power @ 8Ω
- PAINTCAB6
- Dimensions: 245 (h) x 180 (w) x 154 (d) mm

Engineered

thanks to the 8" woofer and 1" silk-dome tweeter, the SDQ8 provides you with HiFi quality sound for ambient background music applications. The well engineered woofer coupled with an optimised bass-reflex housing results in a high performance sound, not normally associated with a relatively small cabinet. The SDQ8 is available in black or white and comes with a sturdy U-bracket.

SDQ8
SERIES

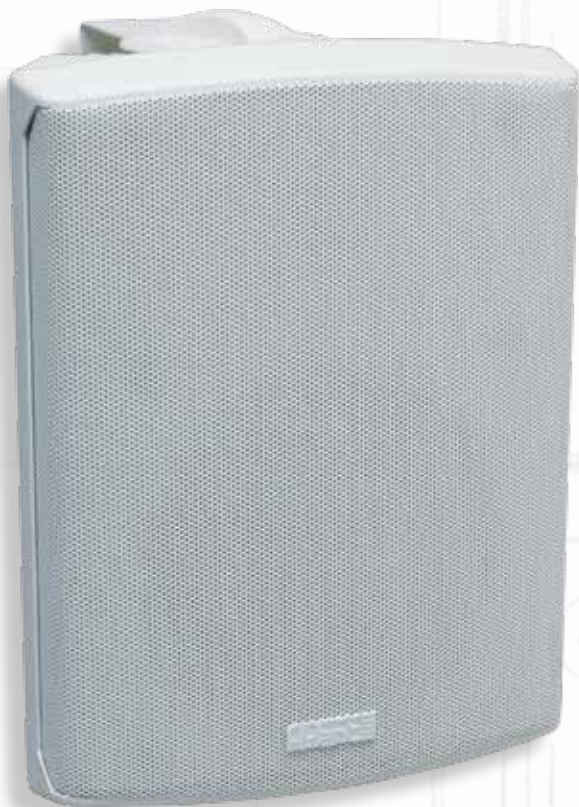

•SDQ8-W

•SDQ8T-W 

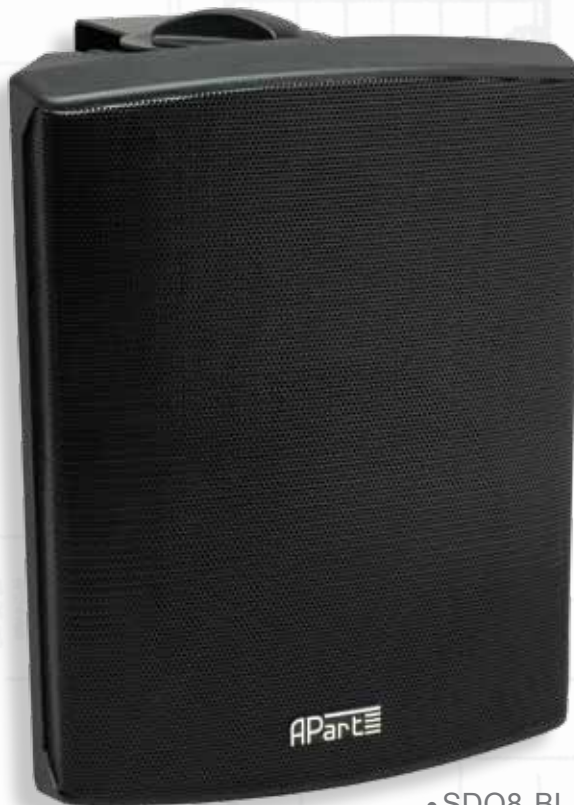

•SDQ8-BL

•SDQ8T-BL 

•SDQ8-BL •SDQ8-W

- Power at a price easy to live with!
- 8" woofer, 1" tweeter
- 160 Watts program power @ 8Ω
- PAINTCAB8 (option: any ral colour)
- Dimensions: 381 (h) x 283 (w) x 243 (d) mm

•SDQ8T-BL •SDQ8T-W 

- A powerfull contractor solution
- 8" woofer, 1" tweeter
- 160 Watts program power @ 16Ω
- 60 - 30 - 15 - 6 Watts 100V transformer
- PAINTCAB8 (option: any ral colour)
- Dimensions: 381 (h) x 283 (w) x 243 (d) mm

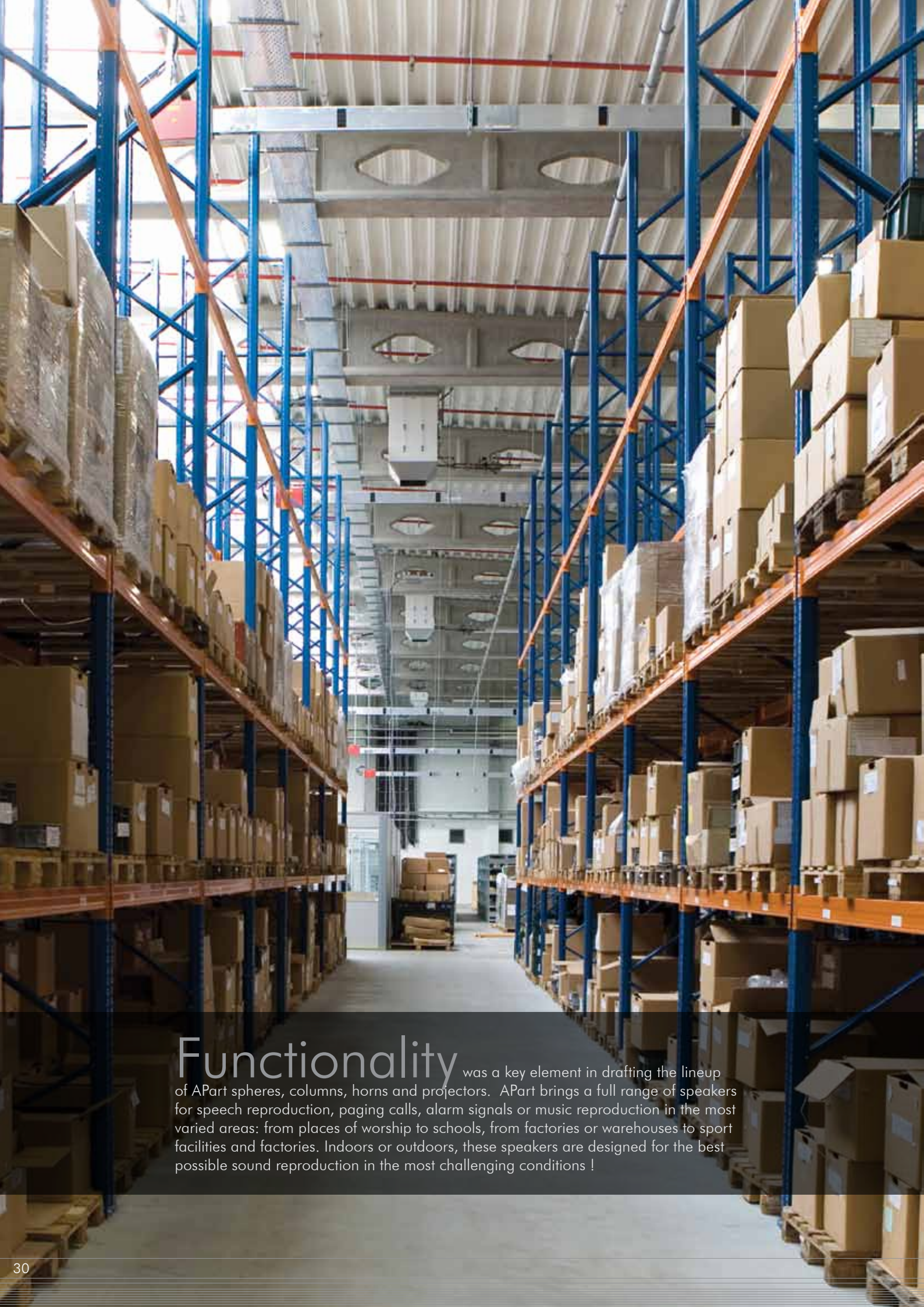

Functionality was a key element in drafting the lineup of APart spheres, columns, horns and projectors. APart brings a full range of speakers for speech reproduction, paging calls, alarm signals or music reproduction in the most varied areas: from places of worship to schools, from factories or warehouses to sport facilities and factories. Indoors or outdoors, these speakers are designed for the best possible sound reproduction in the most challenging conditions !

Inconspicuous

Part sphere loudspeakers are suspended in buildings that exceed 4 meter in height and with low environmental noise. Because of the equal and spherical sound dispersion, they can cover an expansive area with a minimum number of speakers.

The Rock series is designed to be hidden in the gardens of private homes, theme parks, pool areas...

Suspended high up in a building or hidden in shrubs: it's hard to tell where this amazing sound is coming from!

ROCK ESPECIALLY



• ROCK608

- Inconspicuous integration, amazing sound
- 6.5" woofer, 1" tweeter
- 60 Watts program power @ 8Ω
- PAINTCAB8 (option: any RAL colour)
- Dimensions: 260 (h) x 200 (w) x 280 (d) mm

• ROCK20

- The reference for large gardens
- Inconspicuous integration
- 6.5" woofer, 1" tweeter
- 20 - 10 - 5 - 2.5 Watts 100 Volt transformer
- PAINTCAB-8 (option: any RAL colour)
- Dimensions: 260 (h) x 200 (w) x 280 (d) mm

SPH16 SMOOTH



• SPH16

- Imperceptible design, great 2-way sound quality
- 5.25" woofer & 1" tweeter
- 16 - 8 - 4 Watts 100 Volt transformer
- 3 metres connection cable with metal safety wire
- PAINTCAB6 (option: any ral colour)
- Dimensions: 180 mm outside Ø

SPH20 DISPERSION



• SPH20

- Loud and wide sound dispersion ...
- 8" dual paper cone woofer
- 20 - 10 - 5 Watts 100 Volt transformer
- 3,3 metres connection cable with metal safety wire
- PAINTCAB8 (option: any ral colour)
- Dimensions: 254 mm outside Ø

STURDY

quality. This range of sound projectors is designed for high quality music and speech reproduction in many industrial or professional applications, both in- or outdoors. These speakers combine a rugged housing with good sound quality, and have either epoxy coated, aluminum or stainless steel mounting brackets. Your only guarantee for long-term outdoor use without rusting!



- **MP16-G** 
- Compact and stylish sound projector
- 5.5" coated paper dual cone woofer
- 16 - 10 - 5 Watts 100 Volt transformer
- IP56 + All metal parts aluminum or stainless steel: no rust
- PAINT MP (option: any RAL colour)
- Dimensions: 138 (diameter) x 200 (l) mm



- **MP26-G** 
- Powerful and stylish sound projector
- 6.5" coated paper dual cone woofer
- 26 - 20 - 10 Watts 100 Volt transformer
- IP56 + All metal parts aluminum or stainless steel: no rust
- PAINT MP (option: any RAL colour)
- Dimensions: 170 (diameter) x 240 (l) mm



- **MPH30-G** 
- Horn loaded sound projector
- 5.25" treated paper cone woofer
- 30 - 20 - 15 - 10 - 5 Watts 100 Volt or 8Ω
- IP54 + Epoxy coated bracket included : no rust
- PAINTMP (option : any RAL colour)
- Dimensions : 180 (diameter) x 200 (l) mm

Heavy Duty

These horns are loud! Especially for high output speech, alarm signal, or even music reproduction in the industry or outdoors.

Every horn has an in-house designed driver, and is equipped with a stainless steel or aluminum mounting bracket, to avoid rust. APart horn speakers are ready to do the job even in the most demanding of circumstances, indoors or outdoors.



- **H10-G** 
 - Compact compression horn loudspeaker
 - For high background noise use
 - Ideal for speech and alarm signals
 - Selector 10 - 5 - 2.5 - 1.25 W in 100 V or 8Ω
 - IP66 + Stainless steel bracket (no rust)
 - Diameter: 140 mm – Length: 192 mm

- **H20-G** 
 - Powerful compression horn loudspeaker
 - For high background noise use
 - Ideal for speech and alarm signals
 - Selector 20 - 10 - 5 - 2.5 W in 100 V or 8Ω
 - IP66 + Stainless steel bracket (no rust)
 - Diameter: 200 mm – Length: 232 mm

- **H30LT-G** 
 - Long throw compression horn loudspeaker
 - Wide dispersion, high efficiency
 - Ideal for speech and alarm signals
 - Selector 30 - 15 - 7.5 - 3.75 W in 100 V or 8Ω
 - IP66 + Stainless steel bracket (no rust)
 - Dimensions : 208 (h) x 285 (w) x 290 (d) mm

- **MPLT32-G** 
 - High quality 2-way long throw music projector
 - 6.5" cone woofer & 1" horn driver
 - 32 - 16 - 8 - 4 Watts 100 Volt transformer
 - IP66 + Aluminium bracket (no rust)
 - PAINTMPLT (option: any RAL colour)
 - Dimensions : 250 (h) x 360 (w) x 290 (d) mm

- **MPLT62-G** 
 - Very powerful 2-way long throw music projector
 - 6.5" cone woofer & 1" horn driver
 - 62 - 32 - 16 - 8 Watts 100 Volt transformer
 - IP66 + Aluminium bracket (no rust)
 - PAINTMPLT (option: any RAL colour)
 - Dimensions : 250 (h) x 360 (w) x 290 (d) mm

Elegant

APart's range of slim but powerful columns offers excellent audio directivity for music as well as speech. Thanks to the elegant design, these speakers are ideal for indoor and outdoor use: from sports fields to public buildings or recreational areas, meeting rooms or educational facilities. The high power COLW series, with both 100V and low impedance inputs, have an amazing high output level, combined with well controlled sound dispersion.

COLW COLUMNS

- COLW41 
 - 4 x 3.3" full range woofer + 1 x 1" tweeter
 - 40 - 30 - 15 Watts 100 V transformer
 - 60 Watts music power @ 16 Ohm
 - PAINTCOL (option: any RAL colour)
 - IP66 / Dimensions : 555 (h) x 100 (w) x 83 (d)

- COLW81 
 - 8 x 3.3" full range woofer + 1 x 1" tweeter
 - 80 - 40 - 30 Watts 100 V transformer
 - 120 Watts music power @ 8 Ohm
 - PAINTCOL (option: any RAL colour)
 - IP66 / Dimensions : 974 (h) x 100 (w) x 83 (d)

- COLW101 
 - 10 x 3.3" full range woofer + 1 x 1" tweeter
 - 100 - 60 - 40 Watts 100 V transformer
 - 140 Watts music power @ 8 Ohm
 - PAINTCOL (option: any RAL colour)
 - IP66 / Dimensions : 1010 (h) x 100 (w) x 83 (d)

• DID YOU KNOW

- Tall columns have a much wider and controlled dispersion than shorter models.
- Our larger models also cover a wider area than conventional speakers, so less speaker cabinets are needed to achieve the same sound pressure in a certain area.

• COLWBRA



bracket for COLW range



Standard bracket included

Graceful

Our range of extra slim columns is especially suitable for sound reproduction in acoustically difficult venues. Advanced technology guarantees optimized sound dispersion and improved speech intelligibility. This decreases microphone feedback in reverberant locations such as houses of worship, sport facilities, public buildings as well as conference facilities and auditoriums. A low-impedance input allows an easy connection to flat screens.

Timeless design combined with impeccable sound reproduction.

COLS COLUMNS

- COLS41 
 - 4 x 2" full range woofer + 1 x 1" tweeter
 - 20 - 10 - 5 Watts 100 V transformer
 - 30 Watts music power @ 8 Ohm
 - PAINTCOL (option: any RAL colour)
 - IP66 / Dimensions : 400 (h) x 66 (w) x 66 (d)

- COLS81 
 - 8 x 2" full range woofer + 1 x 1" tweeter
 - 30 - 15 - 6 Watts 100 V transformer
 - 40 Watts music power @ 16 Ohm
 - PAINTCOL (option: any RAL colour)
 - IP66 / Dimensions : 613 (h) x 66 (w) x 66 (d)

- COLS101 
 - 10 x 2" full range woofer + 1 x 1" tweeter
 - 40 - 20 - 10 Watts 100 V transformer
 - 60 Watts music power @ 8 Ohm
 - PAINTCOL (option: any RAL colour)
 - IP66 / Dimensions : 723 (h) x 66 (w) x 66 (d)

- COLS141 
 - 14 x 2" full range woofer + 1 x 1" tweeter
 - 60 - 30 - 20 Watts 100 V transformer
 - 80 Watts music power @ 8 Ohm
 - PAINTCOL (option: any RAL colour)
 - IP66 / Dimensions : 940 (h) x 66 (w) x 66 (d)

- COLSBRA



bracket for COLS range



Standard bracket included

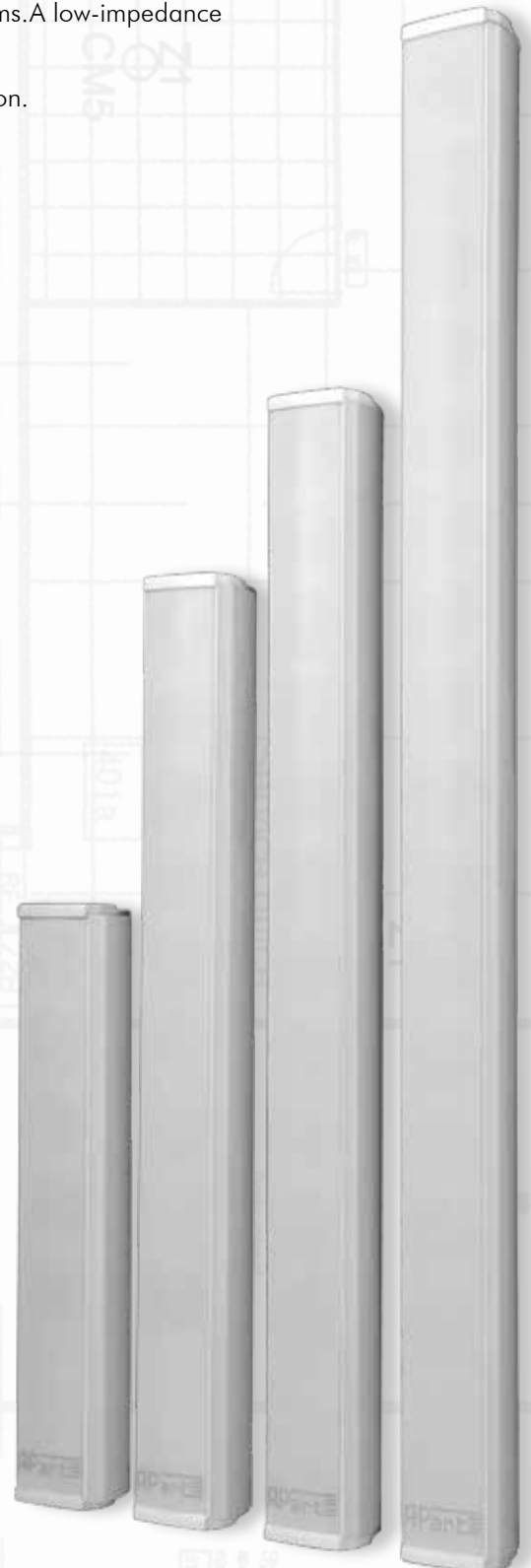

Reliable

APart brings a full range of pre-amplifiers, mixing amplifiers, low impedance and 100V power amplifiers. With the soundblock modular amplifier series, any installer is up to the challenge of building an extensive multi-zoning system. Next to an assortment of various sound sources, you'll also find an easy-to-use microphone system for both fixed installation and mobile use. Reliability and sound quality combined; the perfect match with our APart philosophy.





PRE-AMPLIFIERS

Page 38-42



SIGNAL PROCESSING

Page 43



POWER AMPLIFIERS

Page 44-49



INTEGRATED AMPLIFIERS

Page 48-49



MIXING AMPLIFIERS

Page 53-57



100V POWER AMPLIFIERS

Page 58-59



MUSIC SOURCES & SOUND SYSTEMS

Page 60-61



MICROPHONE SYSTEMS

Page 62-63



MODULAR AMPLIFIERS

Page 64-67

Multifunctional that's probably how colleagues will see the PM1122. Imagine a stereo pre-amplifier that can be used in a supermarket with 10 check-out lines, a church with 5 mics that need a noisegate, or even a professional 2 stereo zone wireless or RS232 controlled meeting room ? Your wish has now become reality : the PM1122 can handle every application and makes the use of a whole string of pre-amplifiers superfluous !

PM1122
STEREO PRE-AMPLIFIER

- High-grade electronics & engineering
- Nice LED's for a clear overview
- 4-Level priority system with emergency input
- Built in chime (volume adjustable)
- 230 V to 24V DC adaptor & 19" brackets included
- Dimensions : 44 (h) x 433 (w) x 222 (d)

INPUT
MICROPHONE SECTION

- 5 MIC/Line inputs with phantom power each
- Assignable to one or both stereo output zones
- Individual tone, gain and volume control per input
- Noise gate with adjustable threshold for Mic Mix
- Priority can be switched off per stereo output zone
- Mic input 5 can be link input to/from another PM1122



- 19" brackets included



- Metal cover for MIC inputs and Zone 2 output included



- NTM-1
- Optional balanced microphone transformer

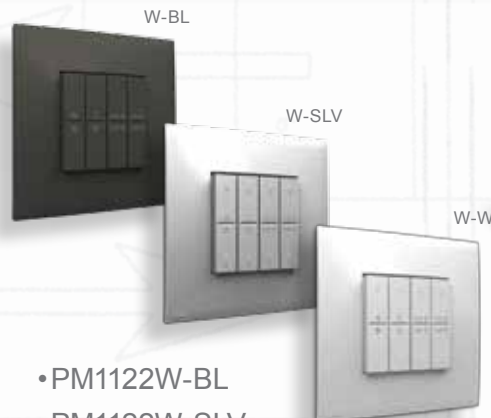

- PM1122W-BL
- PM1122W-SLV
- PM1122W-W
- Ultra flat wireless wall control can be fixed everywhere
- Source selection – Mic mix volume – music volume control
- Battery included, NO cables



• BB1



• BBi1



• BB2



• BBi2

• On and in-wall mounting boxes for the PM1122R & PM1122RL remote controls.

STEREO OUTPUTS 2-ZONE SECTION

- 4 stereo line inputs
- Line (music) selector per output zone
- Individual gain control per input at the rear side
- Music and Mic Mix level control by VCA
- Bass – treble tone control per output zone
- Multiple remote options available



• PM1122R ANALOG REMOTE CONTROL

- Very affordable
- Source select, Mic mix volume, Music volume

• PM1122RL ANALOG REMOTE WITH LOCAL AUDIO INPUT

- Same as PR1122R, but with additional;
- Balanced MIC & line input via stereo mini jack
 - Level control & Tone control for local input
 - Easy wiring via standard UTP CAT5 cable

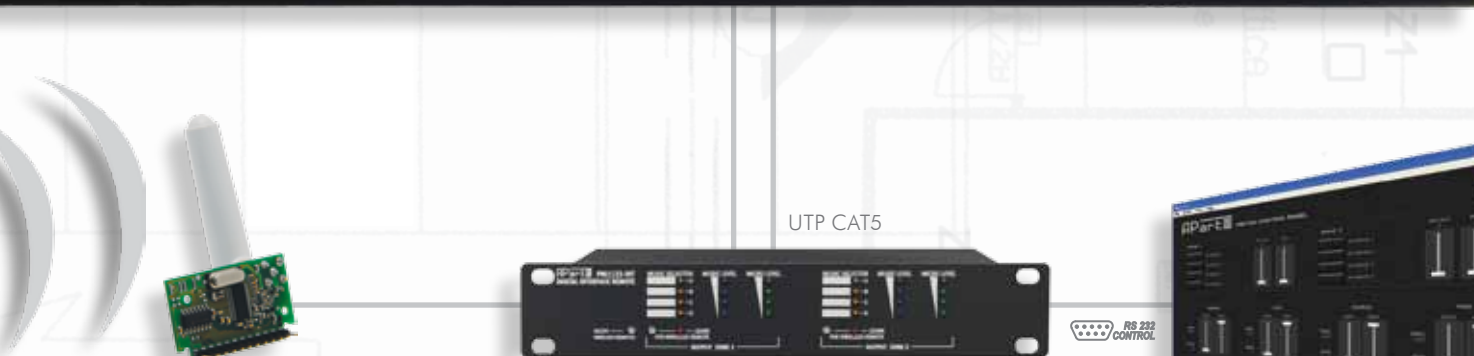

• PM1122WR

- Plug-in receiver module for RF wireless remote control panels
- Makes multiple remote controls possible per zone
- Optional with PM1122-INT

• PM1122-INT 2-ZONE DIGITAL REMOTE INTERFACE

- Connection with PM1122 via UTP CAT5 cable per zone
- SUB-D9 connector for RS232 control
- Up to 64 presets programmable and accessible via RS232
- 2 x 6 presets direct accessible via contact closure
- Clear LED status indication on front panel



- PC software included



More Zones

Following the overwhelming success of the 2-zone PM1122, APart now introduces a sophisticated pre-amplifier that allows you to control four stereo zones with just one affordable unit! ZONE4 allows the user to assign 3 microphones and 4 stereo line inputs to any of four output zones. A digital display, remote control, versatile, affordable: ZONE4 gives you the competitive edge to tackle even the most daunting challenges!

4 ZONE STEREO PRE-AMPLIFIER

- Perfect for multi-room and multi-zone
- Easy-to-use controls and display per zone
- Digital Control by RS-232, remote control panel, IR serial
- Priority input for paging or emergency
- Removable brackets included
- Dimensions : 44 (h) x 419 (w) x 184 (d)



INPUT MICROPHONE SECTION

- 3 mono MIC/LINE inputs via Euroblock connector
- Tone, gain and level controls available
- Every MIC input assignable to any of the 4 zones
- Phantom power selectable on MIC 2 and 3
- Paging : MIC1 mutes line input, MIC 2 + MIC 3 mix with line input
- Designed to work with MICPAT-4, four-zone paging microphone



MICPAT-4 PAGING MICROPHONE

- Designed to operate plug and play with ZONE4
- Selective paging and "page ALL"



ZONE4R REMOTE



- Basic controls : easy to use ! source select
- Status display
- Music level and mic-mix level control+mute, source select
- Sophisticated and yet affordable!
- Easy to wire with UTP CAT5

- On- and in-wall mounting box for the ZONE4R remote control



• BB1



• BB1i



RS 232
CONTROL



OUTPUT SECTION

- Line input selector per zone
- Bass - Treble control per zone
- Music level control per zone
- Independent mic-mix level control per zone
- Push to mute function for music and mic-mix per zone
- Mono or stereo configurable

RJ45SPLIT CONNECT

- RJ45 splitter : 1 in, 4 out
- to connect more MICPAT-4 or ZONE4R's



- 19" brackets included



- Metal cover for MIC settings included



Clear

You like things crystal clear, well organised, and above all easy-to-use. For all applications where standard pre-amplifiers lack possibilities, we step in and offer you clever solutions in both technical and non-technical ways.

PIR7600 PRE-AMPLIFIER



- Remote controlled stereo pre-amplifier mixer
- 6 Line, 2 mic inputs (MIC1: mic/line/tel. switch)
- 2 Stereo output zones
- IR or wired (RJ45) remote control
- Transfers IR signal of other devices
- Dimensions: 44 (h) x 483 (w) x 275 (d) mm



•PIR-REM
(Included)



•PIR-EMIT
(Included)



•PIR-REC
(Included)

PM7400MKII PRE-AMPLIFIER



- Versatile stereo Mic-Line pre-amplifier mixer
- 6 Line, 2 mic inputs (VOX mute on MIC 1)
- 2 stereo outputs
- Independant tone control for mic & line inputs
- Easy to use
- Dimensions: 44 (h) x 483 (w) x 275 (d) mm

POWER

SIGNAL OK

CH1

MAX

THE MAX INPUT LEVEL
CANNOT BE EXCEEDED

CH2

MAX

SIGNAL OK

AUDIOLOCK LEVEL CONTROLLER



- Automatic Level Controller: a pre-adjusted maximum SPL can not be exceeded
- Protects not only your loudspeakers but also your license
- No more broken woofers and tweeters
- Connected between the output of the mixer/pre-amplifier and the input of the power amplifier
- Unit can be sealed with included numbered seals

LOCK-KEY REMOTE

- Remote control unit for level adjustment of the AUDIOLOCK
- The manager is always in control; not the DJ
- With A/B level switch
- In a metal housing with key-lock



PXQ2215 EQUALIZER / X-OVER



- Professional stereo equalizer / X-over
- Equalizer : 2 x 15 bands, 2/3 octave
- Bypass & 6/12dB switch for L & R on frontpanel
- X-over: 20 - 300 Hz adjustable
- 24dB / octave Linkwitz Riley
- Dimensions: 44 (h) x 483 (w) x 280 (d) mm

Silent Revolution

Champ One realises what many in the audio industry deemed impossible: an amplifier without cooling fans that is capable of delivering pleasing musical sound quality, high dynamics and high reliability. Finally a high-end power solution for the installers market at an affordable price !

CHAMP-ONE POWER AMPLIFIER



WHY AUDIOPHILE

- Created by our high-end audio engineering team
- Realised by our professional-audio engineering team
- Approved by our customers' listening teams
- Pure, open, pleasing sound quality
- High power, incredible dynamic punch
- Very loud sounding ... without sounding hard
- It loves music! - No clipping allowed...
- 'tube' emulation for exceptional warm sound
- Full analogue design, but close to class-D efficiency

CHAMP-ONE SLV SILVER





PERFORMANCE CHARACTERISTICS

- Headroom power 2x400W – 2x600W (8 - 4 Ohm / Ch.)
- Dynamic power capacity ; 750 Watts/Ch. , > 20 Ampere
- Sine wave power(*) 2x300W – 2x450W (8 - 4 Ohm / Ch.)
- 46.000 uF high grade electrolytic capacitors
- Compact and high power toroidal transformer
- Genuine Neutrik speakon connectors
- Speaker wire binding posts
- Doubled RCA - XLR Neutrik input connectors
- Net dimensions and weight : 483 (w) x 88 (h) x 380 (d)mm, 13 kg
- (*) Sine wave is like a siren, it is not an audiophile music experience

INSTALLER BENEFITS

SILENT – FREE AIR COOLING – NO FAN

- Electronics stay dustfree
- No ventilator noise
- No maintenance or cleaning
- 24h/24h hour operation

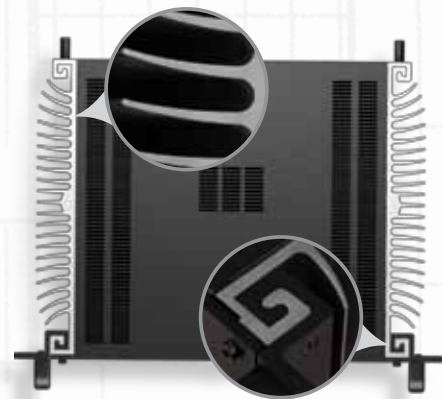

- Most efficient APart heatsink design
- Temperature and power monitored by APC
- One big PCB, so no internal cables and connectors
- Light weight, self-supporting aluminium chassis
- Strong and detachable 19" bracket system

INSTALLER BENEFITS

APC – AUTOMATIC POWER CONTROL



- Keeps music musical, no harsh or overload sound
- Keeps your speakers and the users out of trouble
- Preset of max program power (150 – 600W/ch)
- One model can fulfill all your applications
- Settings can be covered and secured

Family

affair: built on the same unique platform as its bigger sibling, CHAMP-2 offers equally peerless characteristics. This amplifier has no fans, and relies entirely on convectional cooling only. It's affordable, and it brings installers a dynamic, powerful sound that is unrivalled in its category!

CHAMP-2 STEREO AMPLIFIER



- High power, dynamic punch
- Unequaled pure music quality
- Loud, without sounding hard
- No clipping, no distortion : APC keeps control
- Can drive 3 pcs of 8 Ohm speakers in parallel per channel
- Individual level control on front

INSTALLER BENEFITS

- No ventilator, no noise, no dust problem
- No maintenance or cleanout procedure needed
- unique self-supporting aluminum chassis
- strong detachable 19" brackets

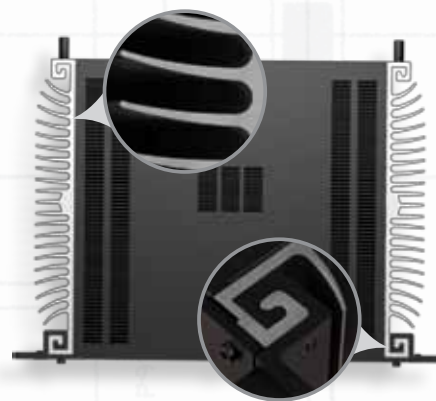

PERFORMANCE CHARACTERISTICS

- Headroom power 2x200 W (8 Ohm), 2 x 350 W (4 Ohm), 2 x 450 W (2.7 Ohm)
- Dynamic power capacity : 600 W/ch
- Sine Wave power(*): 2 x 120 W (8 Ohm) / 2 x 180 W (4 Ohm) / 2 x 200 W (2.7 Ohm)
- Heavy duty power supply
- Doubled RCA-XLR input connectors, speaker wire binding posts
- Net dimensions : 48.3 x 4.4 x 36 mm

(*) Sine wave is like a siren, it is not an audiophile music experience

Flexible

Solution, CHAMP-4 has the same unique features as the bigger models in APart's range of convection cooled amplifiers. The bridging possibilities and the built-in X-over in this 4-channel amplifier allow you to create many superior sound systems.

CHAMP-4 QUAD AMPLIFIER



- Flexible 4 channel amplifier
- For small and medium sized areas
- Pure musical sound
- APC avoids clipping and distortion
- Individual level control on front
- Built in X-over

INSTALLER BENEFITS

- Use 2 channels as subwoofer channels and drive the top speakers with the 2 remaining channels. The built in X-over guarantees a superior sound result.
- No ventilator, no noise, no dust problem
- No maintenance or cleanout procedure needed
- unique self-supporting aluminum chassis
- strong detachable 19" brackets

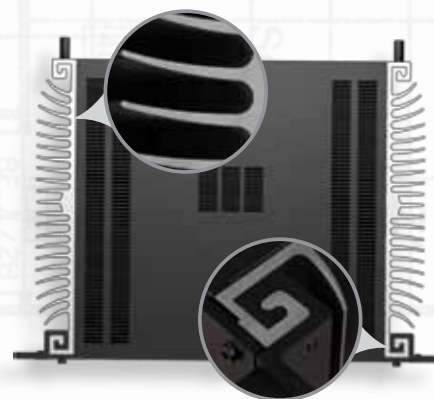

PERFORMANCE CHARACTERISTICS

- Headroom power: 4 x 75 Watts (8 Ohm), 4 x 125 Watts (4 Ohm)
- Sine wave power(*): 4 x 60 Watts (8 Ohm), 4 x 80 Watts (4 Ohm)
- High power, high reliability toroidal transformer
- Low impedance power supply for improved dynamic response
- Net dimensions 48.3 x 4.4 x 36 mm (WxHxD)

Two of a kind

The PA8250 is a compact but versatile 8-zone power amp that provides 8 x 250 Watts or 4 x 500 Watts in bridged mode. The inputs and speaker terminals can be connected with a Euroblock connector, so soldering in difficult on-site conditions is no longer a nightmare. The combination with the PT8210 – an 8-channel 100 V transformer with built-in monitor panel – provides a maximum of flexibility to build a custom-designed system of 100V and low impedance zones.

PA8250 8-CHANNEL



- 8-channel power amplifier
- 8 x 150 Watts in 8 ohm, 8 x 250 Watts in 4 Ohm
- Per 2 channels bridgeable: 4 x 500 Watts in 8 Ohm bridged
- Clever Input signal routing by switches on rear panel
- 75Hz Low-cut Filter (defeatable)
- Mono – stereo switches
- Dimensions : 132 (h) x 483 (w) x 484 (d) mm

PT8120 MONITOR & TRANSFORMER



- 8 Toroidal 50 - 70 - 100V transformers of 120 Watts
- 8 x 120 Watts or 4 x 240 Watts possible
- With integrated loudspeaker + VU LED's for 8-channel monitoring
- Channel selection at front panel via push button
- Ideal in combination with the PA8250 power amplifier
- Dimensions : 82 (h) x 483 (w) x 350 (d) mm

Wolf in sheep's clothing! The PUBDRIVE-2000 is a complete power amplifier with a signal processing unit. It is therefore no longer necessary to patch multiple electronics. The PUBDRIVE-2000 does it all! Its design is based on uncompromised high quality components. Huge power is always available, no matter what loudspeakers are being driven. The complete protection and limiting circuits inside make the PUBDRIVE-2000 a fail-safe amplifier suitable for 24-hour operation.

**PUBDRIVE-2000
HUGE POWER**



- 3 channel power amplifier
- Adjustable X-over for L & R top channel (70-120 Hz)
- Pre-amp out / Amp-in for external processors or links
- Build in extended AP® limiter
- SUB channel: 1200 Watts RMS @ 2Ω
- L & R top channel: 2 X 440 Watts @ 2.7Ω
- Dimensions: 134 (h) x 483 (w) x 482 (d) mm

**FIGHTPACK
FLEXIBLE**

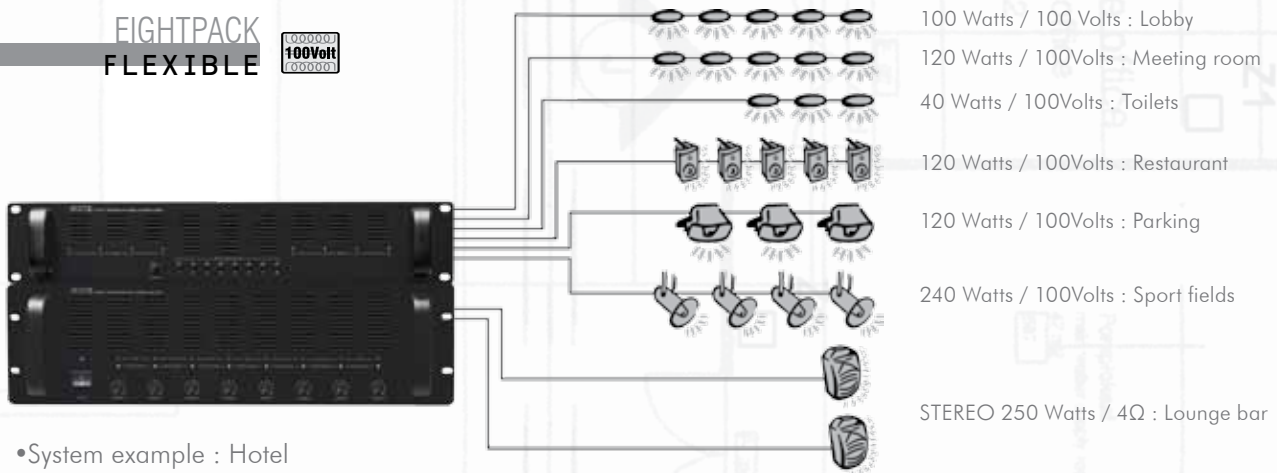

• System example : Hotel

Combination The PA8250 and the PT8210 form a compact but versatile combination of power amp and 100 V transformer. It offers a maximum of flexibility to build a custom-designed system with 100 V and low impedance zones and it allows the installer to monitor each zone from the central rack location.



Tailor made for small businesses: Concept1 bridges the gap between consumer hifi and pro-audio. Affordable, reliable, and loaded with professional features - available at the touch of a button!.

CONCEPT1

THE PROFESSIONAL SOLUTION

- 4 stereo line inputs
- 1 Mic input - can be mixed with line inputs
- Separate user and expert settings
- Control via RS-232 or optional IR
- Reliable 24/7 : extended limiters inside
- Dimensions : 430 (w) x 88 (h) x 320(d)



CONCEPT1

2X4Ω AMPLIFIER

- 2-zone integrated stereo mixing amplifier
- 2 x 80 Watts @ 4 Ohm

CONCEPT1T

100V AMPLIFIER



- 2-Zone 100V integrated mixing amplifier
- 2 x 60 Watts in 100 V

SETTINGS

USER

- SIMPLE and EASY
- Music Volume Control
- Mic level control
- Bass-Treble tone control

EXPERT

- ADVANCED and SECURED
- Zone mode settings
 - 1 stereo zone
 - 2 volume linked mono zones
 - 2 individual mono zones
- Maximum music & Mic volume
- Gain input adjustment
- Automatic loudness on/off
- Paging on/off per zone



- Removable rack ears included

AParTE

1 UNIT 3 OPERATING MODES

Concept1 gives you the choice between 1 stereo zone, 2 individual zones or 2 individual volume-linked zones*, at the touch of a button!

*In a volume-linked zone system, the volume of both zones goes up or down simultaneously at the turn of the volume button, while maintaining the proportional volume difference between the two zones.



RS 232 CONTROL

CONCEPT1 OPTIONS

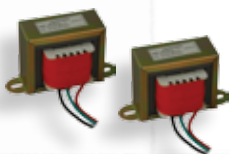

- CONCEPT1T-KIT : transfers a Concept1 into a 100V CONCEPT1T



- MICPAT-2 : 2 Zone dynamic paging microphone (see p 70)



- CONCEPT1-RC : Infrared remote control

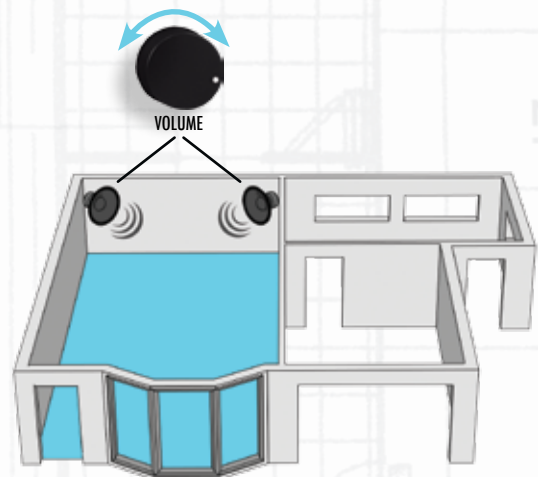

- 1 STEREO zone

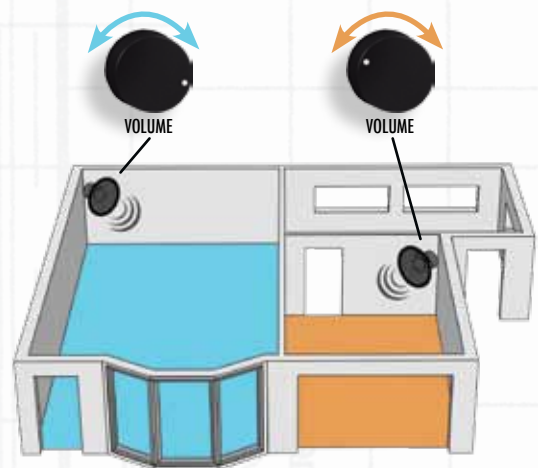

- 2 individual zones

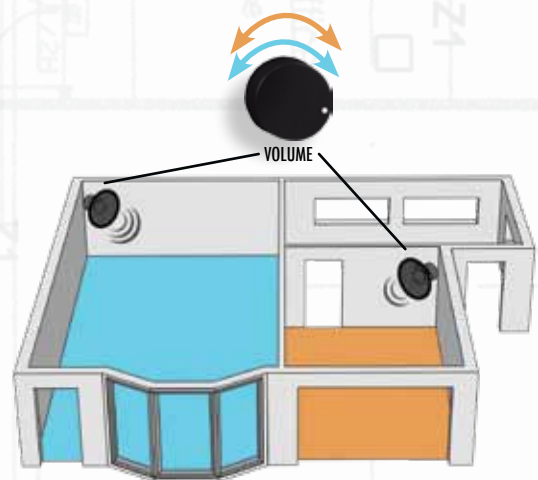

- 2 individual volume linked zones

Quality

Audio Solutions from Belgium: APart's mixing- and 100 Volt power amplifiers are the very heart of fixed audio installations all over the world. We have our roots and experience in the Belgian installer community, and our products are the result of personal contact and close collaboration with installers and a worldwide distributor network. A partnership that allows every installer to handle even the most challenging of projects!



Mixing

amplifiers are the heart of many small- and medium sized installation projects. APart brings an exhaustive range with essential and user-friendly features combined into compact units. Whether it is stereo, 100V technology or low-impedance, this series offers the complete and cost-effective solution every installer is looking for!

MA35
COMPACT



- Compact 35 Watts 100 Volt mixing amplifier
- 3 mic (phantom via internal switch), 2 line inputs
- 2 level priority system (VOX & contact closure)
- Integrated 2-tone chime (adjustable volume)
- Operates with 12V DC or 230V AC
- Build-in dynamic limiter (-3 dB)
- Dimensions: 88 (h) x 272 (w) x 286 (d) mm

MA65
COMPLETE



- Same features as MA35
- Compact 65 Watts 100 Volt mixing amplifier
- Operates with 24V DC or 230V AC
- Dimensions: 88 (h) x 272 (w) x 286 (d) mm

MA35-19
BRACKET



- Metal 19" 2U mounting bracket for the MA35 and MA65 amplifier

MA125
POWER



- High quality 125 Watts 100 Volt mixing amplifier
- 4 mic (phantom via switch at the back), 4 line inputs
- 3 level priority system, 24V priority output
- Integrated 2-tone chime (adjustable volume)
- Build-in dynamic limiter (-3dB)
- Dimensions: 88 (h) x 430 (w) x 240 (d) mm

All in one

With the MA200 series, APart has created a range of extremely versatile and complete units. A series of 200 Watts mixing amplifiers with 4-zone selection, available with an AM/FM tuner or with CD/MP3 player and tuner combined. This line up has all the features - ready for use in almost every project!

MA200CDR ALL IN ONE



- High quality 200 Watts 100 Volt mixing amplifier
- Integrated AM/FM tuner and CD/MP3 player
- 4 mic (phantom via internal switch), 4 line inputs
- 3 level priority system, 24V priority output
- Integrated 2-tone chime (adjustable volume)
- 4 output zones (Zone 4: Mic / music selection)
- Build-in dynamic limiter (-3 dB)
- Dimensions: 88 (h) x 430 (w) x 375 (d) mm

MA200R RECEIVER



- Same as above, with AM/FM tuner only

MA200 BASICS



- Same as above, without any music source



Worldwide Are you planning a family holiday to a Mediterranean resort this year? Shopping at a local fashion megastore, working out in a fitness club or moving through your local airport on the way to a business meeting? Installers from across the world use APart speakers and electronics in the most challenging projects. Check out these and other case studies on the realizations pages of our website www.apart-audio.com.

Zoning

the MA246 brings a new dimension to using a 100 V PA mixing amplifier. This 240 watts 6-zone unit can be used stand-alone, or as the core of an expandable sound system. Because it offers independent source selection and volume control for zones 1 and 2-6, you can use it as a full multizoning system. The first in its kind; combined with an external paging amplifier, you can obtain an affordable selective paging system without any compromise.

MA246 INPUTS

- 4 line, sources
- Zone paging mic/line
- 3 line/mic-phantom
- Emergency/telephone
- Chime with level control
- 6 priority levels possible
- Tone control per input
- External paging amplifier input



MA246MR

TUNER & MEDIA PLAYER



- 6-zone PA mixing amplifier
- Integrated digital FM/AM tuner - 10 presets
- Media Player, plays MP3, WMA, CD
- USB memory stick slot & SD/MMC cards

MA246R

TUNER



- 6-zone PA mixing amplifier
- Integrated digital tuner - 10 presets

MA246

AMPLIFIER



- 6-zone 100 Volts PA mixing amplifier
- Removable rack ears included





MA246 OUTPUTS

Zone 1

- Selective paging possible
- Independent zone for use with external amp
- Individual source selection and volume control

Zone 2 - 6

- 240 watts internal amplifier
- Can have a different line source than zone 1 amplified zone
- Individual volume control per zone
- Zone 2-3-4 : 100 V
- Zones 5 & 6 : 70 V for 'silent areas'



MICPAT-6 MICROPHONE



- Selective 6-zone paging microphone.
- Connect Up to 5 pcs MICPAT-6 on 1 MA246
- RJ45 connector for zone selection, EUROBLOCK for mic signal.

MICPAT-2 MICROPHONE



- With use of MICPAT2, MA246 allows you to merge zones into 2 major paging groups.

COMPACT 480 WATTS 6-ZONE SYSTEM

- Selective paging with selective music interruption.
- Radio "GAGA" in the warehouse, radio "SERIOUS" elsewhere.

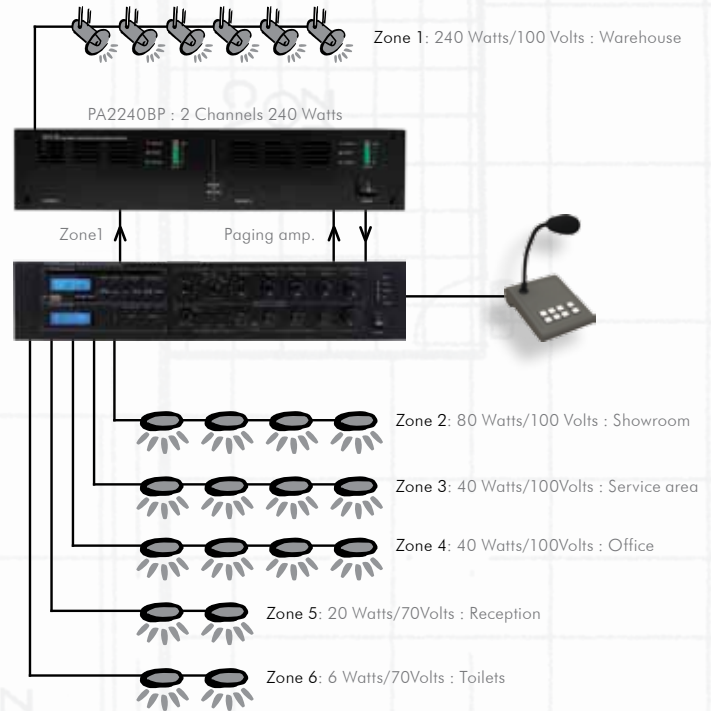

POWERFUL 720 WATTS 2-ZONE SYSTEM

- Selective paging in 2 assignable paging groups.
- Total control : 2 major zones, one with 5-sub zones.

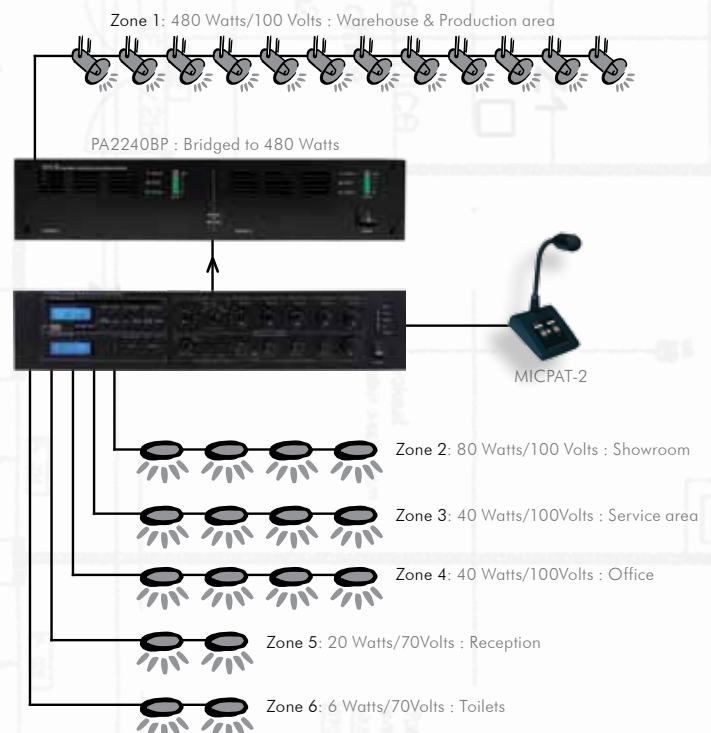

Endurance

In addition to the mixing and pre-amplifier series, the APart engineering team came up with fully equipped constant voltage power amplifiers that will meet all of your requirements. Besides high reliability and the basic functions of a power amplifier the PA240P excels above similar products by the inclusion of its extra technical features, possibilities and protection. In brief, it's the model you can rely on!

PA240P
ENDURANCE 



- Metal cover to avoid unauthorized volume and tone control adjustment of the amplifier



- Ultra reliable 240 Watts 100 Volt power amplifier
- Line input & adjustable priority line input
- 24V priority output
- Operates with 24V DC or 230V AC
- Bass – treble tone control
- Dimensions: 88 (h) x 433 (w) x 360 (d) mm



Finally an ultra-reliable and versatile 100V power amplifier is introduced to complete the APart 100V mixing amplifier and power amplifier series. The PA2240BP is fully equipped and can be used as a single (bridge mode) channel 480 Watts or dual channel 2 x 240 Watts power amplifier.

Its multi-functional use together with the technical features available will make the PA2240BP your favorite constant voltage power amplifier!

PA2240BP
1 OR 2-CHANNEL 



- 2-channel 100 Volt power amplifier
- 2 x 240 Watts, bridgeable into 1 x 480 Watts 70-100V
- Extra priority input per channel
- Volume and tone control per channel
- 24V output power available when priority is activated
- Operates with 230V AC or 24V DC
- Detachable 19" brackets included



- 2-channel 100 Volt power amplifier
- 2 x 240 Watts, bridgeable into 1 x 480 Watts 70-100V
- Extra priority input per channel
- Volume and tone control per channel
- 24V output power available when priority is activated
- Operates with 230V AC or 24V DC
- Detachable 19" brackets included

◀◀ FOLDER SELECT ▶▶▶▶ ▶▶▶▶ REV TRACK FFW▶▶▶▶ STOP PLAY/PAUSE EJECT



PROGRAM ASP SELECT MENU MUTE PLAY MODE USB CD

Two units

one goal : PCR3000R is a DAB+/FM-RDS tuner, CD-player and memory card media player, PC1000R is a CD-player and media player only. APart brings the tuner/media player that will finally allow you to ban cheap consumer Hi-Fi from your projects!

PCR3000R TUNER & MEDIA PLAYER



RS 232 CONTROL



• 19" brackets included

- DAB - RDS FM tuner + CD player + MP3 from CD, SD-card or USB memory stick
- New technology guarantees perfect radio reception, both with DAB and FM
- RS232 and IR remote control (included)
- Combined and individual output with gain control for tuner and CD/MP3 section
- Coaxial and optical digital audio output for CD section
- Dimensions : 44 (h) x 483 (w) x 280 (d) mm



PC1000R MEDIA PLAYER



RS 232 CONTROL



• 19" brackets included

- CD player and MP3 from CD, SD-card or USB memory stick
- RS232 and IR remote control (included)
- Coaxial and optical digital audio output
- XLR balanced and RCA audio outputs
- Double USB and SD slots (front and back)
- Dimensions : 44 (h) x 483 (w) x 280 (d) mm



PCD-REM REMOTE CONTROL

- Optional IR remote control enables DVD functionality on PCR3000R and PC1000R
- Dimensions: 196 (h) x 48 (w) x 14 (d) mm





Proficiency

APart's all new PR1000R and PR4000R mark a new era in tuner functionality! Highly recommended for use with Concept1, they are loaded with all the professional features. They are designed for 24/7 reliability. And best of all: they'll convince your customers to finally choose a professional system and avoid cheap, unreliable hifi consumer sets!

PR1000R RDS TUNER



• 19" brackets included



IR handheld remote control

- Professional 19" AM/FM RDS tuner
- RS232 and infrared control
- RDS information available on RS232 interface
- Galvanically separated antenna to avoid hum
- Comes with IR handheld remote and FM antenna
- Output attenuator on rear panel
- Dimensions: 44(h) x 483 (w) x 280 (d) mm

PR4000R QUAD RDS TUNER



• 19" brackets included



IR handheld remote control

- Four independent FM-RDS tuners in one 19" unit
- RS232 and infrared control
- RDS information available on RS232 interface
- Improved reception by DSP-technology
- Comes with IR handheld remote and FM antenna
- 4 output attenuators on rear panel
- Dimensions: 44(h) x 483 (w) x 280 (d) mm

Both the PR1000R and PR4000R now have RDS data available via the RS232 serial port. A huge added value for your (residential) projects!



Microphone system. Not all rooms have optimal acoustics and we aren't all blessed with clear dynamic voices. Also, meeting attendees aren't always skilled enough to operate complex mixing desks. To overcome these deficiencies the PA-CONF was developed as a simple and easy to use discussion system that can be used for meetings, presentations, discussions, conferences, ...

PA-CONF MICROPHONE SYSTEM



(Included)

• PA-CONF

- IR controlled microphone pre-amplifier
- CONF daisy chain jack input now on the front and back panel
- RCA insert on CONF input for external signal processors
- Inputs : conference, mic/line, line
- Up to 25 microphone terminals via daisy chaining, compatible to PACONF-S
- Dimensions : 44 (h) x 483 (w) x 280 (d) mm



Fig. 1

• PA-CONF C

- Design & solid table type or flush mount chairman microphone terminal
- Equipped with "SPEECH" and "PRIORITY" button
- Hi-Quality 470 mm uni-directional cardioid mic with LED ring included
- With build-in limiter. 12 m stereo jack cable included
- Dim. PA-CONF C : 40 (h) x 120 (w) x 154 (d) mm (Fig. 1)

• PA-CONF D • PA-CONF DI

- Design & solid table type or flush mount delegate microphone terminal
- Equipped with "SPEECH" button
- Hi-Quality 470 mm uni-directional cardioid mic with LED ring included
- With build-in limiter. 2 m stereo jack cable included
- Dim. PACONF D : 40 (h) x 120 (w) x 154 (d) mm (Fig. 3)
- Dim. PAFONF DI : 62(l) x 142 (w) x 125 (d) mm (Fig. 4)



Fig. 3



Fig. 4



Set PACONF-SET is an all in one microphone system solution. The set consists of 7 delegate microphones, 1 chairman microphone and all cables. All microphones and cables are packed in a robust flight case. This makes the PACONF-SET very suitable for presentations, mobile or occasional use in hotels, meeting rooms, rental services and many others.



• PACONF-SET

- Needs to be powered by a PA-CONF microphone system (not included)
- Dimensions flight case: 170 (h) x 560 (w) x 290 (d) mm

Modular

In some situations, different kinds of music are required to be at different levels at various locations ; thanks to the SOUNDBLOCK amplifier series it is possible to meet these demands with an easy to use and transparent sound system design. The SOUNDBLOCK amplifiers can be used as a stand-alone or modular amplifier. This allows you to create the exact configuration you need! The dynamic and high quality sound reproduction, together with the proven reliability, are just a few of the strengths embodied in the SOUNDBLOCK series.

MB150 POWER

- Compact modular mono amplifier
- RMS power : 150 Watts @ 4 Ω , 170 Watts @ 2 Ω
- 100 Hz low cut and 0/180° phase switch
- With build-in limiters & extended protection circuit
- Dimensions: 140 (h) x 70 (w) x 335 (d) mm



SB160 STEREO

- Compact stereo modular amplifier
- RMS power : 2 x 80 Watts @ 4 Ω
- 100 Hz low cut and mono/stereo switch
- With build-in limiters & extended protection circuit
- Dimensions: 140 (h) x 70 (w) x 335 (d) mm



Integration

External control is an essential factor in the modern sound system design. The MBR150 and SBR160 offer you a range of control possibilities by wired remote. This opens up a world of possibilities, even beyond the APart product range ...

MBR150 POWER

- Same as MB150, with some extra features :
- Bass - treble tone control
- Remote-power-on system via audio signal, 5-24V signal or on/off switch
- Remote volume control via up - down contact
- Dimensions: 140 (h) x 70 (w) x 335 (d) mm



SBR160 STEREO

- Same as SB160, with some extra features :
- Bass - treble tone control, balance
- Remote-power-on system via audio signal, 5-24V signal or on/off switch
- Remote volume control via up - down contact
- Dimensions: 140 (h) x 70 (w) x 335 (d) mm



PAM7.2
PRE-AMP

- Modular stereo pre-amplifier - mixer
- 5 line, 2 mic inputs (phantom via internal switch)
- 2 level priority (VOX: Mic 1 / contact: Mic 1-2)
- Dimensions: 140 (h) x 70 (w) x 335 (d) mm



MEQ5.2
EQUALIZER

- Modular 2 x 5 band equalizer
- Adjustable low cut (20 - 300 Hz) & volume per channel
- Balanced (XLR) & unbalanced (phono cinch) inputs & outputs
- Dimensions: 140 (h) x 70 (w) x 335 (d) mm



DT-150
TRANSFORMER



- Dual channel 4Q to 100/70/50 Volt transformer
- 2 x 150 Watts or 2 x 80 Watts (via switch)
- 2 x Hi-Q toroidal transformers build-in
- Suitable for MB(R)150 and SB(R)160
- Dimensions: 140 (h) x 70 (w) x 335 (d) mm



QUADPACK MULTICHANNEL

1000W
100VOLT
CLASS D



- Reliable 100V Multi channel amplifier
- RMS power: 4 x 150 Watts in 100V
- 100Hz low cut and 0/180° phase switch per channel
- Each channel with build-in limiter & extended protection circuit
- Comes with short AC power link cables
- Dimensions: 176 (h) x 483 (w) x 360 (d) mm

SIXPACK MATRIX



- Reliable and powerful multi channel power amplifier
- RMS power: 12 x 80 Watts in 4 Ohm
- Remote volume control via up-down contact
- Bass – treble tone control and balance
- Comes with short AC power link cables
- Dimensions: 176 (h) x 483 (w) x 360 (d) mm

MB19 HOUSING



- Sturdy metal 19" housing for 1 to 6 modules
- Dimensions: 176 (h) x 483 (w) x 340 (d) mm

MBBI PANELS

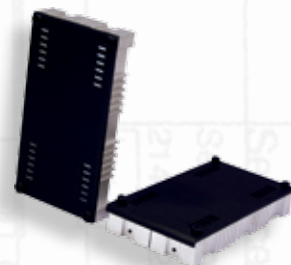

- Set of front and rear blanking panels for MB19
- Dimensions: 2 x 140 (h) x 70 (w) x 21 (d) mm

MBAC & SLAC CABLE



- MBAC
- Short 230V AC power-link cable
- Length: 350 mm



- SLAC
- Short 230V AC power cord
- Length: 650 mm



Instant recognition A comprehensive assortment of volume controls and accessories completes the APart product range. These items are designed and selected to fit in seamlessly with our main product range.



VOLUME CONTROL

Page 70-71



PAGING MICROPHONES

Page 72

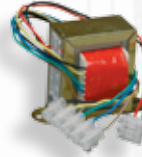

ACCESSORIES

Page 73



INSTALLER TOOLS

Page 73



CABLES

Page 73

ACCESSORIES VOLUME CONTROL

Complete

is the range of euro volume controls. Their inconspicuous design allows a perfect integration with your light switches and power plugs. Being available in a constant voltage and a low impedance version ensures a solution in almost every application. Different cover plates are available in order to match the UK standard. If you need more remote control for more functions, then you can reconsider your system design with the PM1122 (page38) ZONE4 (page40).

CONTROL EURO SERIES

MOUNTING IN- / ON-WALL



Fig1



Fig2

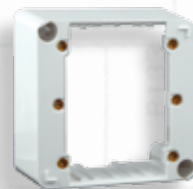

•E-MODON



•E-MODIN

MODEL	100Volt 	Stereo	24V Priority	Inverted Priority feature	Power	Steps	H (mm)	W (mm)	D built- in (mm)	E-MOD IN	E-MOD ON	Fig
E-VOL20	•		•	•	20W	12	80	80	32	•	•	1
E-VOL20-BL	•		•	•	20W	12	80	80	32	•	NA	2
E-VOL40	•		•		40W	12	80	80	45	•	•	1
E-VOL60	•		•		60W	12	80	80	45	•	•	1
E-VOL60-BL	•		•		60W	12	80	80	45	•	NA	2
E-VOL120	•		•		120W	12	80	80	46	NA	•	1
E-VOLST		•			2x40W @ 4Ω	10	80	80	46	NA	•	1
E-VOLST-BL		•			2x40W @ 4Ω	10	80	80	46	NA	NA	2
19-VOL660	•		•		6 x 60W	12	88	483	230	NA	NA	4
19-VOL6120	•		•		6 x 120W	12	88	483	230	NA	NA	4



Fig4



Great expectations : add that little extra touch of refined class to your home or business interior. The NIKO series of volume controls has been developed to fit the coverplates and the the timeless design, the warm character and soft lines of Belgian NIKO controllers.

CONTROL
NIKO SERIES



- Creme
- White
- Sterling
- Anthracite

Model	NIKO style	Colour	Stereo	100 Volt	Steps
N-VOLST-CO	Original	<input type="radio"/>	•		5+0
N-VOLST-WO	Original	<input type="radio"/>	•		5+0
N-VOLST-W	Intense	<input type="radio"/>	•		5+0
N-VOLST-SLV	Intense	<input type="radio"/>	•		5+0
N-VOLST-BL	Intense	<input type="radio"/>	•		5+0
N-VOL30-CO	Original	<input type="radio"/>		•	10+0
N-VOL30-WO	Original	<input type="radio"/>		•	10+0
N-VOL30-W	Intense	<input type="radio"/>		•	10+0
N-VOL30-SLV	Intense	<input type="radio"/>		•	10+0
N-VOL30-BL	Intense	<input type="radio"/>		•	10+0

•N-VOL30

- Type : NIKO volume controller
- Loudspeaker : 100 Volt mono
- Music power : 30 Watts
- Protected against overload
- 24V priority set's volume on max.
- Mounting : screw and clamp
- Cable : max. 2.5 mm²

•N-VOLST

- Type : NIKO volume controller
- Loudspeaker : stereo / 4, 8 of 16 Ω
- Music power : 2x20 Watt
- Protected against overload
- Mounting : screw and clamp
- Cable : max. 2.5 mm²



Solution

APart has all the accessories for your sound system in-house. We offer a range of four table type paging microphones and a CB-type microphone, especially designed to function plug-and-play with our electronics. APart makes the life of installers and end users a lot easier!

MICPA MICROPHONE



• MICPAT-D

- Robust table type, dynamic microphone
- Clear voice, no feedback
- Toggle switch: Talk - Off - Continuous talk
- No batteries, no power supply required
- With 3m cable and DIN5 connector



• MICPAT-2

- Robust 2-zone table type, dynamic microphone
- Push-to-talk button per zone with LED indication
- No batteries, no power supply required
- Perfect fit to APart Concept1, MA246
- With 5m cable, open wire



• MICPAT-4

- Elegant 4-zone table type directional condenser microphone
- Selection button per zone with LED-indicator
- PTT with green/red led busy indicator
- Perfect fit to APart ZONE4 pre-amplifier
- With 5 m cable and CAT5 RJ45 connector provided



• MICPAT-6

- Compact 6-zone table type directional condenser microphone
- Selection button per zone with LED-indicator
- PTT with green/red led busy indicator
- Perfect fit to APart MA246 6-zone mixing amplifier
- With 5m cable, CAT5 RJ45 connector and line cable provided



• MICPACB-D / MICPACB-X

- Sturdy CB type dynamic paging microphone
- Ideal for close talking
- On/off by pressing the non-latching switch
- DIN5 connector (D) or XLR-5 (X)
- Wall mount included

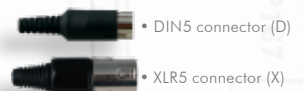

Colour

Do you want your speakers to match your interior design, disappear in the background? Or do you want to accentuate them with an extravagant colour? It's up to you ... From a minimum of 12 pieces you can have every speaker painted into the RAL colour you want. We make sure that the paint quality is just as excellent as the sound you are listening to!



PAINT CUSTOM COLOUR

- PAINTCMM
- PAINTCOL
- PAINTCM
- PAINTMP
- PAINTCAB-6
- PAINTMPLT
- PAINTCAB-8

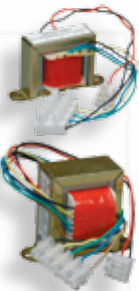

TRANSFORMERS ACCESSORIES



- T20 
 - 8Ω to 100 Volt transformer
 - 20 - 10 - 5 - 2.5 Watts power taps
- T60 
 - 8Ω to 100 Volt transformer
 - 60 - 30 - 15 - 6 Watts power taps



- T150 
 - Toroidal 4-8Ω to 100 Volt transformer
 - 150 - 120 - 90 - 60 - 30 Watts power taps

INSTALLER UTILITY ACCESSORIES



- BUZZSTOP-MKII
 - Converts any line, mic or tel signal into any line level output
 - Converts from unbalanced to balanced and vice versa
 - The audio transformer isolation avoids ground loops (Hummm)
 - Dimensions: 44 (h) x 241 (w) x 60 (d) mm



- BUZZ19
 - Metal adaptor to mount 2 pieces of BUZZ-STOPIII in a 19" rack
 - Dimensions: 43 (h) x 43 (w) mm



CABLES ACCESSORIES



- CE2E2 : euroblock2 – euroblock2
- CE3E3 : euroblock3 – euroblock3
- CE3XM : euroblock3 – XLR3 male
- CE3RY : euroblock3 – RCA cinch stereo
- CRYRY : RCA – RCA cinch stereo
- CFXFM : XLR3 female – XLR3 female
- CXFRY : XLR3 female – RCA cinch stereo

All cables are 1,5m long and supplied in plastic POS bags.

SET POINT

: Partying on the dance floor, meeting friends in a bar or enjoying a classy dinner in a restaurant? Whether it is background music in a trendy boutique or a presentation in a meeting room, quality sound is an essential part of the experience. APart offers a comprehensive range of ready-to-use sets: a combination of APart products designed to be used together!









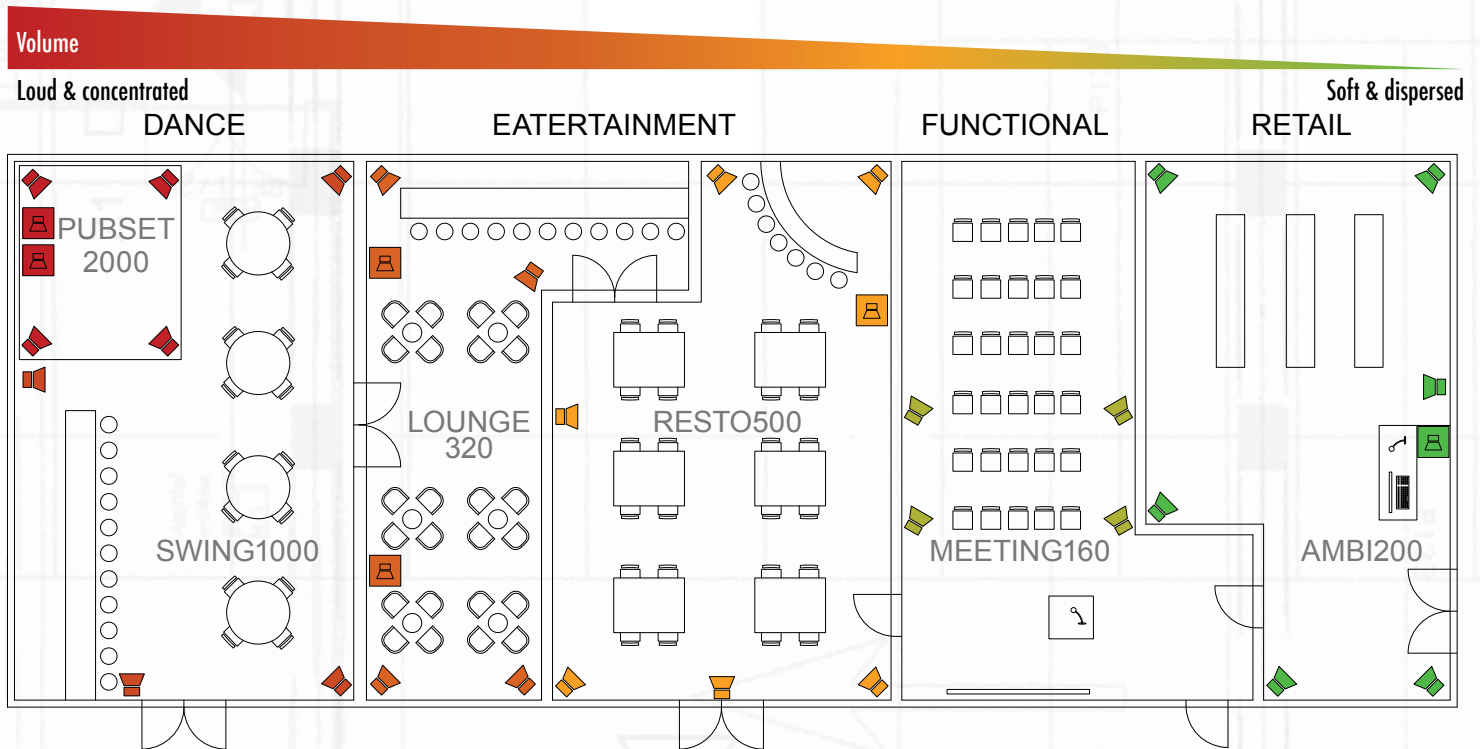

Complete coverage. Pumping beats on the dance floor, ambient level music at the bar, a relaxing atmosphere in the restaurant: finding the right combination of products is a common challenge for every installer.

The table below helps you to choose the right set for your installation. As you go from left to right in our virtual building, the sound characteristics change with every room you enter.

Loud and concentrated in the dance floor and bar area, background level in the restaurant, speech amplification in the meeting room, soft and dispersed sound in the retail area. The colour code on the dial indicates which set to use for which application.

APart offers a comprehensive range of ready-to-use sets, a combination of products designed to be used together. Let our expertise help you to take the hassle out of system design!



-  PUBSET-2000 Page : 75
-  SWING1000 Page : 75
-  LOUNGE320 Page : 76
-  RESTO500 Page : 76
-  MEETING160 Page : 77
-  AMBI200 Page : 77

Details of the specified products can be found elsewhere in this catalogue : please consult the following pages of this chapter or the index at the back of the catalogue.



Finally your search for a custom designed audio system for use in bars and pubs can come to an end: these systems are designed for 24/7 worry free operation in the most demanding environments! PUBSET-2000 brings dance level music with a deep powerful kick bass that makes you stop in your tracks and wonder... while SWING1000 offers ambiance level music that the audience can enjoy in all its details.

SWING1000 FOUNDATIONS



Especially for use in: areas surrounding the dance floor, music bars, cafés, pubs, sport bars
For venues where music is a key element, from ambiance to party level

Consists of: 1 x Champ-One amplifier + 4 x MASK8F full range speakers. 1200 Watts music power.

- SWING1000-BL: black fronted amplifier and black speakers
- SWING1000-W: silver fronted amplifier and white speakers

PUBSET-2000 DANCE



Especially for use in: dance floor area, dance café, music bar, fitness clubs
For venues where you not only want to hear, but feel the music!

Consists of: 4 x MASK8 top speakers + 2 x SUB2400 subwoofers + 1 x PUBDRIVE2000 amplifier
2000 Watts music power.

- PUBSET-2000-BL: with black top speakers and subwoofers
- PUBSET-2000-W: with white top speakers and subwoofers

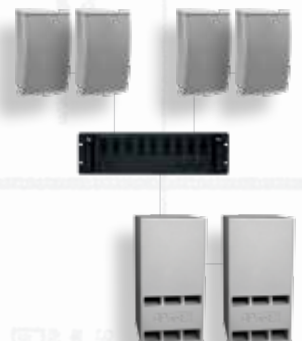



Eatertainment

With the sets on this page, APart introduces two complete and ready-to-use sound systems, especially designed for use in lounge bars, restaurants, tearooms and function rooms. They take care of background and atmosphere music, but still have enough headroom to reproduce a speech or the occasional "happy birthday, happy new year" party atmosphere. APart sets bring atmosphere to any outing!

LOUNGE320 LOUNGE



Especially for use in: Lounge bars, bistros, private rooms...

A combination of four design top speakers, two ultra-flat subwoofers that can be hidden behind a curtain or underneath a wardrobe, and a silent, convection cooled power amplifier. Especially for use in lounge bars, bistros, function rooms.

500 Watts music power.

- 1 x Champ-4 amplifier
- 4 x MASK4 cabinet speakers
- 2 x SUBTILE subwoofer

- LOUNGE320-BL : black speakers & black subwoofers
- LOUNGE320-W: white speakers & white subwoofers
- LOUNGE320-SLV : silver speakers & white subwoofers

RESTO500 BACKGROUND MUSIC



Especially for use in: restaurants, bistros, function rooms...

A combination of six design top speakers, a silent, convection cooled power amplifier and a strong subwoofer. This set guarantees full, discrete and evenly spread musical sound for all those venues where music is an essential part of the atmosphere.

700 Watts music power.

- 1 x Champ-2 amplifier
- 6 x MASK4 cabinet speakers
- 1 x SUB2200 subwoofer

- RESTO500-BL : black top speakers
- RESTO500-W: white top speakers
- RESTO500-SLV : silver top speakers



Small business

system: These sets have all the requirements of small businesses in mind! AMBI200 provides background music and paging in retail environments. MEETING 160 is specially designed for presentations in meeting rooms.

AMBI200 RETAIL



Thanks to the very small top speakers that are easy to hide to place discretely, this set is especially recommended for use in retail areas: gas station shop, hair stylist, boutique, travel agency, minimart, art gallery,...

For venues that need a 24/7 reliable system for background music, with paging possibilities.

- 6 x SDQ3T top speakers
- 1 x CONCEPT1 integrated amplifier
- 1 x SUBA165 active subwoofer

- AMBI200-BL : with black speakers & black subwoofer
- AMBI200-W : with white speakers & white subwoofer
- AMBI200-SLV : with silver speakers & white subwoofer

MEETING160 MEETING



For use in meeting rooms, boardrooms, small places of worship,...

For venues that need a professional system for audio playback and very clear voice reproduction.

- 1 x CONCEPT1 integrated amplifier
- 4 x MASK6 speakers
- 2 x MASKL fixation brackets sets

- MEETING160-BL : with black top speakers
- MEETING160-W : with white top speakers

APart

INDEX TABLE

PRODUCT	PAGE	PRODUCT	PAGE	PRODUCT	PAGE	PRODUCT	PAGE
19-VOL6120	70	CMX20T-SLV	13	MASKL-BL	23	PT8120	48
19-VOL660	70	COLS101	35	MASKL-W	23	PUBDRIVE-2000	49
AMBI120-BL	19	COLS141	35	MASKV-BL	23	PUBSET-2000-BL	77
AMBI120-W	19	COLS41	35	MASKV-W	23	PUBSET-2000-W	77
AMBI200-BL	79	COLS81	35	MASKW-BL	23	PXQ2215	43
AMBI200-SLV	79	COLSBRA	35	MASKW-W	23	QUADPACK	67
AMBI200-W	79	COLW101	34	MB150	64	RESTO500-BL	78
AUDIOLOCK	43	COLW41	34	MB19	67	RESTO500-SLV	78
BB1	39	COLW81	34	MBAC	67	RESTO500-W	78
BB2	39	COLWBRA	34	MBBL	67	RJ45-SPLIT	41
BBi1	39	CONCEPT1	50	MBR150	65	ROCK20	31
BBi2	39	CONCEPT1-RC	51	MEETING160-BL	79	ROCK608	31
BUZZ19	73	CONCEPT1-TKIT	51	MEETING160-W	79	SAFCAB6	23
BUZZSTOP-MKIII	73	CONCEPT1T	50	MEQ5.2	66	SB160	64
CE2E2	73	CRYRY	73	MICPACB-D	72	SBR160	65
CE3E3	73	CXFRY	73	MICPACB-X	72	SDQ3T-BL	28
CE3RY	73	CXFXM	73	MICPAT-2	72	SDQ3T-SLV	28
CE3XM	73	DT-150	66	MICPAT-D	72	SDQ3T-W	28
CHAMP-2	46	E-MOD-IN	70	MICPAT4	72	SDQ5-BL	28
CHAMP-4	47	E-MOD-ON	70	MICPAT6	72	SDQ5-W	28
CHAMP-ONE	44	E-VOL120	70	MP16-G	32	SDQ5P-BL	27
CHAMP-ONE SLV	44	E-VOL20	70	MP26-G	32	SDQ5P-W	27
CM1008	13	E-VOL20-BL	70	MPH30-G	32	SDQ5PIR	27
CM20T	11	E-VOL40	70	MPLT32-G	33	SDQ5T-BL	28
CM20T-BL	11	E-VOL60	70	MPLT62-G	33	SDQ5T-SLV	28
CM20T-SLV	11	E-VOL60-BL	70	N-VOL30-BL	71	SDQ5T-W	28
CM3T	9	E-VOLST	70	N-VOL30-CO	71	SDQ8-BL	29
CM3T-BL	9	E-VOLST-BL	70	N-VOL30-SLV	71	SDQ8-W	29
CM3T-SLV	9	EIGHTPACK	49	N-VOL30-W	71	SDQ8T-BL	29
CM4T	9	H10-G	33	N-VOL30-WO	71	SDQ8T-W	29
CM4T-BL	9	H20-G	33	N-VOLST-BL	71	SIXPACK	67
CM4T-SLV	9	H30LT-G	33	N-VOLST-CO	71	SLAC	67
CM5E	10	INTELLI-MOUNT	23	N-VOLST-SLV	71	SPH16	31
CM608	11	LOCK-KEY	41	N-VOLST-W	71	SPH20	31
CM608-BL	11	LOUNGE320-BL	78	N-VOLST-WO	71	STFLOOR	25
CM608-SLV	11	LOUNGE320-SLV	78	NTM-1	38	STSUB	25
CM6E	10	LOUNGE320-W	78	PA-CONF	62	STT	25
CM6E-BL	10	MA125	53	PA-CONF-SET	63	SUB2200	25
CM6E-SLV	10	MA200	54	PA-CONF-C	62	SUB2201-BL	25
CM6QFT	12	MA200CDR	54	PA-CONF-D	62	SUB2201-W	25
CM6SF	9	MA200R	54	PA-CONF-DI	62	SUB2400	25
CM6T	11	MA246	56	PA2240BP	59	SUB2400-W	25
CMBB	11	MA246MR	56	PA240P	58	SUBA165	26
CMR15T	17	MA246R	56	PA8250	48	SUBA165-W	26
CMR20T	17	MA35	53	PAM7.2	66	SUBLIME-BL	19
CMR4BBI	17	MA35-19	53	PC1000R	60	SUBLIME-W	19
CMR5	17	MA65	53	PCD-REM	60	SUBTILE-BL	26
CMR608	17	MASK2-BL	19	PCR3000R	60	SUBTILE-W	26
CMRBB	17	MASK2-W	19	PIR-EMIT	42	SWING1000-BL	77
CMRBBi	17	MASK4-BL	21	PIR-REC	42	SWING1000-W	77
CMRQ108	15	MASK4-SLV	21	PIR-REM	42	T150	73
CMRQ108BBI	15	MASK4-W	21	PIR7600	42	T20	73
CMRQ108C	15	MASK4T-BL	21	PM1122	38	T60	73
CMRQ108CBBI	15	MASK4T-SLV	21	PM1122-INT	39	ZONE4	40
CMS15T	16	MASK4T-W	21	PM1122R	39	ZONE4R	40
CMS20T	16	MASK6-BL	22	PM1122RL	39		
CMS508	16	MASK6-W	22	PM1122W-BL	38		
CMS5BBI	16	MASK6T-BL	22	PM1122W-SLV	38		
CMS608	16	MASK6T-W	22	PM1122W-W	38		
CMS6BBI	16	MASK8-BL	24	PM1122WR	39		
CMSUB8	13	MASK8-W	24	PM7400MKII	42		
CMX20T	13	MASK8F-BL	24	PR1000R	61		
CMX20T-BL	13	MASK8F-W	24	PR4000R	61		