

Computer Audio Interfaces

FIREPOWER FCA1616/FCA610



Audiophile Multi-I/O, 24-Bit/96 kHz USB/FireWire Audio/MIDI Interfaces

FCA1616 — Audiophile 16 In/16 Out, 24-Bit/96 kHz USB/FireWire Audio/MIDI Interface with ADAT

- Streams 16 inputs/16 outputs plus 1x MIDI I/O with ultra-low latency to your computer, supporting Mac OS X and Windows XP or higher
- 4 state-of-the-art, phantom-powered XENYX Mic Preamps comparable to stand-alone boutique preamps with individual Pad, Low Cut and Hi-Z
- All standard I/O formats supported – analog, S/PDIF (coaxial and optical), ADAT, S/MUX
- Get 8 additional microphone inputs and line outputs with the BEHRINGER ADA8000 (not included) - connected via ADAT
- 8 analog Inserts for use of external effects such as compressors, etc.
- Powered via external power supply (included)
- Standard 19"/1U rack-space form factor

FCA610 — Audiophile 6 In/ 10 Out, 24-Bit/96 kHz USB/ FireWire Audio/MIDI Interface

- Streams 6 inputs / 10 outputs plus 1x MIDI I/O with ultra-low latency to your computer, supporting Mac OS X and Windows XP or higher
- 2 state-of-the-art, phantom-powered XENYX Mic Preamps comparable to stand-alone boutique preamps with individual Pad, Low Cut and Hi-Z
- Ultra-flexible connectivity via analog and S/PDIF I/O ports (coaxial and optical)

behringer.com

Market

Musicians, podcasters, professional and home recording studios, recording engineers, audio rental companies

Applications

Computer-based recording audio/MIDI interface and A/D-D/A converter

Availability

TBA

Predecessor

None

Key Selling Points

USB/FireWire connectivity, 24-Bit/96 kHz A/D-D/A converters, XENYX mic preamps, 2 powerful phones outputs with individual Volume controls, FCA610's small form-factor makes it ideal for musicians on the road, FCA1616 can be used in conjunction with BEHRINGER ADA8000 for 8 additional mic inputs and line outputs, massive free software download available at behringer.com

Competition

FCA1616: Mackie Blackbird, MOTU pre8
FCA610: Focusrite Scarlett Series, M-Audio ProFire 610

FIREPOWER AUDIO USB/FireWire audio interfaces are the ideal way to stream audio to and from your PC or Mac computer. These handy interfaces feature state-of-the-art XENYX mic preamps, legendary the world over for their pristine clarity and high-headroom sonic performance, plus our 24-Bit/96 kHz A/D-D/A converters will really respect your input. Both interfaces support Windows XP/Vista/7 plus Mac OS X and provide onboard phantom power for use with studio-grade condenser microphones. Hook up to the BEHRINGER FCA Series and instantly turn your computer into a powerful recording/editing workstation.

Your Portal to the Digital Domain

The FCA Series allows you to converse with your computer in a language it understands... digital. When you connect line-level devices, such as synthesizers or the outputs of an audio mixer to an FCA1616 or FCA610, internal 24-bit A/D

(Analog to Digital) converters swing into action, turning the audio signal into digital data. Now you can record and play back your masterpiece through a pair of active studio monitors or listen in the privacy of your favorite headphones.

FCA1616

With its expanded 16 channel I/O, 4 XENYX mic preamps and ADA8000 ADAT connectivity, the FCA1616 is ideal for more permanent applications, such as home and professional recording studios, as well as live performance multi-track recording rigs. All standard I/O formats are supported including analog, S/PDIF (coaxial and optical), ADAT and S/MUX. Built-in MIDI I/O allows you to connect keyboards and other outboard MIDI hardware. The single rack-space FCA1616 also features 8 analog Inserts for use of external effects such as compressors, gates and EQs, etc. A dedicated power supply is included.

Continued on next page



FIREPOWER FCA1616/FCA610

- Powered via external power supply (included) or 6-pin FireWire bus
- Compact 9.5" half-rack-space form factor

Common Features

- Audiophile ultra low-noise, high headroom audio interface with 24-Bit/96 kHz resolution
- Multi-channel audio and MIDI operation via FireWire 400 or USB2.0
- Direct Monitoring and Main Volume control on hardware front – no confusing software mixer panel
- 2 powerful Headphone outputs with individual Volume control, Mono and Source signal select
- Level control of your stereo or 7.1 active speaker system with a single knob turn
- Smooth cross-fading between inputs and DAW playback signals while you record sessions
- Status and signal presence indication for all analog and digital I/O
- Free audio recording, editing and podcasting software plus 150 instrument/effect plug-ins downloadable at behringer.com
- Standard port for Kensington security lock provided
- High-quality components and exceptionally rugged construction ensure long life
- Conceived and designed by BEHRINGER Germany

FCA610

Due to its small size and low-latency operation, 6 In / 10 Out architecture, plus 2 highly-acclaimed XENYX mic preamps, the FCA610 is a dream come true for traveling musicians who record and edit on their laptops. The portable FCA610 can receive power from your computer's 6-pin FireWire bus or via the included external power supply. Built-in MIDI I/O allows you to connect keyboards and other outboard MIDI hardware. All standard I/O formats are supported including analog and S/PDIF (both coaxial and optical). The half-rack-space FCA610 stows easily in your travel kit.

Getting Connected

On the rear panels of the FCA1616 and FCA610, you'll find ports for FireWire and USB 2.0. Inputs are balanced ¼" jacks that accept a wide range of line-level devices. Outputs accept both balanced and unbalanced ¼" connections. The two headphones jacks are conveniently located on the front panel, with a dedicated volume control.

The Technical Stuff

Both FIREPOWER FCA1616 and FCA610 interfaces feature state-of-the-art, high-resolution 24-bit A/D-D/A

converters, supporting up to a 96 kHz sampling rate. Reliable Windows XP, Windows Vista, Windows 7 drivers and Mac OS X support ensure ultra-low latency operation.

How About Some Free Software!

Because you'll want to take full advantage of your computer's recording, editing and podcasting potential, we've put together a massive software download at behringer.com that includes Audacity (the most popular open source audio editor), Podifier, Juice, Podnova and Golden Ear (a great selection of podcasting software). You're ready to go live on your PC or Mac right out of the box! You also get more than 100 virtual instruments and 50 FX plug-ins, turning your computer into a complete home-based or mobile recording studio.

Sound Value

Stop by your authorized BEHRINGER dealer today and join the digital revolution. With our super-affordable FIREPOWER FCA Series FireWire/USB audio interfaces, you'll get blazing-fast streaming to and from your computer, plus our amazingly sweet XENYX mic preamps, and much more—and we cover you with a comprehensive warranty program.

FCA1616 Front Panel

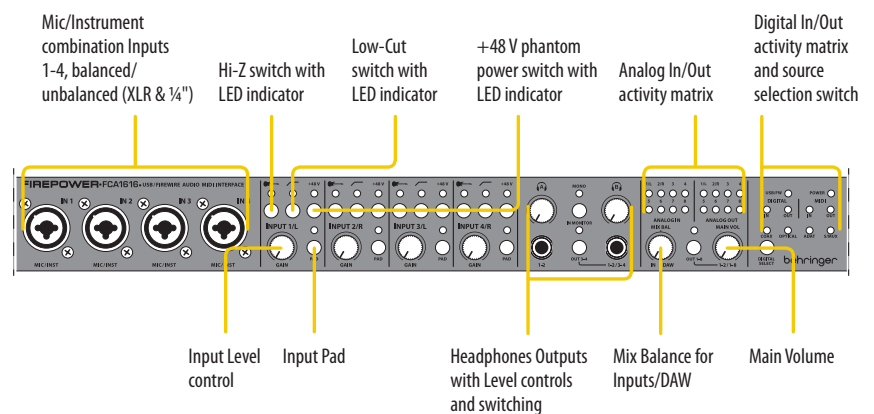

FIREPOWER FCA1616/FCA610

FCA1616 Rear Panel

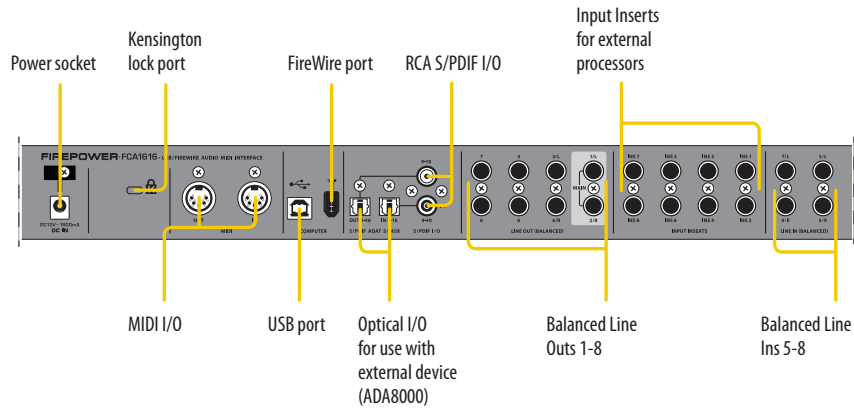

FCA610 Front Panel

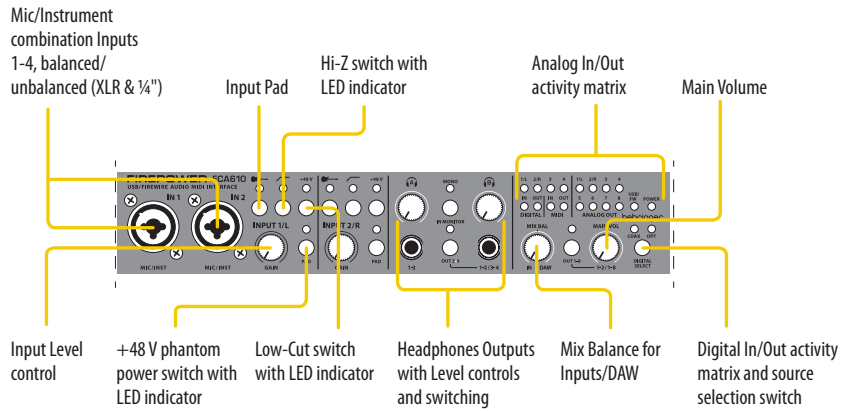

FCA610 Rear Panel

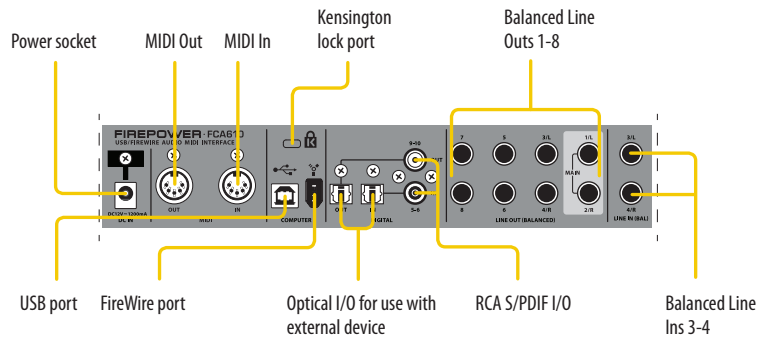

FIREPOWER FCA1616/FCA610

FCA1616 Home Recording Studio

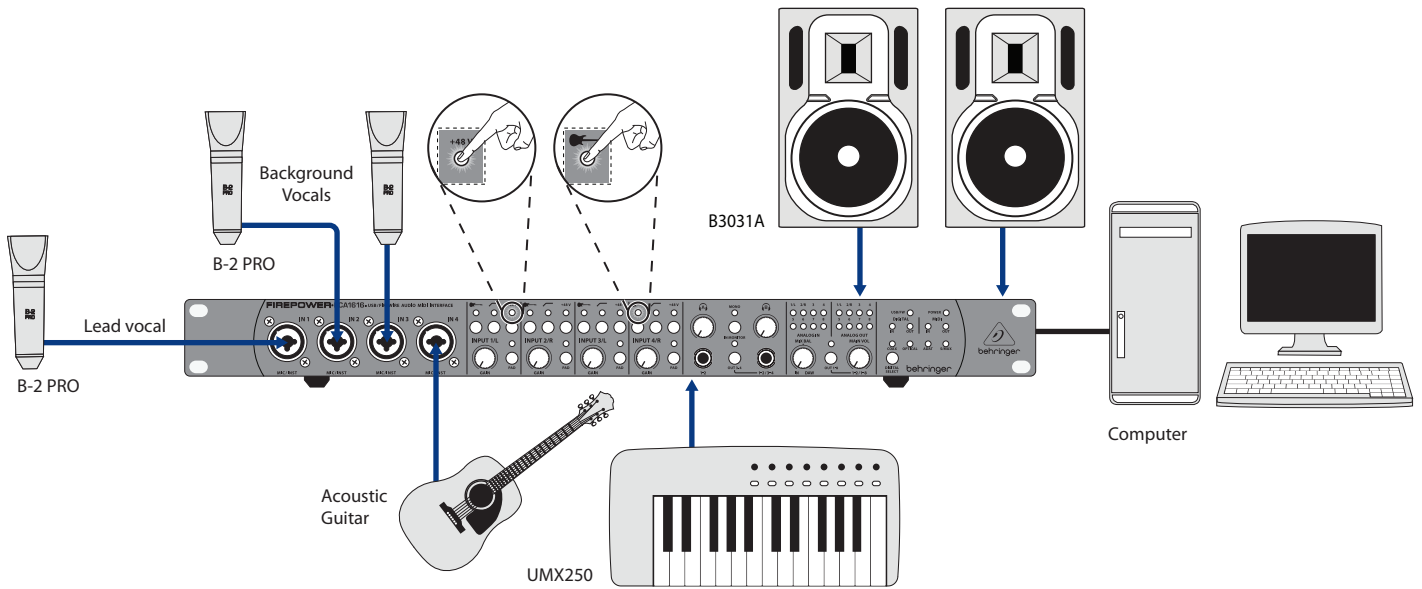

FCA610 "On-the-Road" Recording Studio

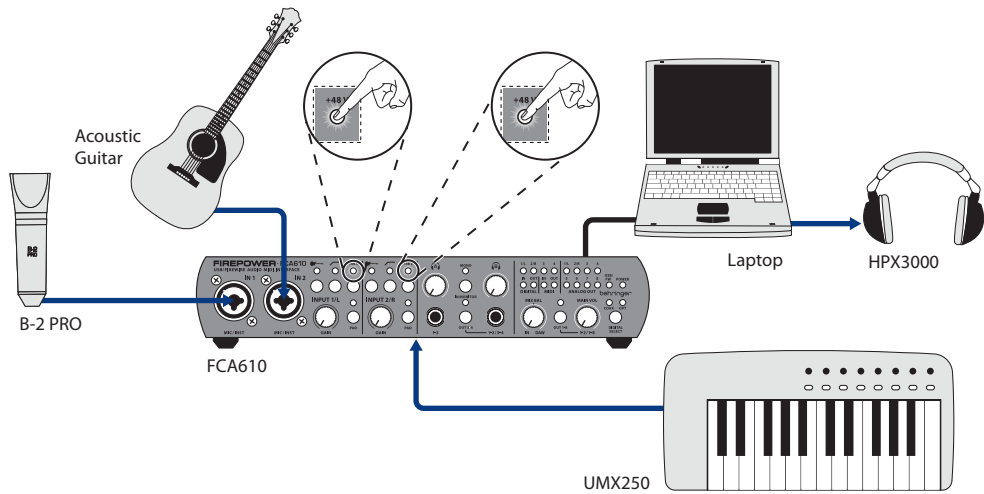

FIREPOWER FCA1616/FCA610

FCA610 Podcast Setup

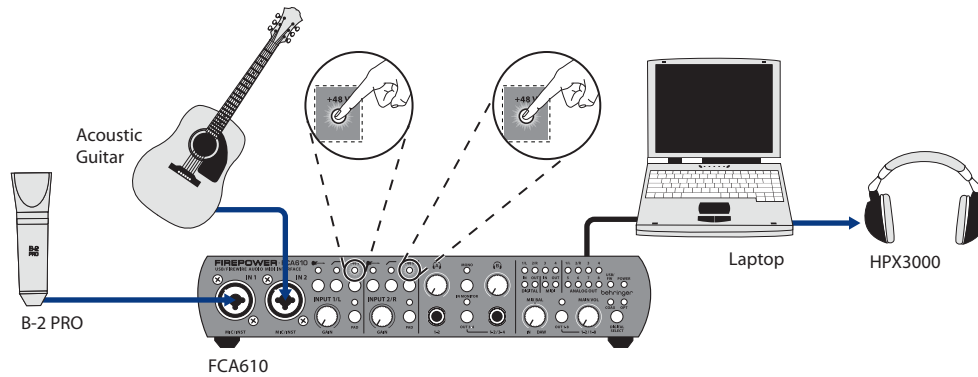

Feature	FCA1616	FCA610
Total I/O channels	16 x 16	6 x 10
Analog I/O channels	8 x 8	4 x 8
Mic Preamps	4	2
Input Channel Selections with LED control	Ch. 1-4: Each Hi-Z, Low Cut, +48 V, Pad	Ch. 1-2: Each Hi-Z, Low Cut, +48 V, Pad
Input Inserts	8	0
Digital I/O connectors	Coaxial-I/O (RCA) + Optical-I/O (TOS-Link)	Coaxial-I/O (RCA) + Optical-I/O (TOS-Link)
Digital I/O formats	S/PDIF I/O (2-channel), S/MUX I/O (4-channel), ADAT I/O (8-channel)	S/PDIF I/O (2-channel)
Digital Select (front panel)	Coaxial, Optical, ADAT, S/MUX	Coaxial, Optical
Phones Outputs	2 x 1/4" jacks with individual level control Monitoring Phones A: Out 1-2 Monitoring Phones B: Out 1-2 / Out 3-4	
Direct Monitoring	Mix Balance knob: Smooth crossfading between direct input and DAW playback signal Mono switch: for direct input signal	
Main Volume Control	Level Control of Line Out 1-2 or 1-8 simultaneously with a single knob turn	
MIDI I/O	1 x I/O	
Metering	Analog In 1-8: Dual color LEDs (Signal/Clip) Analog Out 1-8: Dual color LEDs (Signal/Clip)	Analog In 1-4: Dual color LEDs (Signal/Clip) Analog Out 1-8: Dual color LEDs (Signal/Clip)
Additional Status LEDs	Digital I/O, MIDI I/O, USB/FireWire (dual color), Power	Digital I/O, MIDI I/O, USB/FireWire (dual color), Power
USB/FireWire Interface	16 x 16 I/O channels, up to 24-bit/96 kHz	6 x 10 I/O channels, up to 24-bit/96 kHz
Bus-powering	Only via 6-pin FireWire (if computer feeds enough power)	
Power Supply	External Power Supply (included)	
Form factor	Approx. 19" / 1U	Approx. 9.5" / 1U
19" rack mount brackets	Removable	N/A

Contact the BEHRINGER location nearest you:

Europe MUSIC Group Services EU GmbH
Tel.: +49 2154 9206 4149

Singapore MUSIC Group Services SG (Pte.) Ltd
Tel.: +65 6845 1800

Japan MUSIC Group Services JP K.K.
Tel.: +81 3 5281 1180

USA/Canada MUSIC Group Services US Inc.
Tel.: +1 425 672 0816

Australia MUSIC Group Services AU Pty Ltd
Tel.: +61 03 9877 7170

This device has not been authorized by the rules of the Federal Communications Commission. This device is not, and may not be, offered for sale or lease, or sold or leased in the 50 U.S. states, the District of Columbia and U.S. possessions, until authorization is obtained. Technical specifications and appearances are subject to change without notice and accuracy is not guaranteed. BEHRINGER is part of the MUSIC Group (music-group.com). All trademarks are the property of their respective owners. MUSIC Group accepts no liability for any loss which may be suffered by any person who relies either wholly or in part upon any description, photograph or statement contained herein. Colors and specifications may vary from actual product. MUSIC Group products are sold through authorized fulfillers and resellers only. Fulfillers and resellers are not agents of MUSIC Group and have absolutely no authority to bind MUSIC Group by any express or implied undertaking or representation. This manual is copyrighted. No part of this manual may be reproduced or transmitted in any form or by any means, electronic or mechanical, including photocopying and recording of any kind, for any purpose, without the express written permission of MUSIC Group IP Ltd. ALL RIGHTS RESERVED. © 2012 MUSIC Group IP Ltd. Trident Chambers, Wickhams Cay, P.O. Box 146, Road Town, Tortola, British Virgin Islands. FOR INTERNAL USE BY BEHRINGER DEALERS ONLY. DO NOT DISTRIBUTE.